

- **NE3627HSV** 35-3/4"L x 33"D x 27-7/8"H
- **NE4827HSV** 47-3/4"L x 33"D x 27-7/8"H

Included

- NOTE: Glass warranty only applicable to first point of delivery
- Convection heat
- (2) Levels of clear glass shelving removable and adjustable on 1" centers
- Glass end
- LED top & shelf lights
- NOTE: Overall case height is 47-1/8" (includes below counter)
- One year parts & labor warranty
- Stainless steel interior
- UV bonded frameless glass
- Vertical swing out front glass



NE3620HSV

Specify	Standard Features	Additional Options
FRAME EXTERIOR COLOR	<ul style="list-style-type: none"> • Powder coated Silversan Black 	<ul style="list-style-type: none"> • Powder coated (stock/non-stock colors) • Stainless steel
BASE	<ul style="list-style-type: none"> • Slide in counter assembly 	
REAR DOORS	<ul style="list-style-type: none"> • Clear glass rear sliding doors 	<ul style="list-style-type: none"> • Reflective glass rear sliding doors
LIGHTS	<ul style="list-style-type: none"> • LED 3500K w/ frosted lens 	<ul style="list-style-type: none"> • LED 3000K w/ frosted lens • LED 4000K w/ frosted lens
ELECTRICAL CONNECTION	<ul style="list-style-type: none"> • 10' Straight blade power cord 	<ul style="list-style-type: none"> • 10' Locking blade power cord • Electrical leads (non-refrigerated)
MISCELLANEOUS		<ul style="list-style-type: none"> • Humidification system • Remoted control (allows controls to be up to 8' from center of case) • Second year parts & labor warranty

Intended Environment: Type I - Designed to operate in ambient conditions of 75°F with 55% relative humidity unless noted otherwise in system information below.		
Zone	Intended Product To Be Displayed	Warmest Avg Prod Temp ° F
1	Packaged / unpackaged heated products	160

PLAN VIEW

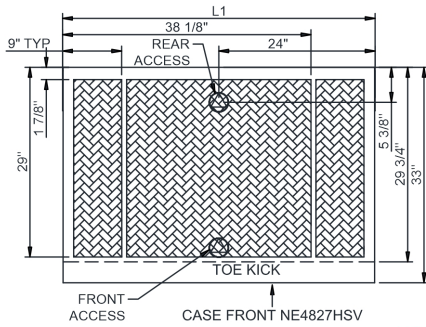
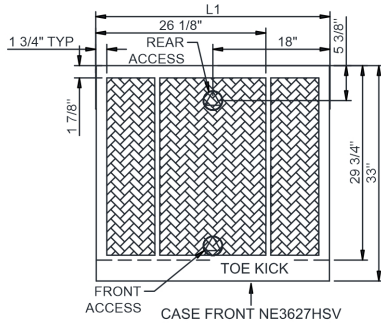

SIDE VIEW

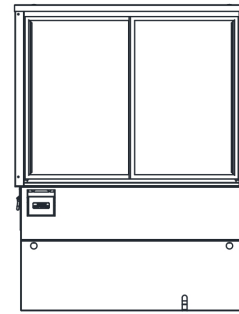
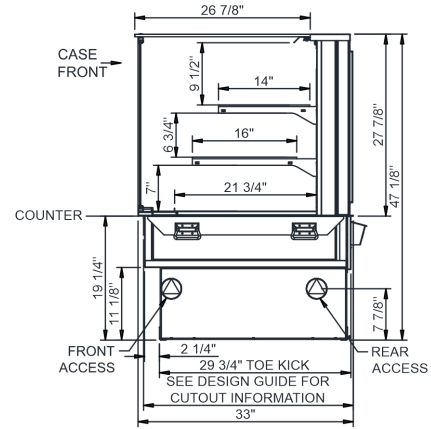

NOTE: ALL DIMENSIONS APPROXIMATE

- ELECTRICAL JUNCTION BOX (SUPPLIED WITH 6\"/>**
- LOCATION OF DRAIN TUBE FOR REMOTE REF. ONLY (SUPPLIED WITH 3/4\"/>**

- REFRIGERATION LINE CONNECTION.**
- REMOTE FLOOR SINK & UTILITIES ACCESS AREA.**

- SELF-CONTAINED CASE SERVICE ACCESS AREA.**
- DRY CASE SERVICE ACCESS AREA.**

Model Technical Specifications																	
Model	L"	L1"	L2"	System Circuit Volts			Phs	Freq	Amps ***	Watts	Wires	NEMA Plug	SST	Conv. Rack BTUH	Para. Rack BTUH	Est Wt	
NE3627HSV	N/A	35.75	.00	Heat (N/A)			Circuit #1	208-240	1	60	14.25	2,806	2+G	6-20P or L6-20P	N/A	N/A	700
NE4827HSV	N/A	47.75	.00	Heat (N/A)			Circuit #1	208-240	1	60	19.94	3,957	2+G	6-30P or L6-30P	N/A	N/A	850

*** Does not include electric defrost on freezer models.

Regulatory Approvals:	
All Models	ETL Listed to UL 197 ETL Listed to CAN/CSA 22.2 No. 109 ETL Sanitation to NSF/ANSI 4



Important Notes:

- 1) ELECTRICAL NOTE: If GFCI is required, a GFCI breaker MUST be used in lieu of a GFCI receptacle.
- 2) 19.25" minimum space required beneath counter surface.
- 3) Glass warranty only applicable to first point of delivery.

⚠ WARNING: This product can expose you to chemicals, including Urethane (Ethyl Carbamate), which are known to the State of California to cause cancer and birth defects or other reproductive harm. For more information go to www.P65Warnings.ca.gov.