



ATLAS METAL

1135 N.W. 159th DRIVE, MIAMI, FLORIDA 33169

TEL 305.625.2451

TOLL FREE 800.762.7565

FAX 305.623.0475

WWW.ATLASFOODSERV.COM

SALES@ATLASFOODSERV.COM

Project: _____

Item No.: _____

Quantity: _____

MODULAR UNITS CA SERIES



CAFB-4 SHOWN WITH ACCESSORIES

COLD FOOD UNIT

Refrigerated Frost Top with Refrigerated Base

CAFB-4

CAFB-5

SPECIFICATIONS

TOP: Constructed of 16 gauge, type 304 stainless steel, die-formed, welded, ground and polished. The top is provided with an opening to receive the appropriately sized drop-in unit. An integral locking device shall be provided to align and retain cart positioning when two or more carts are joined.

BODY: Frame construction shall be of hi-tensile aluminum square tubing, 1-1/4" x 1-1/4". Frame sections are welded construction, ground and polished to a uniform finish. Body is complete with front panel and (2) end panels of plastic laminate on .063 aluminum. Owner to specify finish.

REFRIGERATED FROST TOP: The cart includes a WF series drop-in refrigerated frost top installed in the top. Constructed of 18 gauge, type 304 stainless steel, with a raised perimeter bead and solid vinyl gasket. The frost top (plate) is 14 gauge stainless steel with copper tubing firmly soldered to the exterior bottom. The unit is fully insulated with high density fiberglass and polystyrene, 1-1/2" thick, and enclosed with an 18 gauge galvanized steel outer case. The top stands 1" above the counter top and is surrounded by a 1/2" full perimeter gutter to collect melted condensate. A 1" IPS drain is provided.

REFRIGERATED BASE: RB Series: Double wall constructed with a 20 gauge, type 304 stainless steel interior liner, with coved corners. Cart body forms the exterior of the base with an 18 gauge stainless steel fascia on operator's side. The unit is insulated with 1" of high density polystyrene on all sides. The interior is provided with a slide assembly to accommodate 12" x 20" pans. A 2-1/2" dial thermometer is mounted in the fascia. Doors are double wall constructed of 18 gauge, type 304 stainless steel, fully insulated with high density polyurethane and provided with edge mounted, chrome plated hinges and a slam action latch. Doors are complete with a moisture-proof gasket.

REFRIGERATION SYSTEM: Two (2 ea.) fully self-contained condensing units are provided, one integral with the frost top, the other integral with the refrigerated base, each with a hermetically sealed compressor and a thermostat control. The refrigerated base is also provided with a forced air evaporator which drains into a condensate evaporator. The systems are fully charged and ready to operate. Two (2 ea.) removable louvered access panels are provided.

ELECTRICAL: The unit will be wired for 15 amps., 120 volt, single phase operation with an on/off thermostat switch and pilot light. A 6' long, 3-wire cord and plug (NEMA 5-15P) will be provided.

CASTERS: The casters shall be 5" diameter, non-marking rubber tired, swivel type with ball bearings in both swivel and axle raceways, provided with grease fittings. Both casters on operator's side have toe activated brakes.

Specifications subject to change without notice.

STANDARD FEATURES

- "Quick," frost top, stands 1" above counter for attractive display - ideal for pre-plated foods
- Refrigerated base for backup storage
- Fully insulated for maximum efficiency and energy savings
- Self-contained refrigeration system - just plug it in and turn it on
- Positive self-locking device - keeps tops level and equipment in place
- Fully mobile - each unit is provided with 5" dia. swivel casters, two with brakes
- Versatile - available in a wide range of sizes and a wide variety of finishes and colors
- 1-Year Parts & Labor Warranty
- UL Listed & NSF Approved

ACCESSORIES

- **SL** - Tray Slide, 11-1/4" wide, S/S, 2-rail, fold-down
- **SLT** - Tray Slide, 11-1/4" wide, S/S, 3-rail, fold-down
- **SLS** - Tray Slide, 11-1/4" wide, S/S solid, ribbed, fold-down
- **SLF** - Tray Slide, 11-1/4" wide, plastic laminate with S/S runners, fold-down
- **SH** - Work Shelf, 8" wide, S/S, fold-down
- **CB** - Work Shelf, 8" wide, hardwood maple, fold-down
- **CR** - Work Shelf, 8" wide, Richlite, fold-down
- **ES** - End Shelf, 16" wide, S/S, fold-down
- **CBE** - End Shelf, 16" wide, hardwood maple, fold-down
- **S** - S/S Front Panel
- **EPS** - S/S End Panel (each)
- **PP** - Painted Panels, urethane, in lieu of laminate
- **Sneeze Guards** - various styles available (see sneeze guard section of catalog)
- **JBC** - Outlet Box in base, 4x4 (120V) with cord
- **ERS** - Electrical Raceway System
- **PCS** - 7 to 10 ft. Power Cord
- **CW** - Cord Wrap
- **P-CAST** - Polyurethane Casters, 2-W/Brakes
- **Legs** with adjustable feet in lieu of casters
- **BSF** - Front Skirt with recessed casters
- **BSE** - End Skirt (each)
- **BSR** - Rear Skirt
- **5YW** - 5-Year Compressor Warranty (2 Required)
- **WFFT** - Flush top for frost top units
- 18" x 26" Pan Rack, 3-1/2" O.C. (7 ea.)(available on CAFB-4 only)
- *220 Volt - 50 Cycle Compressor

* Units with these accessories are not currently UL listed.

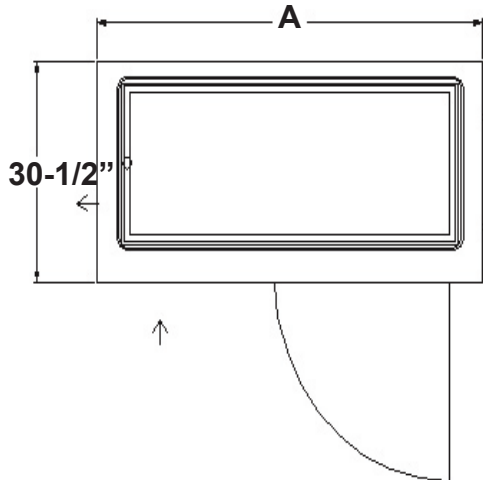

PLAN VIEW

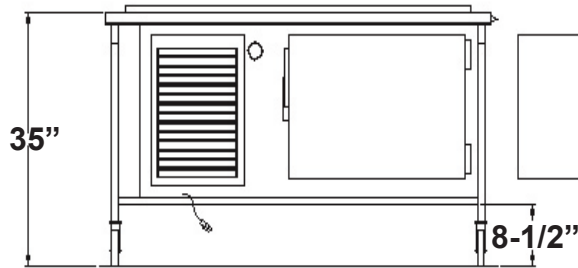

REAR ELEVATION

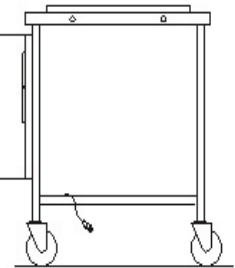

END VIEW

MODEL	"A"	FROST TOP SIZE	REFRIGERATED BASE CAPACITY - 12" X 20" PANS	ELECTRICAL CHARACTERISTICS	SHIP WT. (lbs.)
CAFB-4	63-3/4" (161.9cm)	19-1/2" X 52-3/4" (49.5 X 133.9cm)	10 Pans - 1 Door - 8 cu. ft.	13.4 amps. - 120 V - 1/3 HP & 1/4 HP	610 (276.6kg)
CAFB-5	77-1/2" (196.8cm)	19-1/2" X 66-1/2" (49.5 X 168.9cm)	15 Pans - 2 Doors - 10 cu. ft.	17.9 amps. - 120 V - 1/2 HP & 1/4 HP	705 (319.7kg)