

"ST6R5-GSK" STAINLESS STEEL TOP WORK TABLES

16GA Top w/5" Riser & Galvanized Legs & Adjustable Undershef

FEATURES:

- 16GA Stainless Steel Top w/5" Riser & Turndown
- Type 300 Stainless Steel With #4 Polish, Satin Finish
- Top Is Sound Deadened
- Reinforced With 1"x2" Channel Running Entire Length Of Table
- 1-1/2" Stallion Edge On Front Side Edges 90 Degree Bend Down For Table Line-Up
- Galvanized Base With Adjustable Undershef
- Ships Knocked-Down Easy-To-Assemble

SPECIFICATIONS:

- Top: Stainless Steel Tops Are TIG Welded, Exposed Welds Are Polished To Match Adjacent Surface
- Top: 16GA Stainless Steel Type 300 Stainless Steel With #4 Polish, Satin Finish
- Shelf: 18GA Galvanized Steel, (36" Wide Tables, 16GA Lower Shelf)
- Legs: 1-5/8" Round O.D. 16GA Tubular Galvanized Steel
- Gussets: Galvanized Steel
- Feet: 1" Adjustable Stainless Steel Bullet Feet



ST6R5-3048GSK

CERTIFICATIONS:



ACCESSORIES

DESCRIPTION
Drawer
Drawer Lock
Casters
Overshelves
Sinks
Pot Rack

"ST6R5-GSK" STAINLESS STEEL TOP WORK TABLES

LENGTH	24" WIDE	WT	WT CAP	30" WIDE	WT	WT CAP	36" WIDE	WT	WT CAP
24"	ST6R5-2424GSK	44	900	ST6R5-3024GSK	49	900	ST6R5-3624GSK	58	900
30"	ST6R5-2430GSK	49	900	ST6R5-3030GSK	54	900	ST6R5-3630GSK	68	900
36"	ST6R5-2436GSK	55	900	ST6R5-3036GSK	62	900	ST6R5-3636GSK	75	900
48"	ST6R5-2448GSK	67	900	ST6R5-3048GSK	77	900	ST6R5-3648GSK	93	900
60"	ST6R5-2460GSK	80	610	ST6R5-3060GSK	91	610	ST6R5-3660GSK	111	610
72"	ST6R5-2472GSK	92	400	ST6R5-3072GSK	105	400	ST6R5-3672GSK	129	400
84"	ST6R5-2484GSK	111	1350	ST6R5-3084GSK	127	1350	ST6R5-3684GSK	159	1350
96"	ST6R5-2496GSK	123	1350	ST6R5-3096GSK	142	1350	ST6R5-3696GSK	177	1350
108"	ST6R5-24108GSK	136	1350	ST6R5-30108GSK	155	1350	ST6R5-36108GSK	193	1350
120"	ST6R5-24120GSK	147	1130	ST6R5-30120GSK	170	1130	ST6R5-36120GSK	211	1130
132"	ST6R5-24132GSK	159	900	ST6R5-30132GSK	184	900	ST6R5-36132GSK	228	900
144"	ST6R5-24144GSK	171	680	ST6R5-30144GSK	199	680	ST6R5-36144GSK	246	680

OVERALL WEIGHT (WT) AND MAX WEIGHT CAPACITY (WT CAP) ARE IN POUNDS (LBS). MAX WEIGHT CAPACITY EVENLY DISTRIBUTED. ALL DIMENSIONS ARE TYPICAL. TOLERANCE +/- .500". JOHN BOOS & CO. RESERVES THE RIGHT TO CHANGE SPECIFICATIONS WITHOUT NOTICE.

DETAILED SPECIFICATIONS

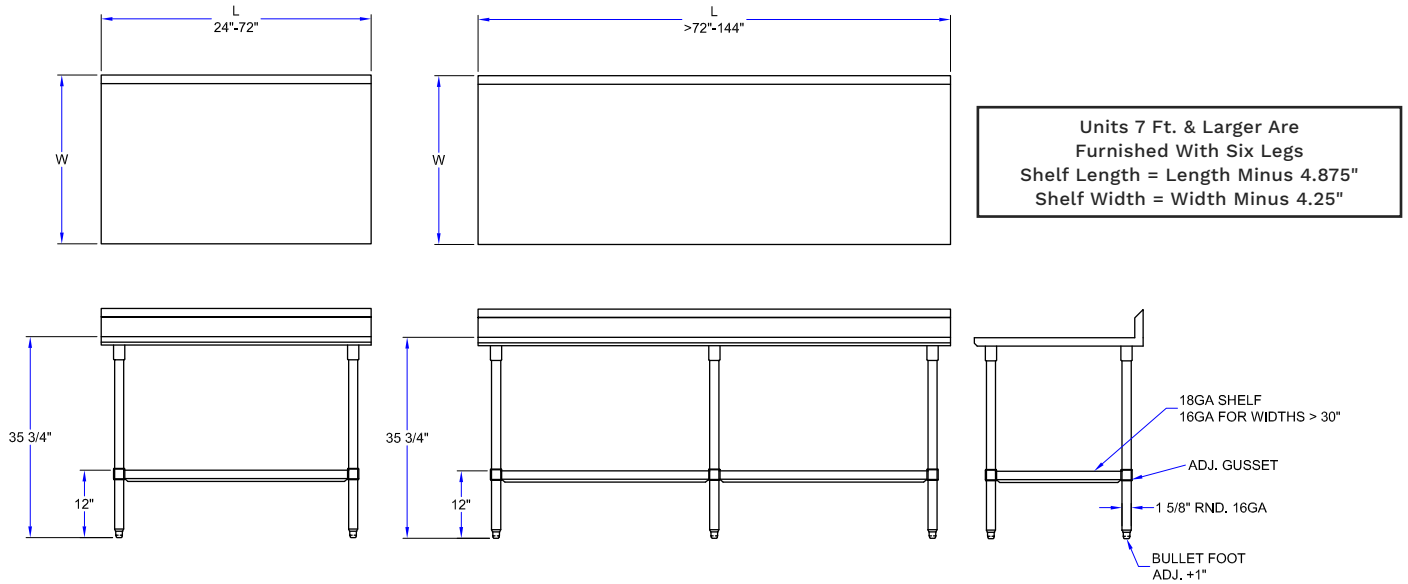

Units 7 Ft. & Larger Are
Furnished With Six Legs
Shelf Length = Length Minus 4.875"
Shelf Width = Width Minus 4.25"

MODEL # STRUCTURE

- 5 = Ht. Of Riser w/Turndown
- R = Top w/Riser
- 6 = 16GA Work Surface
- ST = Stainless Steel Top
- 24 = Width Of Work Surface
- 30 = Length Of Work Surface
- GS = Galvanized Legs & Shelf
- K = Ships Knocked Down

ST6R5-2430GSK

"ST6R5-GSK" STAINLESS STEEL TOP WORK TABLES

LENGTH	24" WIDE	WT	WT CAP	30" WIDE	WT	WT CAP	36" WIDE	WT	WT CAP
24"	ST6R5-2424GSK	44	900	ST6R5-3024GSK	49	900	ST6R5-3624GSK	58	900
30"	ST6R5-2430GSK	49	900	ST6R5-3030GSK	54	900	ST6R5-3630GSK	68	900
36"	ST6R5-2436GSK	55	900	ST6R5-3036GSK	62	900	ST6R5-3636GSK	75	900
48"	ST6R5-2448GSK	67	900	ST6R5-3048GSK	77	900	ST6R5-3648GSK	93	900
60"	ST6R5-2460GSK	80	610	ST6R5-3060GSK	91	610	ST6R5-3660GSK	111	610
72"	ST6R5-2472GSK	92	400	ST6R5-3072GSK	105	400	ST6R5-3672GSK	129	400
84"	ST6R5-2484GSK	111	1350	ST6R5-3084GSK	127	1350	ST6R5-3684GSK	159	1350
96"	ST6R5-2496GSK	123	1350	ST6R5-3096GSK	142	1350	ST6R5-3696GSK	177	1350
108"	ST6R5-24108GSK	136	1350	ST6R5-30108GSK	155	1350	ST6R5-36108GSK	193	1350
120"	ST6R5-24120GSK	147	1130	ST6R5-30120GSK	170	1130	ST6R5-36120GSK	211	1130
132"	ST6R5-24132GSK	159	900	ST6R5-30132GSK	184	900	ST6R5-36132GSK	228	900
144"	ST6R5-24144GSK	171	680	ST6R5-30144GSK	199	680	ST6R5-36144GSK	246	680

OVERALL WEIGHT (WT) AND MAX WEIGHT CAPACITY (WT CAP) ARE IN POUNDS (LBS). MAX WEIGHT CAPACITY EVENLY DISTRIBUTED.
ALL DIMENSIONS ARE TYPICAL. TOLERANCE +/- .500". JOHN BOOS & CO. RESERVES THE RIGHT TO CHANGE SPECIFICATIONS WITHOUT NOTICE.