



Project _____
 AIA # _____ SIS # _____
 Item # _____ Quantity _____ C.S.I. Section 114000

A-Series

W-Width Convertible Reach-In Model
 32" Deep, Self-Contained



STANDARD PRODUCT FEATURES

- Flip Switch to Convert the Cabinet from Refrigerator to Freezer or Freezer to Refrigerator
- Traulsen's Smart Control with LED Display
- Stainless Steel Exterior/ Anodized Aluminum Interior
- Balanced, Self-Contained Refrigeration System Using R-290
- Full or Half-Height Stainless Steel Doors with Locks
- Anti-Condensate Door Perimeter Heater
- Self-Closing Doors with Stay Open Feature at 120 Degrees
- Standard Door Hinging: 232W = Left/Right (other hingsings available)
- Automatically Activated LED Lights
- Stainless Steel Breaker Caps
- Three Adjustable, Coated Wire Shelves Per Section, Supported on Shelf Pins (factory installed)
- Automatic Non-Electric Condensate Evaporator
- Magnetic Snap-In EZ-Clean Door Gaskets
- Gasket-Protecting Raised Door Liners
- Controllable Anti-Condensate Evaporator
- Thermostatic Expansion Valve Metering Device
- Stainless Steel One-Piece Louver Assembly
- 9' Cord & Plug Attached
- Set of (4) 6" High Adjustable Stainless Steel Legs



Models listed to the applicable UL, CSA and NSF standards by an approved NRTL. Consult the factory or unit data plate for additional information.

ACCESSORIES & OPTIONS

- Stainless Steel Finished Back with Rear Louvers
- Heat Shield
- Accommodates EZ-Clean™ Tray Racks
- #1 Type Trayslides to Accommodate either (1) 18" x 26" or (2) 14" x 18" Sheet Pans
- # 4 Type Trayslides to Accommodate 18 to 19 Levels for 18" x 26" Pans
- Universal Type Trayslides to Accommodate Either (1) 18" x 26", (2) 14" x 18" Sheet Pans, or (2) 12" x 20" Steam Table Pans
- Additional Coated Wire or Optional Stainless Steel Shelves
- EZ-Open Foot Pedal (full-height doors only)
- Locking Hasps (padlocks supplied by others)
- Kool Klad Exterior Laminate Decor
- Set of (4) 6" Stainless Stee; Flanged Legs
- Set of (4) 4-1/8" or 6" High Casters in Lieu of Legs
- Other Support Options: 4 1/2" High Base or 6" High Kickplate (for use with standard legs)
- Prison/Correctional Facilities Options

AVAILABLE CONFIGURATIONS

A-Series Models
 ACV232WUT-FHS
 ACV232WUT-HHS

Door(s)
 Full Height Solid
 Half Height Solid

- GUARANTEED FOR LIFE CAM-LIFT HINGES
- GUARANTEED FOR LIFE HORIZONTAL WORK FLOW DOOR HANDLES (SOLID DOORS ONLY)

Approved by _____ Date _____ Approved by _____ Date _____

MODEL

ACV232WUT-HHS
ACV232WUT-FHS

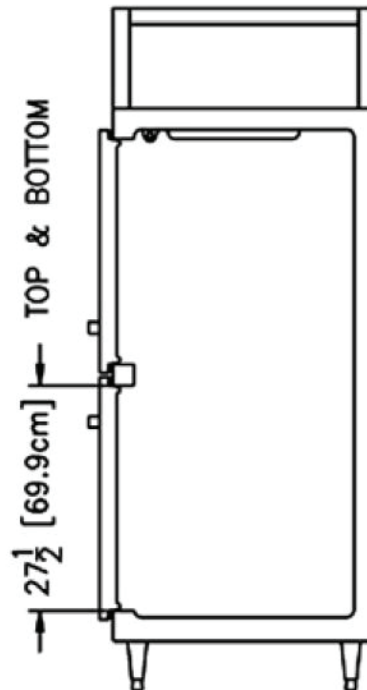
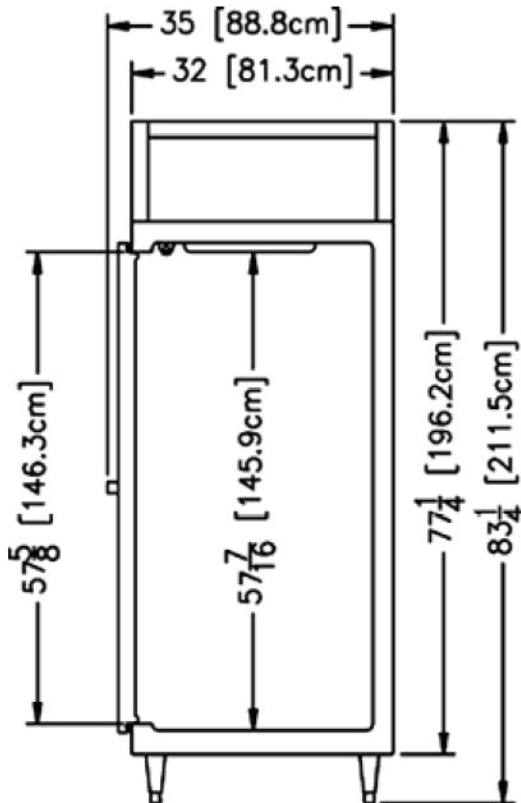
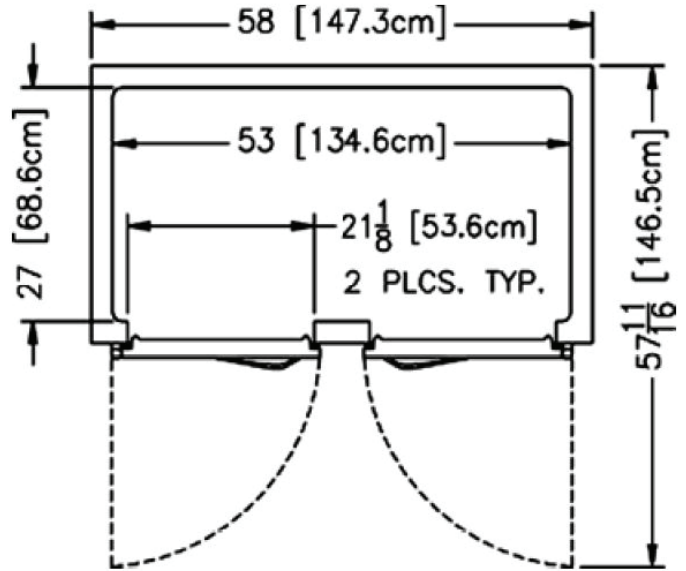
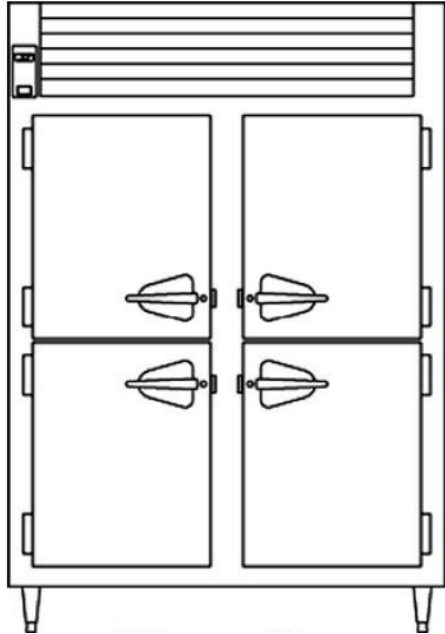

> CAD and/or Revit Files Available

<https://traulsen.klccad.com/>



MODEL

ACV232WUT-HHS
ACV232WUT-FHS

MODELS	ACV232WUT
DIMENSIONAL DATA	
Net capacity cu. ft.	51.36 (1454.4 cu l)
Length - overall in.	58" (147.3 cm)
Depth - overall in.	35" (88.8 cm)
Depth - over body in.	32" (81.3 cm)
Depth - door open 90° in.	57 11/16" (146.5 cm)
Clear door width in.	21 1/8" (53.6 cm)
Clear half-door height in.	27 1/2" (69.9 cm)
Clear full-door height in.	57 5/8" (146.3 cm)
Height - overall on 6" legs ²	83 1/4" (211.5 cm)
Shelf area sq. ft.	27.78 (2.58 sq m)
ELECTRICAL DATA	
Voltage Plug	115/60/1 NEMA 5-15P
Full Load Amperes MDEC ³	3.72 12.05 kWh/Day
REFRIGERATION DATA	
Refrigerant	R-290
Refrigerant Charge Amount oz.	5.29 (149.97 g)
BTU/HR H.P. ¹	3660 1 1/4 HP
SHIPPING DATA	
Length - Crated in.	62" (157.5 cm)
Width - Crated in.	42" (106.7 cm)
Height - Crated in.	85" (215.9 cm)
Volume - Crated cu. ft.	128 (3624.6 cu l)
Weight - Crated lbs.	610 (276.6 kg)

NOTES: Figures in parentheses reflect metric equivalents.

1. Based on a 90°F ambient and -10°F evaporator.
2. 12" Top clearance preferred for optimum performance & service access.
3. MDEC = Maximum Daily Energy Consumption

When ordering please specify: Voltage, Hinging, and Options.

Equipped with one NEMA 5-15P Plug 

EQUIPMENT SPECIFICATIONS

CONSTRUCTION, HARDWARE, INSULATION

Cabinet exterior front, one piece sides, louver assembly & doors are constructed of heavy gauge stainless steel. Cabinet interior & door liners are also constructed of anodized aluminum. The exterior cabinet top, back & bottom are constructed of heavy gauge galvanized steel. A set of four (4) adjustable 6" high stainless steel legs are included.

Doors are equipped with removable plug cylinder locks & guaranteed for life cam-lift, gravity action, self-closing metal, glide hinges with stay open feature at 120 degrees. Hinges include a switch to automatically activate the interior LED lighting. Guaranteed for life, work flow door handles are mounted horizontally over recess in doors which limit protrusion from door face into aisleways.

Gasket profile & EZ-Clean material simplify cleaning & increase overall gasket life. Anti-condensate heaters are located behind the door opening. Both the cabinet & doors are insulated with high density, non-CFC, foamed in place polyurethane.

SELF-CONTAINED REFRIGERATION SYSTEM

A top mounted, self-contained, balanced refrigeration system using R-290 refrigerant is conveniently located behind the one piece louver assembly. It features a high humidity evaporator coil located outside the food zone, top mounted non-electric condensate evaporator, & an automatic preset time activated electric defrost. A face mounted key switch is provided to convert operation from freezer to refrigerator mode. Standard operating temperature in freezer mode is -10 to 0°F. Operating temperature in refrigerator mode is 34-38°F. Operating temperatures are not adjustable.

CONTROL

Traulsen's Smart Control features advanced control algorithms & sophisticated diagnostic capabilities to optimize performance. Utilizing Smart Sensors, it adapts the operation of the refrigeration system to a variety of environments & usage patterns. The Smart Control also offers a complete set of visual alarms designed to alert the user to critical events such as power outages or a prolonged door opening. In the event of an alarm, a dedicated Alarm LED will illuminate, informing the user of the critical event and duration.

INTERIOR

Standard interior arrangements include three (3) coated wire shelves per section, mounted on shelf pins. Shelves are full-width & do not have any large gaps between them requiring the use of "bridge" or "junior" shelves. Recommended load limit per shelf should not exceed 225 lbs. Optional trayslides may be purchased in combination with, or in lieu of these. Interior arrangements are factory-installed & EZ-Change interior slides (only) are field installed.

WARRANTY

Both a six year parts and labor warranty and a seven year compressor warranty (self-contained models only) are provided standard.

CONTINUED PRODUCT DEVELOPMENT MAY NECESSITATE SPECIFICATION CHANGES WITHOUT NOTICE.