



ATLAS METAL

1135 N.W. 159th DRIVE, MIAMI, FLORIDA 33169

TEL 305.625.2451

TOLL FREE 800.762.7565

FAX 305.623.0475

WWW.ATLASFOODSERV.COM

SALES@ATLASFOODSERV.COM

Project: _____

Item No.: _____

Quantity: _____

MODULAR UNITS CA SERIES



CAPT-4 SHOWN WITH ACCESSORIES

COLD FOOD UNIT

Refrigerated
Pass-Through

CAPT-3

CAPT-4

SPECIFICATIONS

TOP: Constructed of 16 gauge, type 304 stainless steel, die-formed, welded, ground and polished. The top is provided with an opening to receive the appropriately sized drop-in unit. An integral locking device shall be provided to align and retain cart positioning when two or more carts are joined.

BODY: Frame construction shall be of hi-tensile aluminum square tubing, 1-1/4" x 1-1/4". Frame sections are welded construction, ground and polished to a uniform finish. Body is complete with front panel and 7" rear apron of plastic laminate on .063 aluminum. Owner to specify finish.

DISPLAY CASE: The cart includes a WCPT Series drop-in refrigerated display case installed in the top. Double wall constructed of type 304 stainless steel - 20 gauge, both interior and exterior, and filled with 2" of foamed-in-place polyurethane insulation. Customer's side and operator's side are provided with a set of two (2) sliding, self-closing, thermo-pane insulated glass doors. The doors are removable for ease of cleaning. The display case is provided with two (2) plastic coated wire shelves, adjustable on 1" increments, and two (2) sets of fluorescent light fixtures mounted behind plastic guards which are recessed into the side panels. The light fixtures are provided with a separate on/off switch. An internal thermometer is provided.

REFRIGERATED SYSTEM: The compressor housing shall be fabricated from formed 14 gauge galvanized and bolted to the base of the unit. A fully self-contained condensing unit is provided, with a hermetically sealed compressor and a thermostat control. The system is also provided with a forced air evaporator for even temperature throughout the display case, which drains into a condensate evaporator pre-wired in the unit. The system is fully charged with CFC free refrigerant and ready to operate.

ELECTRICAL: The unit will be wired for 15 amps., 120 volt, single phase operation, with an on/off thermostat switch and pilot light. A 6' long, 3-wire cord and plug (NEMA 5-15P) will be provided.

CASTERS: The casters shall be 5" diameter, non-marking rubber tired, swivel type with ball bearings in both swivel and axle raceways, provided with grease fittings. Both casters on operator's side have toe activated brakes.

Specifications subject to change without notice.

STANDARD FEATURES

- Large lighted display area with adjustable shelves - it's the ideal merchandiser
- Sliding glass doors on customer's and operator's side, makes loading and self-service move quickly
- Forced air evaporator blower system for maximum efficiency in cooling
- Self-contained refrigeration system - just plug it in and turn it on
- Positive self-locking device - keeps tops level and equipment in place
- Fully mobile - each unit is provided with 5" dia. swivel casters, two with brakes
- Versatile - available in a wide range of sizes and a wide variety of finishes and colors
- 1-Year Parts & Labor Warranty
- UL Listed

ACCESSORIES

- **SL** - Tray Slide, 11-1/4" wide, S/S, 2-rail, fold-down
- **SLT** - Tray Slide, 11-1/4" wide, S/S, 3-rail, fold-down
- **SLS** - Tray Slide, 11-1/4" wide, S/S solid, ribbed, fold-down
- **SLF** - Tray Slide, 11-1/4" wide, plastic laminate with S/S runners, fold-down
- **SH** - Work Shelf, 8" wide, S/S, fold-down
- **CB** - Work Shelf, 8" wide, hardwood maple, fold-down
- **CR** - Work Shelf, 8" wide, Richlite, fold-down
- **ES** - End Shelf, 16" wide, S/S, fold-down
- **CBE** - End Shelf, 16" wide, hardwood maple, fold-down
- **EPA** - End Panel, aluminum w/ plastic laminate (each)
- **S** - S/S Front Panel
- **EPS** - S/S End Panel (each)
- **PP** - Painted Panels, urethane, in lieu of laminate
- **US** - Undershef, S/S, removable
- **RPS** - Rear Sliding Doors, removable
- **HD** - Hinged Doors, S/S
- **DL** - Door Locks (set)(For **RPS** or **HD**)
- **CO** - Convenience Outlet (specify base or apron mount)
- **CO-DUP** - Convenience Outlet, Duplex receptacle
- **JBC** - Outlet Box in base, 4x4 (120V) with cord
- **ERS** - Electrical Raceway System
- **PCS** - 7 to 10 ft. Power Cord
- **CW** - Cord Wrap
- **P-CAST** - Polyurethane Casters, 2-W/Brakes
- **Legs** with adjustable feet in lieu of casters
- **BSF** - Front Skirt with recessed casters
- **BSE** - End Skirt (each)
- **BSR** - Rear Skirt
- **REM-COMP** - Remote Compressor on base of unit w/ louvered S/S compartment & remote on/off switch in apron
- **5YW** - 5-Year Compressor Warranty
- **RDVE** - Rear Drain Valve Extension
- **Door Locking Device** for glass sliding doors (2 required)
- **Extra Shelf** - 3
- **Extra Shelf** - 4
- **Plastic Laminate Trim**
- **Tempered Reflective Vision Panel**, bronze or gray
- **Sliding Doors with reflective tempered vision panel**, bronze or gray
- **RS** - Remote on/off switch
- ***220 Volt - 50 Cycle Compressor**

* Units with these accessories are not currently UL listed.

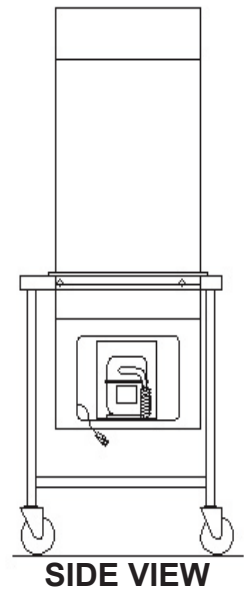
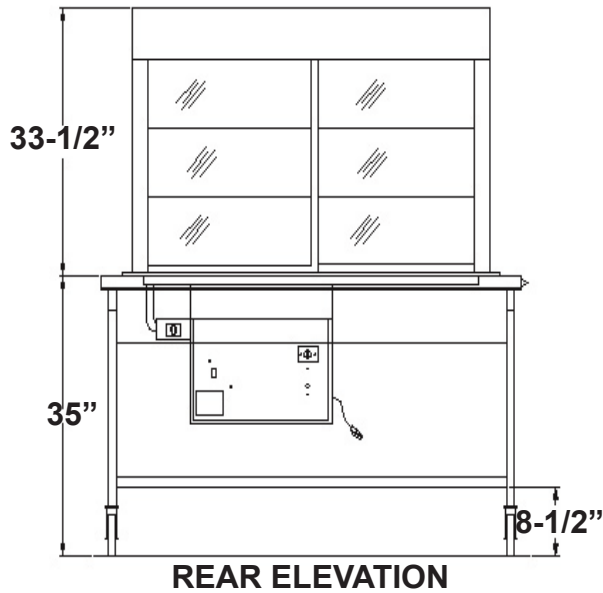
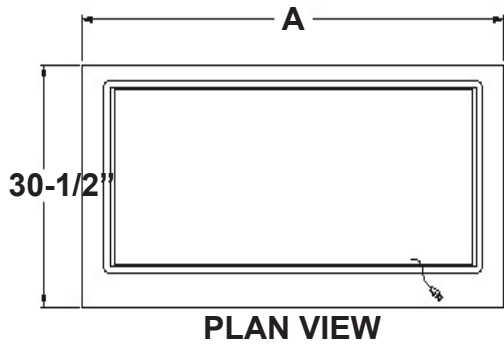
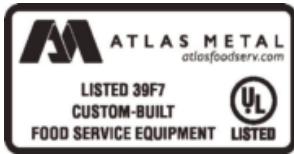

MODEL	"A"	ELECTRICAL CHARACTERISTICS	CUBIC FEET	SHIP WT. (LBS)
CAPT-3	50" (127cm)	13.5 amps. - 120V - 1/2 HP	12 CU. FT.	590 (267.6kg)
CAPT-4	63-3/4" (161.9cm)	13.5 amps - 120V - 1/2 HP	16 CU. FT.	680 (308.4kg)