

Combi oven

Project _____
 Item _____
 Quantity _____
 FCSI section _____
 Approval _____
 Date _____

Convotherm maxx pro
 easyTouch

- 6.20
- 7 slide rails
- Electric
- Boiler
- Right-hinged door



Key Features

- Advanced Closed System+ (ACS+) cooking methods: Steam, combi-steam, hot air
- Advanced Closed System+ (ACS+) with extra functions:
 - Crisp&Tasty - 5 moisture-removal settings
 - BakePro - 5 levels of traditional baking
 - HumidityPro - 5 humidity settings
 - Controllable fan - 5 speed settings
- easyTouch 10" TFT high-resolution glass touch display (capacitive)
- ConvoClean+ fully automatic cleaning system with eco, regular and express modes - with optional single-dose dispensing
- HygieniCare
- WiFi and Ethernet port (LAN)
- TriColor indicator ring - indicates the current operating status
- Steam generated by high-performance boiler outside the cooking chamber
- LED illumination for cooking chamber
- Triple-glazed right-hinged unit door
- UL KNLZ listed for ventless operation, local codes prevail as in NFPA 96-1994 & UL 710B (ConvoSmoke effects UL KNLZ listing)

Standard features

- Cooking methods:
 - Steam (86-266°F) with guaranteed steam saturation
 - Combi-steam (86-482°F) with automatic humidity adjustment
 - Hot air (86-482°F) with optimized heat transfer
- easyTouch user interface controls:
 - 10" TFT high-resolution glass touch display (capacitive)
 - Smooth-action, quick-reacting scrolling function
- Climate Management
 - Advanced Closed System+ (ACS+), HumidityPro, Crisp&Tasty
- Quality Management
 - Airflow Management, BakePro, multi-point core temperature probe, preheat and cool-down function
- Production Management
 - Automatic cooking with Press&Go with up to 399 profiles
 - Integrated cookbook with 7 different categories
 - TrayTimer - load management for different products simultaneously
 - TrayView - load management for automatic cooking of different products using Press&Go
 - Favorites management
 - HACCP data storage
 - USB port
 - ecoCooking - energy saving function
 - LT cooking (low-temperature cooking) / Delta-T cooking
 - Cook&Hold - cooking and keeping food warm in a single process
 - Auto Start
 - Rethermalization+: versatile multi-mode rethermalization function

Standard features

- Cleaning Management:
 - ConvoClean+: Fully automatic cleaning system
 - Quick access to individually created and stored cleaning profiles
 - Cleaning Scheduler
- HygieniCare:
 - Hygienic Steam Function
 - Hygienic handles
 - SteamDisinfect
- Design:
 - Triple-glazed right-hinged unit door with safety lock, sure-shut function, venting position, and LEDs for illuminating the cooking chamber
 - Steam generated by boiler
 - Adjustable feet with adjustment range between 4 inches and 5 inches
 - Multi-point core temperature probe
 - Integrated recoil hand shower

Commercial combination oven with integral systems for limiting the emissions of grease-laden air. This product conforms to the ventless operation recommendations set forth by NFPA96 & UL 710B using EPA202 test method. (Not valid for ConvoSmoke units)



C4eT 6.20 EB-N

Options

Accessories

Convotherm maxx pro easyTouch

- 6.20
- 7 slide rails
- Electric
- Boiler
- Right-hinged door



Key Features

- Advanced Closed System+ (ACS+) cooking methods: Steam, combi-steam, hot air
- Advanced Closed System+ (ACS+) with extra functions:
 - Crisp&Tasty - 5 moisture-removal settings
 - BakePro - 5 levels of traditional baking
 - HumidityPro - 5 humidity settings
 - Controllable fan - 5 speed settings
- easyTouch 10" TFT high-resolution glass touch display (capacitive)
- ConvoClean+ fully automatic cleaning system with eco, regular and express modes - with optional single-dose dispensing
- HygieneCare
- WiFi and Ethernet port (LAN)
- TriColor indicator ring - indicates the current operating status
- Steam generated by high-performance boiler outside the cooking chamber
- LED illumination for cooking chamber
- Triple-glazed right-hinged unit door
- UL KNLZ listed for ventless operation, local codes prevail as in NFPA 96-1994 & UL 710B (ConvoSmoke effects UL KNLZ listing)

Options

- Triple-glazed disappearing door - more space and added safety (see page 3)
- Quality Management:
 - ConvoSmoke - built in food-smoking (HotSmoke)
 - ConvoGrill with grease management function
- Steam and vapor removal - built-in condenser
- Corrections package
- Available in various voltages
- Sous-vide probe, external connection
- Core temperature probe, external connection (internal core probe standard)

Accessories

- KitchenConnect® (WiFi/LAN), network solution from Welbilt for updating and monitoring appliances from anywhere
- Signal Tower
- Racks
- Banquet system (optionally as a package or individually): Plate rack, mobile shelf rack, transport trolley, thermal cover
- Stacking stands
- Equipment stands in various sizes and designs

Accessories and services by partners

- ConvoVent 4 condensation hood by Halton
- Cleaning chemicals for the fully automatic ConvoClean+ cleaning system (multiple-dose and single-dose dispensing)
- Water filtration and reverse osmosis systems and replacement filters
- Installation services available - details in AutoQuotes - availability may vary by region
- Cooking, baking, and roasting cookware

Front view

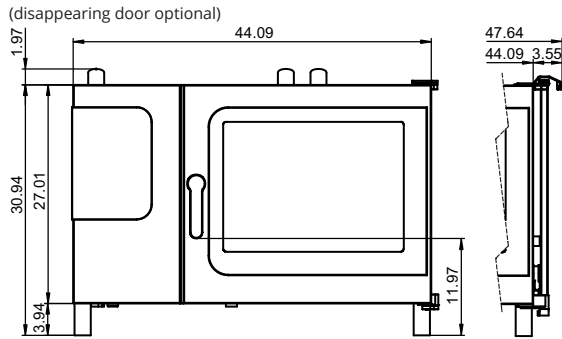

Connection points, bottom of unit

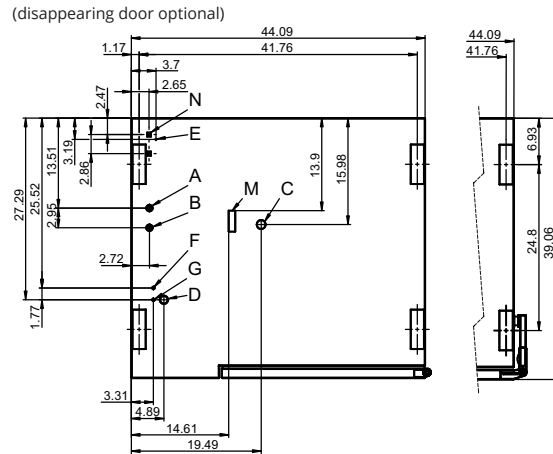

View from above with wall clearances

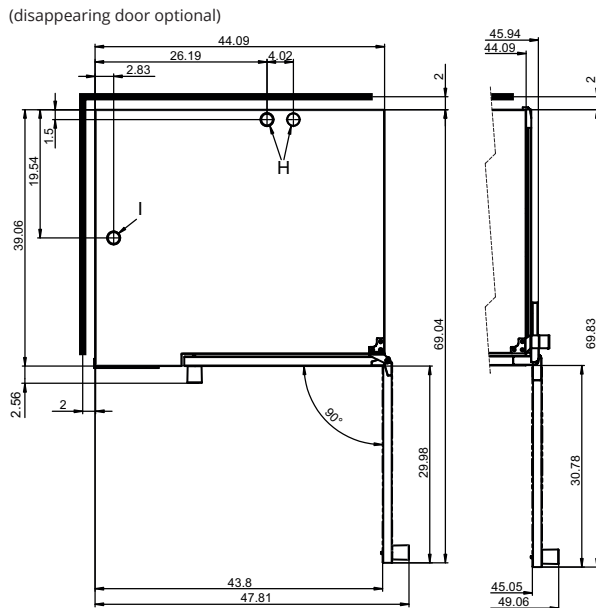

- A Water connection (for boiler)
- B Water connection (for cleaning, recoil hand shower)
- C Drain connection (2" I. D.)
- D Electrical connection
- E Equipotential bonding
- F Rinse-aid connection
- G Cleaning-agent connection
- H Air vent (2" I. D.)
- I Dry air intake 2"
- M Safety overflow 3.2" x 1"
- N Ethernet connection RJ45

Dimensions and weights

Dimensions including packaging	
Width x height x depth	53.7" 41.3x" 45.7x"
Weight	
Net weight without options* / accessories	335 lbs
Packaging weight	77 lbs
Safety clearances**	
Rear	2"
Right (right-hinged door)	2"
Right (disappearing door pushed back)	5"
Left (see installation requirements)	2"
Top***	20"

Installation requirements

Clearance from heat sources	min. 20"
Recommended clearance for servicing on the left side of the unit	min. 20"

The combi oven must be easily accessible on three sides in order to ensure accessibility for cleaning. Alternatively, use a 6" foot, available upon request.

* Max. weight of options: 33 lbs.

** Required for the unit to work properly.

*** Depends on the type of exhaust system and the ceiling's characteristics.

Loading capacity

Max. number of food containers	
[Unit has 7 slide rails; rail spacing 2.68" max.]	
Steam table pans (12"x20"x1")	14
Steam table pans (12"x20"x2.5")	14
Wire shelves, full size (20"x26")	7
Sheet pans, full size (18"x26")*	6
Sheet pans, half size (13"x18")*	12
Frying baskets, half size (12"x20")	14
Plates (optional plate rack)	27
Max. loading weight	
Per combi oven	132 lbs
Per shelf level	33 lbs

* Wire shelves required.

Electrical supply

208V 3PH 60Hz / 240V 3PH 60Hz *	
Rated power consumption	15.9 / 21.0 kW
Rated current	44.1 / 50.6 A
Power supply wire gauge	6 AWG
Conductor insulation rating	194 °F / 90 °C
When using the ConvoSmoke option, the only available voltage options are:	
440V 3PH 60Hz / 480V 3PH 60Hz *	
Rated power consumption	16.3 / 19.3 kW
Rated current	21.4 / 23.3 A
Power supply wire gauge	8 AWG
Conductor insulation rating	194 °F / 90 °C
208V 3PH 60Hz *	
Rated power consumption	15.9 kW
Rated current	44.1 A
Power supply wire gauge	6 AWG
Conductor insulation rating	194 °F / 90 °C
240V 3PH 60Hz *	
Rated power consumption	21.0 kW
Rated current	50.6 A
Power supply wire gauge	6 AWG
Conductor insulation rating	194 °F / 90 °C

* Prepared for connection to an energy optimizing system.

Water connection

Water supply	
Water supply	2 x 3/4" GHT-M garden hose adapter; Alternative, 2 hoses 1/2" inner diameter with one side 3/4" GHT-F to 3/4" BST. The unit is designed for a fixed connection to the water supply using a connecting hose with a minimum inner diameter of 1/2"
Flow pressure	22 - 87 psi / 1.5 - 6 bar
Drain	
Drain version	Naturally ventilated pipe to open pan or drain/channel
Type	2" inner diameter
Slope for drainpipe	min. 3.5% (2°)

Water quality

Water connection A* for boiler,
Water connection B* for cleaning, recoil hand shower

General requirements	Drinking water, typically untreated water
TDS	70 - 360 ppm
Hardness**	70 - 360 ppm (4 - 21 gpg)
pH value	6.5 - 8.5
Cl ⁻ (chloride)	max. 60 ppm
Cl ₂ (free chlorine)	max. 0.2 ppm
SO ₄ ²⁻ (sulfate)	max. 150 ppm
Fe (iron)	max. 0.1 ppm
SiO ₂ (silica)	max. 13 ppm
NH ₂ Cl (monochloramine)	max. 0.2 ppm
Temperature	max. 104°F / max. 40°C

* Please refer to the connection points diagram, p. 2.

** Even if the limits are adhered to, deposits of minerals that do not cause hardness may occur in certain cases. Any measures used to prevent this must be clarified with Technical Support.

NOTICE: The owner/operator/purchaser must ensure that the water quality requirements are met. Otherwise the unit warranty is void.

Water consumption

Water connections A, B	
Average consumption for cooking**	1.9 gph
Max. water throughput	4.0 gpm

** Incl. water required for cooling the wastewater.

NOTICE: See connection positions diagram, p. 2.

Emissions

Heat loss	
Latent	3100 BTU/h
Sensible	4000 BTU/h
Drain temperature	max. 140°F / 60°C
Decibel rating	max. 70 dBA

ACCESSORIES

(For more detailed information, please refer to the Accessories brochure.)

Stacking kit

Combinations allowed	6.20 on 6.20 6.20 on 10.20
If combining two electrical units	
Select the "stacking kit for Convotherm 4 electrical units"	
If combining one electrical unit and one gas unit in a stacking kit	
Select the "stacking kit for Convotherm 4 electrical units" if:	
Bottom combi oven	EB/ES
Top combi oven	GB/GS
Select the "stacking kit for Convotherm 4 gas units" if:	
Bottom combi oven	GB/GS
Top combi oven	EB/ES

Equipment stand

Standard support surface height	26.38"
---------------------------------	--------

ACCESSORIES BY PARTNERS

ConvoVent 4 condensation hood by Halton*

Electrical supply	
Rated voltage	120V 1PH 60Hz
Rated power consumption	84 - 360 W
Rated current	0.7 - 3.0 A
Power supply wire gauge	AWG 14
Plug (preinstalled)	NEMA 5-15
Dimensions without packaging	
Width x height x depth	44.4 x 12.7 x 49.5 "
Weight without packaging	228 lbs
Top safety clearance**	20 "

* Special condensation hoods are available for stacking kits.

**Depends on the type of exhaust system and the ceiling's characteristics.