

# QTCR-4 SYSTEM

## FOODSERVICE WATER TREATMENT SYSTEM

QTCR-4: 170-52134

Replacement Cartridge: CTO-QCR2 300-05833



### APPLICATIONS

- ◆ Fountain beverages

### FEATURES • BENEFITS

- ◆ Reduces maintenance frequency and cost, and extends equipment life.
- ◆ Gradient-density sediment filtration protects against dirt, rust and other debris.
- ◆ High-capacity activated-carbon filtration makes water taste great and protects equipment against corrosive chlorine.
- ◆ New manifold design provides fewer possible leak points.
- ◆ Sturdy, powder-coated mounting bracket and multi-function valve simplify installation.
- ◆ Multi-function valve provides:
  - ◆ Shutoff valve for quick and simple filter replacements
  - ◆ System bypass valve for easy system maintenance
  - ◆ Flush port to flush cartridges after installation
- ◆ Built-in pressure gauge allows visual monitoring of when filters need to be changed.
- ◆ Utilizes Qwik-Twist cartridges that make changing filters quick, easy and sanitary.

### INSTALLATION TIPS

- ◆ Feed-water connection to system should be COLD only.
- ◆ Do not exceed system specifications for temperature and pressure.
- ◆ Allow 3" clearance below system for filter cartridge removal and replacement.
- ◆ Detailed installation, operation and maintenance manual included with each system.

### OPERATION TIPS

- ◆ Change cartridges on a regular six (6) month preventative maintenance program.
- ◆ Change cartridges when capacity is reached or when flow becomes too slow.
- ◆ Always flush the filter cartridge at time of installation and cartridge change.

### SIZING

- ◆ Service Flow Rate: 6.8 gpm (25.7 lpm)
- ◆ Rated Capacity: 40,000 gals. (151,400 L)

# QTCR-4 SYSTEM

170-52134

QTCR-4: 170-52134

Replacement Cartridge: CTO-QCR2 300-05833

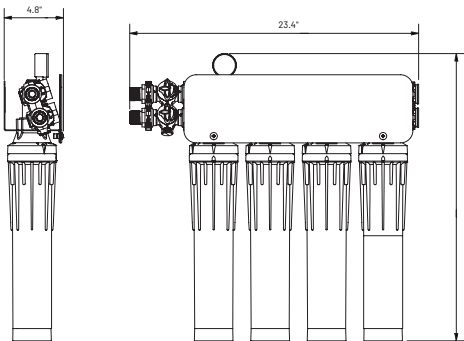

## SPECIFICATIONS

- ◆ **Service Flow Rate**  
Maximum 6.8 gpm (25.7 Lpm)
- ◆ **Rated Capacity**  
40,000 gallons (151,400 L)
- ◆ **Pressure Requirements**  
10 – 125 psi (0.7 – 8.6 bar), non-shock
- ◆ **Temperature**  
35 – 100°F (2 – 38°C)
- ◆ **Overall Dimensions**  
23.3" L x 23.4" W x 4.8" D  
59.2 cm x 59.4 cm x 12.2 cm
- ◆ **Inlet Connection**  
Inlet Connection: 3/4" MNPT
- ◆ **Outlet Connection**  
Outlet Connection: 3/4" MNPT
- ◆ **Shipping Weight**  
16 lbs (7.3 kgs)
- ◆ **Electrical Connection**  
None required



System certified by IAPMO R&T to NSF/ANSI Standard 42:

**AESTHETIC EFFECTS**  
Chemical Reduction  
Chlorine, Chloramine, Taste & Odor  
Mechanical Filtration  
Nominal Particulate Class III

## WARRANTY

Everpure water treatment systems by Pentair (excluding replaceable elements) are covered by a limited warranty against defects in material and workmanship for a period of five years after date of purchase. Everpure replaceable elements (filter cartridges and water treatment cartridges) are covered by a limited warranty against defects in material and workmanship for a period of one year after date of purchase. See printed warranty for details. Pentair will provide a copy of the warranty upon request.

The contaminants or other substances removed or reduced by this drinking water system are not necessarily in your water. Do not use with water that is microbiologically unsafe or of unknown quality without adequate disinfection before or after the system.

Since the conditions under which our products may be used are beyond our control, we cannot accept any liability with respect to the improper installation, application and/or use of our products.



**United States** | 1040 Muirfield Drive | Hanover Park, IL 60133 | 800.942.1153 (US Only) 630.307.3000 Main | [cseverpure@pentair.com](mailto:cseverpure@pentair.com) | [foodservice.pentair.com](http://foodservice.pentair.com)

**Australia** | 1-21 Monash Drive | Dandenong South, Vic 3175 | Australia | 011.1300 576 190 Tel | [au.everpure@pentair.com](mailto:au.everpure@pentair.com)

**China** | 21F Cloud 9 Plaza, N0 1118 | Shanghai, 200052 | China | 86.21.3211.4588 Tel | [china.water@pentair.com](mailto:china.water@pentair.com)

**India** | Boulevard, B-9/A, 7th Floor - Tower B Sector 62 | Noida - 201301 | 91.120.419.9444 Tel | [indiacustomer@pentair.com](mailto:indiacustomer@pentair.com)

**Europe** | Pentair Water Belgium BVBA | Industriepark Wolfstee, Toekomstlaan 30, B-2200 Herentals | Belgium | +32.(0).14.283.504 Tel | [sales@everpure-europe.com](mailto:sales@everpure-europe.com)

**Japan** | Japan Inc. | Hashimoto MN Bldg. 7F, | 3-25-1 Hashimoto, Midori-ku, Sagami-hara-shi | Kanagawa 252-0143 | Japan | 81.(0)42.775.3011 Tel | [info@everpure.co.jp](mailto:info@everpure.co.jp)

**Southeast Asia** | 390 Havelock Road, | #04-01 King's Centre | Singapore 169662 | 65.6768.5800 Tel | [cseverpure@pentair.com](mailto:cseverpure@pentair.com)

All indicated Pentair trademarks and logos are property of Pentair. Third party registered and unregistered trademarks and logos are the property of their respective owners. Because we are continuously improving our products and services, Pentair reserves the right to change specifications without prior notice. Pentair is an equal opportunity employer.