

50-LITER BOWL CUTTER

Item: 10879

Model: FP-ES-0050

Bowl cutting produces as much as 15% higher finished product yield. Bowl cutting also allows the use of up to 30% more water and results in less shrinkage.



FOOD EQUIPMENT

50-LITER BOWL CUTTER



Standard

- 2 independent motors (bracket knife and bowl)
- Two 2 speed motors
- 6 knife head and compensating rings to use for 3-knife head
- Anti-noise lid
- All stainless steel
- Water resistant switchboard

Optional

- Slow knife mixing speed in 2 directions

TECHNICAL DRAWING & DIMENSIONS

Item: 10879

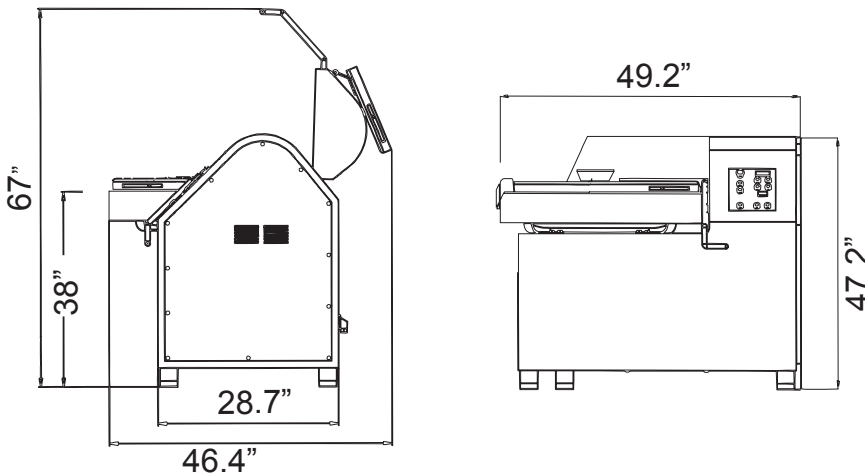

Front lid

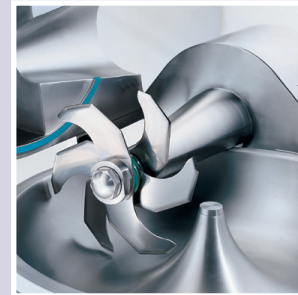

Standard removable 6 and 3-knife head

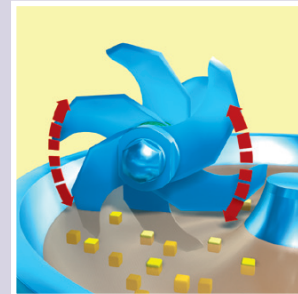

Optional slow knife mixing speed in 2 directions

TECHNICAL SPECIFICATION

ITEM NUMBER	10879
MODEL	FP-ES-0050
BOWL VOLUME	50 L / 13 gal
MIXTURE BOWL CAPACITY (APPROX.)	37 kg./81.5 lbs.
KNIFE HORSEPOWER	12/15 HP
KNIFE SPEED	2200/4300 RPM
BOWL HORSEPOWER	0.7/1.5 HP
BOWL SPEED	11/21 RPM
ELECTRICAL	220V/60/3
WEIGHT	1322.75 lbs./ 600 kg.
PACKAGING WEIGHT	1650 lbs./ 748 kg.
DIMENSIONS (DWH)	46.4" x 49.2" x 47.2" / 1178 x 1249.7 x 1199 mm
PACKAGING DIMENSIONS	55" x 47" x 55" / 1397 x 1194 x 1397 mm

OMCAN INC.

Telephone: 1-800-465-0234
 Fax: (905) 607-0234
 E-mail: sales@omcan.com
 Website: www.omcan.com



Follow us to keep up to date with the latest news and offers



2015.E.O.E