



Profit from the Eagle Advantage®

# Specification Sheet

## Short Form Specifications

Eagle Q-LEVER® Cantilever Add-On Shelving, model \_\_\_\_\_, 4-Tier add-on units feature one 76"-high upright, three wire shelves, and bottom dunnage shelf. Maximum accessibility and productivity. No wall bolting required. Upright utilizes adjustment in 2" increments without the use of tools. Shelves offered with Valu-Master® gray or Valu-Gard® green epoxy finish. Valu-Master® gray epoxy on upright.



### Options / Accessories

- Wall Grids
- Hanger Rails
- Supply Bins
- Storage Baskets
- 36", 56", 66", or 86" optional height.

### EAGLE GROUP

100 Industrial Boulevard  
Clayton, DE 19938-8903 USA

Phone: 302-653-3000 • 800-441-8440

Fax: 302-653-2065

www.eaglegrp.com • www.eaglemhc.com

For custom configuration or fabrication needs, contact our SpecFAB® Division.

Phone: 302-653-3000 • Fax: 302-653-2065 • e-mail: quotes@eaglegrp.com

Item No.:	_____
Project No.:	_____
S.I.S. No.:	_____

## Q-LEVER® Cantilever Shelving— 4-Tier Add-On Units with Bottom Dunnage Shelf, 76" Height

### MODELS:

- |                                   |                                   |                                   |                                   |
|-----------------------------------|-----------------------------------|-----------------------------------|-----------------------------------|
| <input type="checkbox"/> Q1824*4D | <input type="checkbox"/> Q2124*4D | <input type="checkbox"/> Q2424*4D | <input type="checkbox"/> Q3030*4D |
| <input type="checkbox"/> Q1830*4D | <input type="checkbox"/> Q2130*4D | <input type="checkbox"/> Q2430*4D | <input type="checkbox"/> Q3036*4D |
| <input type="checkbox"/> Q1836*4D | <input type="checkbox"/> Q2136*4D | <input type="checkbox"/> Q2436*4D | <input type="checkbox"/> Q3042*4D |
| <input type="checkbox"/> Q1842*4D | <input type="checkbox"/> Q2142*4D | <input type="checkbox"/> Q2442*4D | <input type="checkbox"/> Q3048*4D |
| <input type="checkbox"/> Q1848*4D | <input type="checkbox"/> Q2148*4D | <input type="checkbox"/> Q2448*4D | <input type="checkbox"/> Q3054*4D |
| <input type="checkbox"/> Q1854*4D | <input type="checkbox"/> Q2154*4D | <input type="checkbox"/> Q2454*4D | <input type="checkbox"/> Q3060*4D |
| <input type="checkbox"/> Q1860*4D | <input type="checkbox"/> Q2160*4D | <input type="checkbox"/> Q2460*4D | <input type="checkbox"/> Q3066*4D |
| <input type="checkbox"/> Q1866*4D | <input type="checkbox"/> Q2166*4D | <input type="checkbox"/> Q2466*4D | <input type="checkbox"/> Q3072*4D |
| <input type="checkbox"/> Q1872*4D | <input type="checkbox"/> Q2172*4D | <input type="checkbox"/> Q2472*4D |                                   |

\* See charts on back page for complete model numbers.

### Design & Construction Features

- Includes one 76" upright, two braces, three wire shelves, three pairs of brackets, one dunnage shelf, X-brace assembly, and hardware.
- Cantilevered design improves accessibility and productivity.
- Wall bolting not required.
- Upright utilizes 2" adjustment for shelf and accessory spacing.
- Shelves and accessories can be easily adjusted without tools
- Shelves can be added to the left or right of an existing unit.
- Sizing available:
  - Widths: 18"; 21"; 24"; 30"
  - Lengths: 24"; 30"; 36"; 42"; 48"; 54"; 60"
  - Height (standard): 76"
- Choice of Valu-Master® gray or Valu-Gard® green epoxy finish on the shelves.
- Valu-Master® gray epoxy finish on upright.

### Certifications / Approvals



AutoQuotes



Spec sheets available for viewing, printing or downloading from our online literature library at [www.eaglegrp.com](http://www.eaglegrp.com)

Eagle Foodservice Equipment, Eagle MHC, and SpecFAB® are divisions of Eagle Group. ©2022 by the Eagle Group



Profit from the Eagle Advantage®

Item No.: \_\_\_\_\_  
 Project No.: \_\_\_\_\_  
 S.I.S. No.: \_\_\_\_\_

## Q-LEVER® Shelving—4-Tier Add-Ons with Dunnage, 76" Height

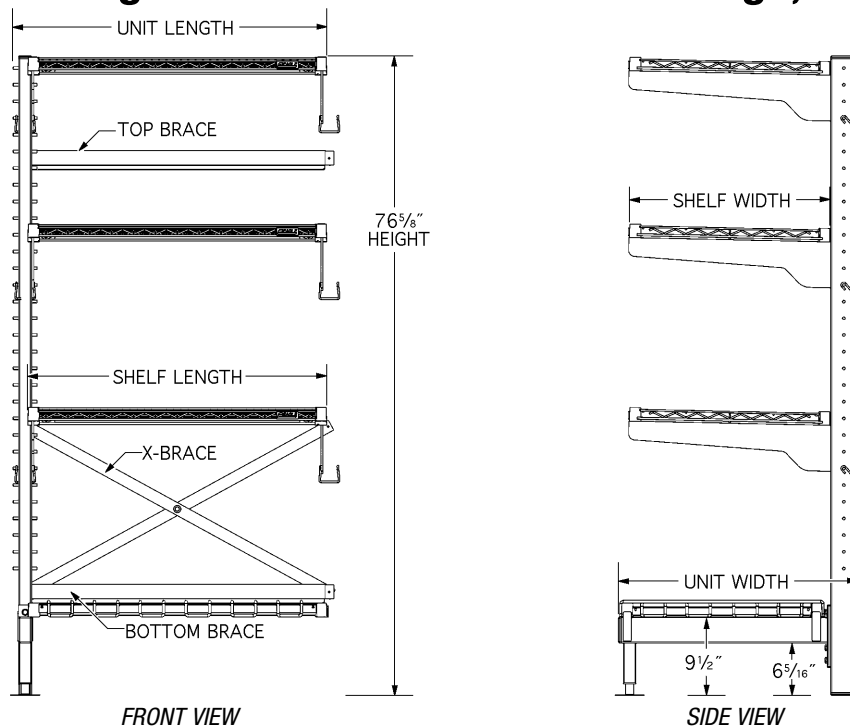

shelf length in. mm	unit** length in. mm	...WITH 18" (457mm)- WIDE SHELVES *		...WITH 21" (533mm)- WIDE SHELVES *		...WITH 24" (610mm)- WIDE SHELVES *		...WITH 30" (762mm)- WIDE SHELVES *							
		weight lbs. kg	model #	weight lbs. kg	model #	weight lbs. kg	model #	weight lbs. kg	model #						
<b>Units with Valu-Master® Grey Epoxy Coated Shelves</b>															
24"	610	25 1/2"	648	114	52	Q1824V76A-4D	125	57	Q2124V76A-4D	131	59	Q2424V76A-4D	-	-	
30"	762	31 1/2"	800	122	55	Q1830V76A-4D	130	59	Q2130V76A-4D	142	64	Q2430V76A-4D	172	78	Q3030V76A-4D
36"	914	37 1/2"	953	129	59	Q1836V76A-4D	139	63	Q2136V76A-4D	153	69	Q2436V76A-4D	181	82	Q3036V76A-4D
42"	1067	43 1/2"	1105	143	65	Q1842V76A-4D	150	68	Q2142V76A-4D	166	75	Q2442V76A-4D	198	90	Q3042V76A-4D
48"	1219	49 1/2"	1257	147	67	Q1848V76A-4D	157	71	Q2148V76A-4D	170	77	Q2448V76A-4D	205	93	Q3048V76A-4D
54"	1372	55 1/2"	1410	162	73	Q1854V76A-4D	170	77	Q2154V76A-4D	187	85	Q2454V76A-4D	218	99	Q3054V76A-4D
60"	1524	61 1/2"	1562	169	77	Q1860V76A-4D	177	80	Q2160V76A-4D	194	88	Q2460V76A-4D	225	102	Q3060V76A-4D
66"	1676	67 1/2"	1715	185	84	Q1866V76A-4D	196	89	Q2166V76A-4D	212	96	Q2466V76A-4D	245	111	Q3066V76A-4D
72"	1829	73 1/2"	1867	187	85	Q1872V76A-4D	207	94	Q2172V76A-4D	220	100	Q2472V76A-4D	253	115	Q3072V76A-4D
<b>Units with Valu-Gard® Green Epoxy Coated Shelves</b>															
24"	610	25 1/2"	648	114	52	Q1824VG76A-4D	125	57	Q2124VG76A-4D	131	59	Q2424VG76A-4D	-	-	
30"	762	31 1/2"	800	122	55	Q1830VG76A-4D	130	59	Q2130VG76A-4D	142	64	Q2430VG76A-4D	172	78	Q3030VG76A-4D
36"	914	37 1/2"	953	129	59	Q1836VG76A-4D	139	63	Q2136VG76A-4D	153	69	Q2436VG76A-4D	181	82	Q3036VG76A-4D
42"	1067	43 1/2"	1105	143	65	Q1842VG76A-4D	150	68	Q2142VG76A-4D	166	75	Q2442VG76A-4D	198	90	Q3042VG76A-4D
48"	1219	49 1/2"	1257	147	67	Q1848VG76A-4D	157	71	Q2148VG76A-4D	170	77	Q2448VG76A-4D	205	93	Q3048VG76A-4D
54"	1372	55 1/2"	1410	162	73	Q1854VG76A-4D	170	77	Q2154VG76A-4D	187	85	Q2454VG76A-4D	218	99	Q3054VG76A-4D
60"	1524	61 1/2"	1562	169	77	Q1860VG76A-4D	177	80	Q2160VG76A-4D	194	88	Q2460VG76A-4D	225	102	Q3060VG76A-4D
66"	1676	67 1/2"	1715	185	84	Q1866VG76A-4D	196	89	Q2166VG76A-4D	212	96	Q2466VG76A-4D	245	111	Q3066VG76A-4D
72"	1829	73 1/2"	1867	187	85	Q1872VG76A-4D	207	94	Q2172VG76A-4D	220	100	Q2472VG76A-4D	253	115	Q3072VG76A-4D

\* For unit width, add 5 inches to shelf width.

\*\* Dimensions are nominal.

**EAGLE GROUP**

100 Industrial Boulevard, Clayton, DE 19938-8903 USA  
 Phone: 302-653-3000 or 800-441-8440 • Fax: 302-653-2065  
 www.eaglegrp.com • www.eaglehmc.com

Printed in U.S.A.  
 ©2022 by Eagle Group  
 Rev. 04/22

Spec sheets available for viewing, printing or downloading from our online literature library at [www.eaglegrp.com](http://www.eaglegrp.com)

Although every attempt has been made to ensure the accuracy of the information provided, we cannot be held responsible for typographical or printing errors. Information and specifications are subject to change without notice. Please confirm at time of order.