



Project _____
 Item # _____
 Quantity _____

SPECTRUM Planetary Mixers

Models: EMP-10, EMP-20, EMP-30

Commercial countertop and floor planetary mixers feature gear-driven motors with three speeds, making it an ideal piece of equipment for bakeries, delis, cafés, and other commercial kitchen environments.

Standard Features

- ◆ Three sizes available: 10.5QT (10L), 21.1QT (20L), 31.7QT (30L)
- ◆ Heavy-duty die cast iron construction
- ◆ Gear-driven, high torque transmission
- ◆ Large capacity 304 stainless steel bowl with safety guard and interlock bowl lift
- ◆ (3) three fixed mixing speeds
- ◆ Manual resettable thermal overload protection
- ◆ Industry standard #12 attachment hub (EMP-20 & EMP-30)
- ◆ Wire whip, aluminum flat beater, & spiral dough hook attachments included
- ◆ Non-slip rubber feet
- ◆ One year parts and labor warranty



EMP-10

EMP-20

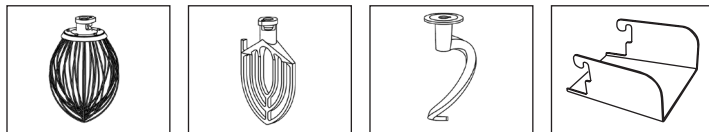

Accessories and Options

EMP-P7	10qt (304 series) Stainless Steel Bowl
EMP-P4	10qt Stainless Steel Wire Whip
EMP-P2	10qt Aluminum Flat Beater
EMP-P3	10qt Aluminum Spiral Dough Hook
EMP-P34	20qt (304 series) Stainless Steel Bowl
EMP-P27	20qt Stainless Steel Wire Whip
EMP-P29	20qt Aluminum Flat Beater
EMP-P28	20qt Aluminum Spiral Dough Hook
EMP-P58	30qt (304 series) Stainless Steel Bowl
EMP-P52	30qt Stainless Steel Wire Whip
EMP-P51	30qt Aluminum Flat Beater
EMP-P50	30qt Aluminum Spiral Dough Hook
EMP-IC	Ingredient Chute (EMP-20 & EMP-30)



EMP-30



For California Customers
WARNING: Cancer and Reproductive Harm - www.P65Warnings.ca.gov

Winco®, DWL International Trading, LLC

Headquarters
 65 Industrial Road, Lodi, NJ 07644
 Phone: 1-888-946-2682 | Fax: 1-973-916-9959

www.wincous.com | equipsales@wincous.com

Showroom
 10800 NW 103rd St. Bldg 22, Ste 11, Miami, FL 33178
 Phone: 1-786-536-4656 | Fax: 1-973-916-9959



Planetary Mixers

Models: EMP-10, EMP-20, & EMP-30

Model: EMP-10

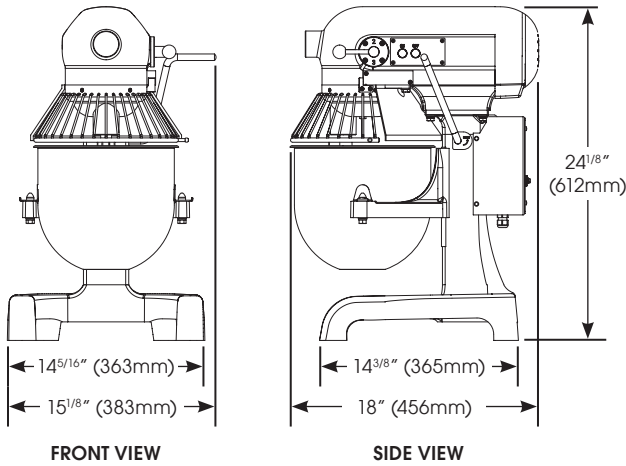

Model: EMP-20

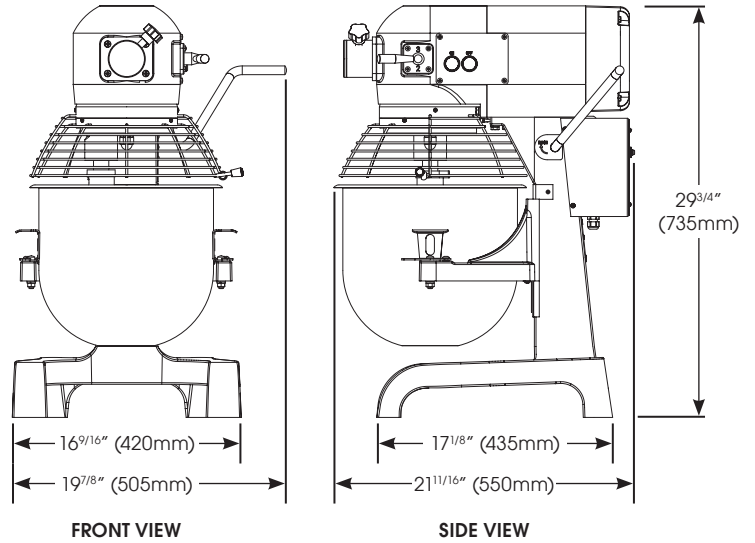

Model: EMP-30

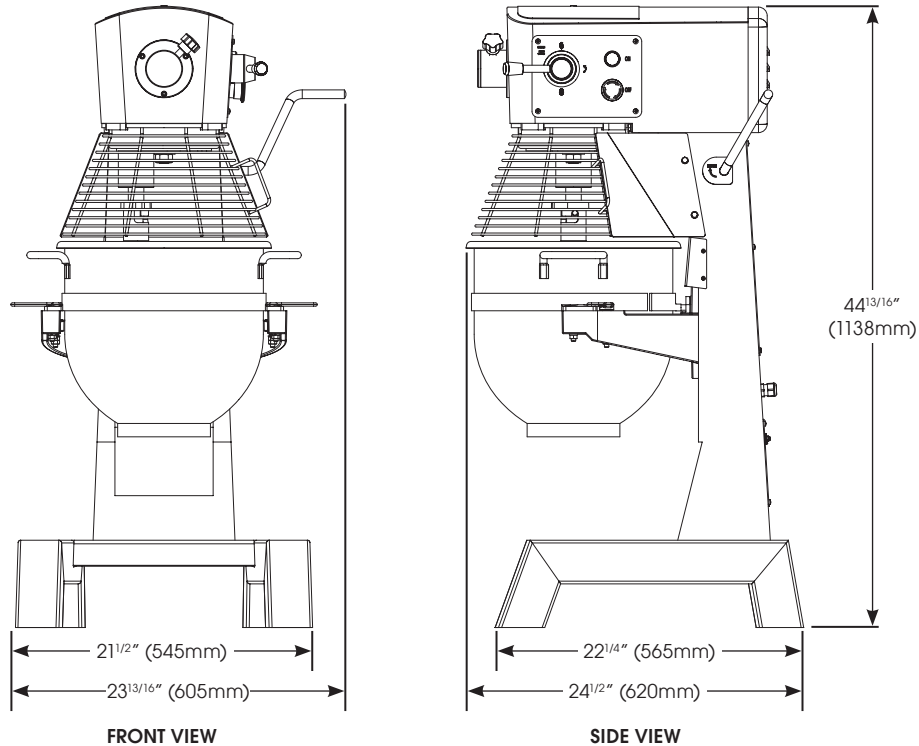

Winco®, DWL International Trading, LLC

www.wincous.com | equipsales@wincous.com

Headquarters
65 Industrial Road, Lodi, NJ 07644
Phone: 1-888-946-2682 | Fax: 1-973-916-9959

Showroom
10800 NW 103rd St. Bldg 22, Ste 11, Miami, FL 33178
Phone: 1-786-536-4656 | Fax: 1-973-916-9959



Planetary Mixers
Models: EMP-10, EMP-20, & EMP-30

MODEL	DESCRIPTION	OVERALL DIMENSIONS			VOLTS	HZ	WATTS	AMPS	PLUG	SHIP WEIGHT
		LENGTH	DEPTH	HEIGHT						
EMP-10	10.5 QT (10L)	15-1/8" (383mm)	18" (456mm)	24-1/8" (612mm)	110	50/60	750W 1HP	7A	NEMA 5-15P	99.2 lbs 45 kgs
EMP-20	21.1 QT (20L)	19-7/8" (505mm)	21-11/16" (550mm)	29-3/4" (735mm)	110	50/60	1100W 1.5HP	10A	NEMA 5-15P	233.7 lbs 106 kgs
EMP-30	31.7 QT (30L)	23-13/16" (605mm)	24-1/2" (620mm)	44-13/16" (1138mm)	110	50/60	1500W 2HP	14A	NEMA 5-15P	392.4 lbs 178 kgs

Plug Configurations

NEMA 5-15P

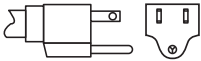

Cord Location

Back of unit

Product Specs

Planetary Mixers

The Planetary Mixers models EMP-10, EMP-20, and EMP-30 as manufactured by Winco®, Lodi, NJ 07644

The Planetary Mixer model EMP-10 shall have a 10.5 Qt (10L) capacity be rated at 750W 1HP, 110V-50/60Hz, model EMP-20 shall have a 21.1 Qt (20L) capacity be rated at 1100W 1.5HP, 110V-50/60Hz, and model EMP-30 shall have a 31.7 Qt (30L) capacity be rated at 1500W 2HP, 110V-50/60Hz. All units shall be supplied with a NEMA 5-15P plug.

Units shall be constructed of heavy-duty die cast iron construction and be equipped with gear-driven, high torque transmission, large capacity 304 stainless steel bowl with interlock bowl lift, (3) three fixed mixing speeds, manual resettable thermal overload protection, stainless steel bowl guard with interlock, industry standard #12 attachment hub (EMP-20 & EMP-30), wire whip, aluminum flat beater, & spiral dough hook attachments included, and non-slip rubber feet.

CE certified and ETL listed for safety (Canada & US) and sanitation.

Warranty consists of one year parts and labor.

Winco®, DWL International Trading, LLC

www.wincous.com | equipsales@wincous.com

Headquarters

65 Industrial Road, Lodi, NJ 07644
 Phone: 1-888-946-2682 | Fax: 1-973-916-9959

Showroom

10800 NW 103rd St. Bldg 22, Ste 11, Miami, FL 33178
 Phone: 1-786-536-4656 | Fax: 1-973-916-9959