



Model: _____ Item #: _____ Date: _____

Project: _____ Qty: _____ Approved By: _____

CO2/Nitrogen Dual Beverage Gas Blender

MASTERTAP

Standard Features

- Blend CO2 and Nitrogen gas on the premises
- Allows for perfect blend of gas for every pour
- Ability to change gas mixture
- Standard lager mixture; 55% CO2, 45% Nitrogen
- Standard stout mixture; 25% CO2, 75% Nitrogen

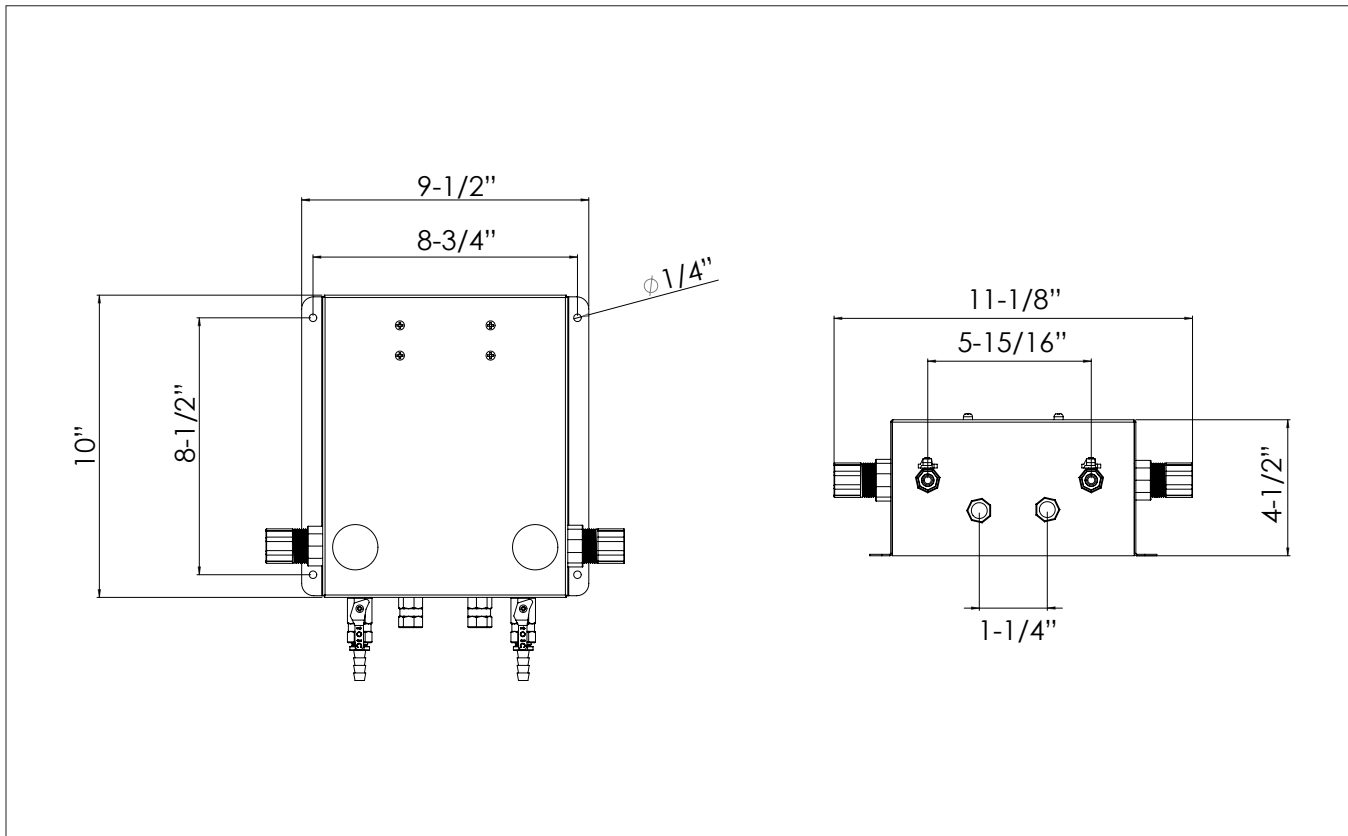

Krowne Metal Corporation • 100 Haul Rd. Wayne, NJ 07470 • P: (800) 631-0442 • customerservice@krowne.com • krowne.com

Due to our commitment to continued product improvement, specifications are subject to change without notice.

Rev. 6/2022 • KGBB-1D