

# "MBR-C" MEAT BOAT RACKS

## *Stainless Steel - Ceiling Mount*

**FEATURES:**

- 14GA Stainless Steel Construction
- Ceiling Mount
- Adjustable Height

**SPECIFICATIONS:**

- Ceiling Mounts: 1-1/4"x2" Square Stainless Steel Angle With #4 Polish, Satin Finish
- Wire Cage: Type 300, Electro Polished, 2" Square Wire Mesh

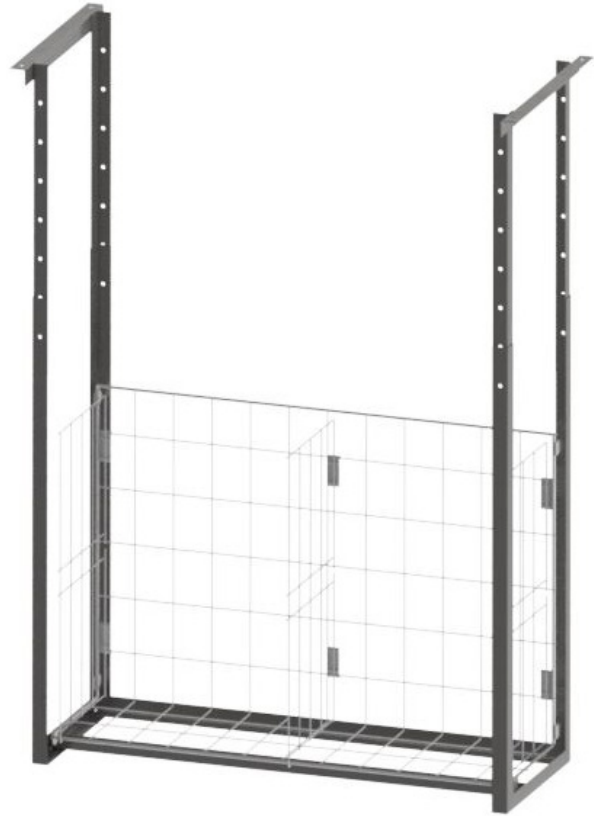

### ACCESSORIES

MODEL	DESCRIPTION
MPH01	Stainless Steel Paper Holder
MBR14	Stainless Steel Dividers

### "MBR-C" MEAT BOAT RACKS

MODEL	SIZE (L X W X H)	WEIGHT (LBS)
MBR15A	36"x12"x25"	28
MBR15	48"x12"x25"	37
MBR16A	60"x12"x25"	46
MBR16	72"x12"x25"	54
MBR17A	84"x12"x25"	63
MBR17	96"x12"x25"	71

ALL DIMENSIONS ARE TYPICAL. TOLERANCE +/- .500". JOHN BOOS & CO. RESERVES THE RIGHT TO CHANGE SPECIFICATIONS WITHOUT NOTICE.

# DETAILED SPECIFICATIONS

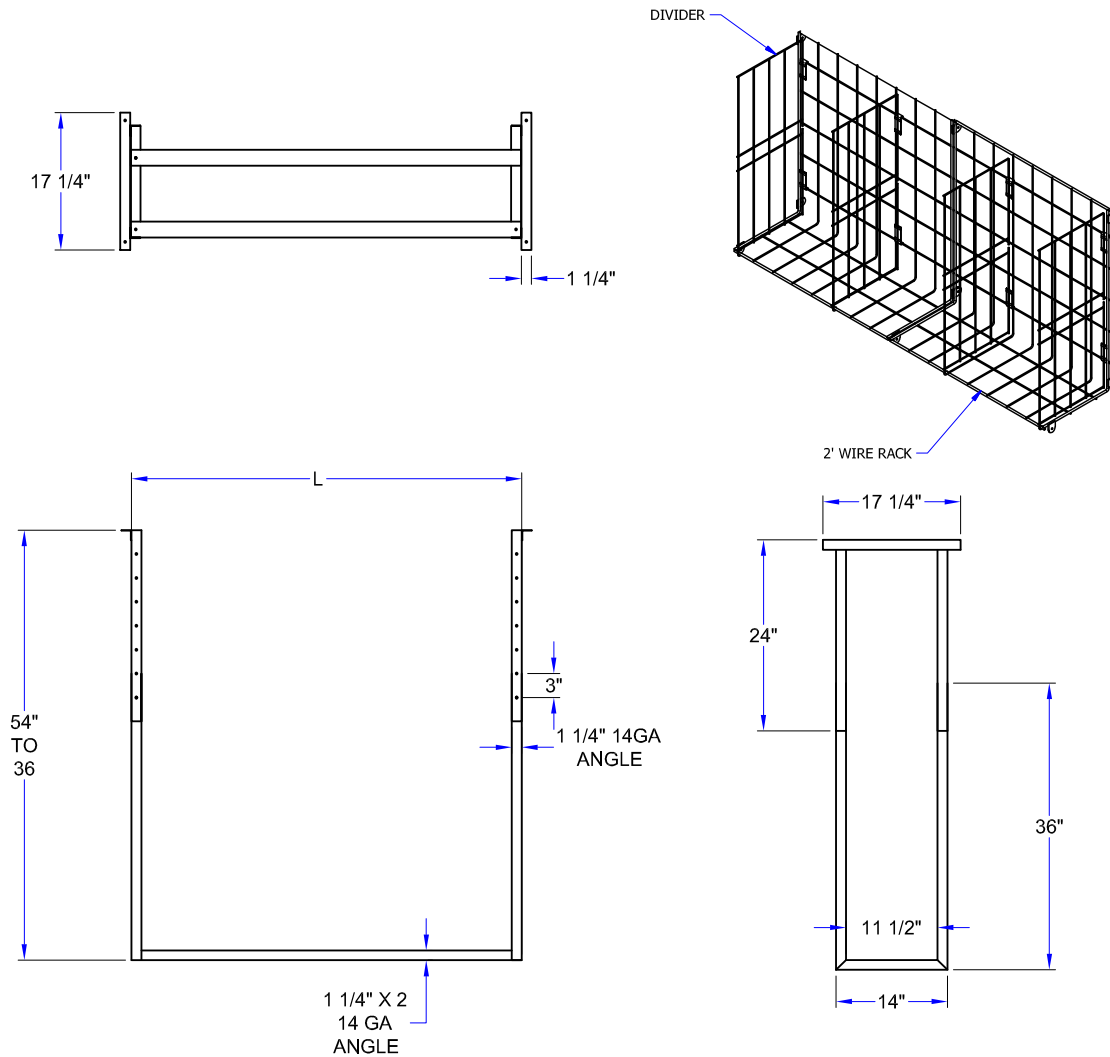

## "MBR-C" MEAT BOAT RACKS

MODEL	SIZE (L X W X H)	WEIGHT (LBS)
MBR15A	36"x12"x25"	28
MBR15	48"x12"x25"	37
MBR16A	60"x12"x25"	46
MBR16	72"x12"x25"	54
MBR17A	84"x12"x25"	63
MBR17	96"x12"x25"	71

ALL DIMENSIONS ARE TYPICAL. TOLERANCE +/- .500". JOHN BOOS & CO. RESERVES THE RIGHT TO CHANGE SPECIFICATIONS WITHOUT NOTICE.