



LEGEND™ Heavy-Duty Freezer Equipment Bases

Item No. _____

Project _____

Quantity _____



Model FB-72-SC Shown with optional casters and Marine edge

SHORT/BID SPECIFICATION

Counter-top equipment to be mounted to a Montague Legend Refrigerated-Freezer Chef Base:

- FB-___** [Specify width: 36" (914mm), 48" (1219mm), 60" (1524mm), 72" (1829mm), 84" (2134mm), 96" (2438mm) or 108" (2743mm)]
 - **___** [Specify: **R** = Remote Freezer (condensing unit by others) or **SC** = Self Contained Freezer Package]

...heavy-duty low ergonomic-height low profile freezer designed to support heavy countertop cooking equipment with integrated transition base, 304 Stainless steel front, sides, top, bottom and back, Digital Thermometer, Turbo Coil powered evaporator coil, Heavy-duty, full extension ventilated drawer system, with 2" (51mm) thick foamed in place, environmentally friendly, Non GWP, Non ODP, Kyoto Protocol compliant, polyurethane foam and 6" (152mm) high stainless steel height-adjustable legs standard; plus all the features listed and options/accessories checked:

FREEZER PACKAGE FEATURES:

- SC Self-Contained Models:**
- Energy efficient hermetic compressor/condenser system
 - Hot Gas Condensate System
 - Coated evaporator coil by Turbo-Coil
 - Digital thermostat temperature control
 - 6' (1829mm) power cord with grounded NEMA plug (consult factory for type)
 - Compressor compartment on right end
 - Condenser coil screen
 - Electric Defrost
 - Three year standard parts and labor warranty
 - Five year parts and labor warranty on Compressor
 - Five year parts and labor warranty on Turbo-Coil coated evaporated coil
- R Remote Models**
- Fully assembled evaporator coil, expansion valve, solenoid, and thermostat
 - Coated evaporator coil by Turbo-Coil
 - Digital thermostat temperature control.
 - 6" (153mm) power leads with field access junction box
 - Electric Defrost
 - Three-year standard parts and labor warranty.
 - Five year parts and labor warranty on Turbo-Coil coated evaporated coil
 - Refrigeration, drain line and electric connection will be stubbed out as specified: **LE** left-end, **RE** right-end, **BL** back-left, **BR** back-right

Self-Contained Freezer MODEL GUIDE

Model Number	Unit Width Inches (mm)	Drawers: Width & No.			Total Full Pans
		14-3/8" (356mm)	22-3/8" (568mm)	27-1/4" (692mm)	
FB-36-SC	36" (914)	2			2
FB-48-SC	48" (1219)			2	4
FB-60-SC	60" (1524)	2	2		6
FB-72-SC	72" (1829)		2	2	8
FB-84-SC	84" (2134)			4	8
FB-96-SC	96" (2438)		4	2	12
FB-108-SC	108" (2743)			6	12

Remote Freezer MODEL GUIDE

Model Number	Unit Width Inches (mm)	Drawers: Width & No.			Total Full Pans
		14-3/8" (356mm)	22-3/8" (568mm)	27-1/4" (692mm)	
FB-36-R	36" (914)			2	4
FB-48-R	48" (1219)	2	2		6
FB-60-R	60" (1524)		2	2	8
FB-72-R	72" (1829)			4	8
FB-84-R	84" (2134)		4	2	12
FB-96-R	96" (2438)			6	12
FB-108-R	108" (2743)		6	2	16

HEAVY-DUTY DRAWER SYSTEM FEATURES:

- Full extension, 250 lbs (45 kg) individual drawer weight capacity
- Accommodates 4" (102mm) deep, 12" x 20" (305 x 508mm) pans
- Heavy 14-gauge stainless steel track system
- Tandem 2" (51mm) diameter stainless steel wheels
- Full Length recessed drawer handles
- Self closing drawers are easily removed for cleaning
- Removable/ replaceable magnetic drawer gaskets
- Lifetime warranty on drawer slides

STANDARD BASE CONSTRUCTION:

- Low profile for ergonomic countertop equipment work height
- All welded construction
- 304 Stainless steel front, top & sides, back & bottom
- Digital thermometer
- Interior liner is stainless steel with 1/4" (6mm) radius corners
- 2" (51mm) thick environmentally friendly, Non Ozone Depletion Potential, Non Global Warming Potential, high density polyurethane foam insulation
- 6" (152mm) height-adjustable stainless steel legs standard

AGENCY APPROVALS

- UL Classified EPH-STD NSF-7
- UL Listed



RF-2 [Rev. 3/17]

LEGEND™ Heavy-Duty Refrigerated Freezer Chef Bases

Item No. _____

Project _____

Quantity _____

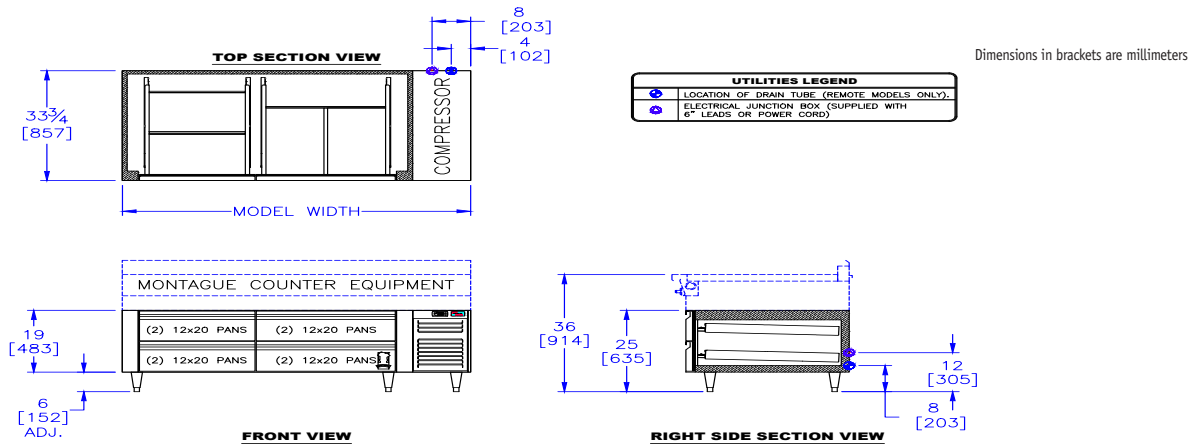

OPTIONS GUIDE:

- 6" (152mm) diameter casters [4-8 depending on width]
- Curb mounting [Consult Factory]
- Stainless steel top with marine edge

Custom Options (Consult Factory):

- Custom sizes & configurations
- Compressor compartment on left
- Drawer padlocking
- Fixed Gaskets

Remote Refrigerants:

- 134A
- 404A

INSTALLATION REQUIREMENTS & SHIPPING INFORMATION

- Montague freezer bases are designed and sized for use with Montague Legend Heavy-Duty Countertop cooking equipment. [See Legend Countertop Specification Sheets.]
- Follow installation, ventilation and wall clearance requirements for the countertop cooking equipment mounted on the freezer base.
- Unit to be leveled and plumbed at installation for proper drain function

Minimum Clearances	Always follow clearances of top mounted equipment
From Back Wall	2" (51mm)
Right Side -SC Models	0"***

***Consult factory for custom installations and specific model configurations

Electrical Requirements								Shipping Weight	Shipping Class	Cube (Crated) ft3/m3
Model:	Width Inches (mm)	HP*	Voltage	Phase	Amps	NEMA Plug	BTU's			
FB-36-R	36" (914)	—	115	1	3.95	N/A	3120	350 lbs (159 kg)	85	13/4
FB-48-R	48" (1219)	—	115	1	7.05	N/A	3660	400 lbs (181 kg)	85	18/5
FB-60-R	60" (1524)	—	115	1	7.91	N/A	4020	450 lbs (204 kg)	85	23/7
FB-72-R	72" (1829)	—	115	1	8.26	N/A	4560	500 lbs (227 kg)	85	27/8
FB-84-R	84" (2134)	—	115	1	9.10	N/A	5100	550 lbs (249 kg)	85	32/9
FB-96-R	96" (2438)	—	115	1	12.09	N/A	5640	600 lbs (272 kg)	85	36/1
FB-108-R	108" (2743)	—	115	1	15.17	N/A	6175	780 lbs (354 kg)	85	41/1.1
FB-36-SC	36" (914)	1/3	115	1	9.3	5-15P	2580	470 lbs (213 kg)	85	13/4
FB-48-SC	48" (1219)	1/3	115	1	9.3	5-15P	3120	495 lbs (225 kg)	85	18/5
FB-60-SC	60" (1524)	1/2	115	1	15.77	5-20P	3660	525 lbs (238 kg)	85	23/7
FB-72-SC	72" (1829)	3/4	115	1	14.98	5-20P	4020	550 lbs (249 kg)	85	27/8
FB-84-SC	84" (2134)	3/4	115	1	15.34	5-20P	4560	625 lbs (283 kg)	85	32/9
FB-96-SC	96" (2438)	1	115	1	22.57	5-20P	5100	700 lbs (317 kg)	85	36/1
FB-108-SC	108" (2743)	1	115	1	23.15	5-20P	5640	875 lbs (397 kg)	85	41/1.1

*HP = Motor Horsepower

Due to continuous product improvements, specifications are subject to change without notice.



THE MONTAGUE COMPANY

1830 Stearman Avenue, Hayward, CA 94545
 800 345-1830 · Fax: 510 785-3342
 www.montaguecompany.com

