

## Special Features:

- ✓ Heated Holding / Proofing Cabinet
- ✓ Half Height / Undercounter Model
- ✓ Sturdy Aluminum Construction
- ✓ Exterior Color: Silver
- ✓ (12) 18" x 26" pan capacity
- ✓ This Model is Insulated to Preserve Internal Temperature
- ✓ Manual Heat and Humidity Controls
- ✓ Single Door, Single Section Unit
- ✓ Clear Door Allows Operators to See Cabinet Contents
- ✓ Easy to Use Lip Load Slides Hold Pans Securely
- ✓ Power type: Electric
- ✓ Plug Type: NEMA 5-15P
- ✓ Stands on (4) 5" Casters, Front 2 Casters Lock to Prevent Unintentional Movement
- ✓ Certifications: NSF & UL Listed

## Product Description:

The Empura E-HPI1812 is a half height holding / proofing cabinet with a sturdy and elegant aluminum construction, (12) 18" x 26" pan capacity, and manual temperature controls. This holding / proofing cabinet features energy efficient insulation and the clear door allows the operator to view the contents. This model stands on 5" casters, the front two of which have locks to help prevent unintentional movement and keep the unit steady.

**Intended For Commercial Use Only.** Empura assumes no liability for component failure, factory defects or any other damages for units installed in non-commercial foodservice or residential applications.

## About Empura Holding / Proofing Cabinets:

Empura Holding / Proofing Cabinets are an economical choice when you are looking to update or expand your kitchen's heated holding and dough proofing capacity. Sturdy aluminum construction, cabinet insulation, and high pan capacities make these cabinets a dependable option for business owners. You can count on the Empura Holding / Proofing Cabinets to proof dough perfectly and keep food at the proper temperature for safe serving.



## TECHNICAL SPECS

### Dimensions & Construction

Overall Width	23-1/8"
Overall Depth	33-3/16"
Overall Height	30-5/8"
18" x 26" Pan Capacity	12 Pans
Cabinet Size	Half Size
Construction Material	Aluminum
Number of Doors	1
Door Type	Clear
Dutch Half Door	No
Insulation	Yes
Casters	5" (Front 2 Lock)
Sections	1
Interior Configuration	Lip Load Slides

### Heating & Electrical

Power Type	Electric
Control Type	Manual
Temperature Range	80°F - 185°F
Plug Type	NEMA 5-15P
Amps	12
Hertz	60
Phase	1
Voltage	120
Wattage	1,440
Humidity Control	Yes

## UNIT VIEW

### Front Angled View

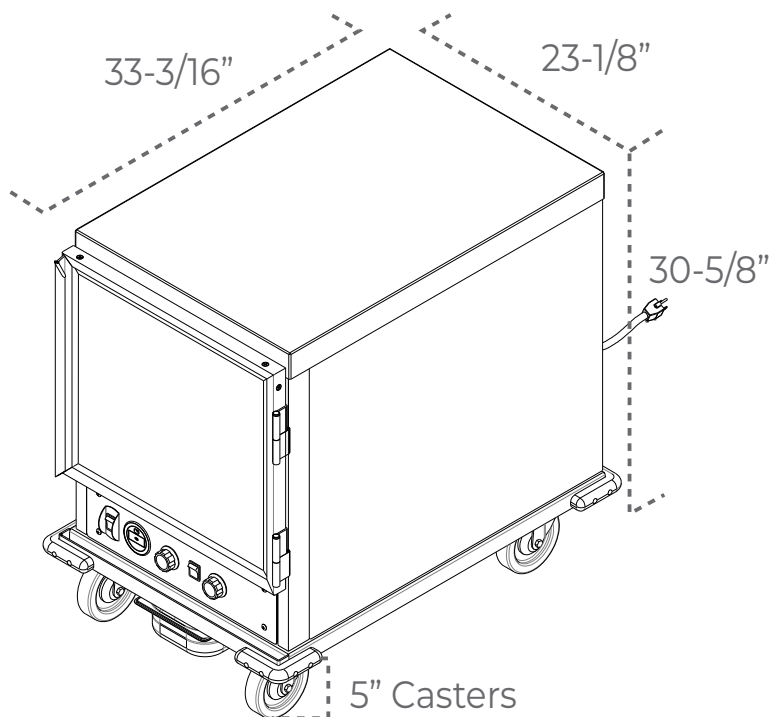

**Attention CA Residents:** This product can expose you to chemicals including lead, which are known to the State of California to cause cancer, birth defects, or other reproductive harm. For more information, go to [www.p65warnings.ca.gov](http://www.p65warnings.ca.gov).



**NEMA 5-15P Plug:**  
This unit comes with a NEMA 5-15P plug