

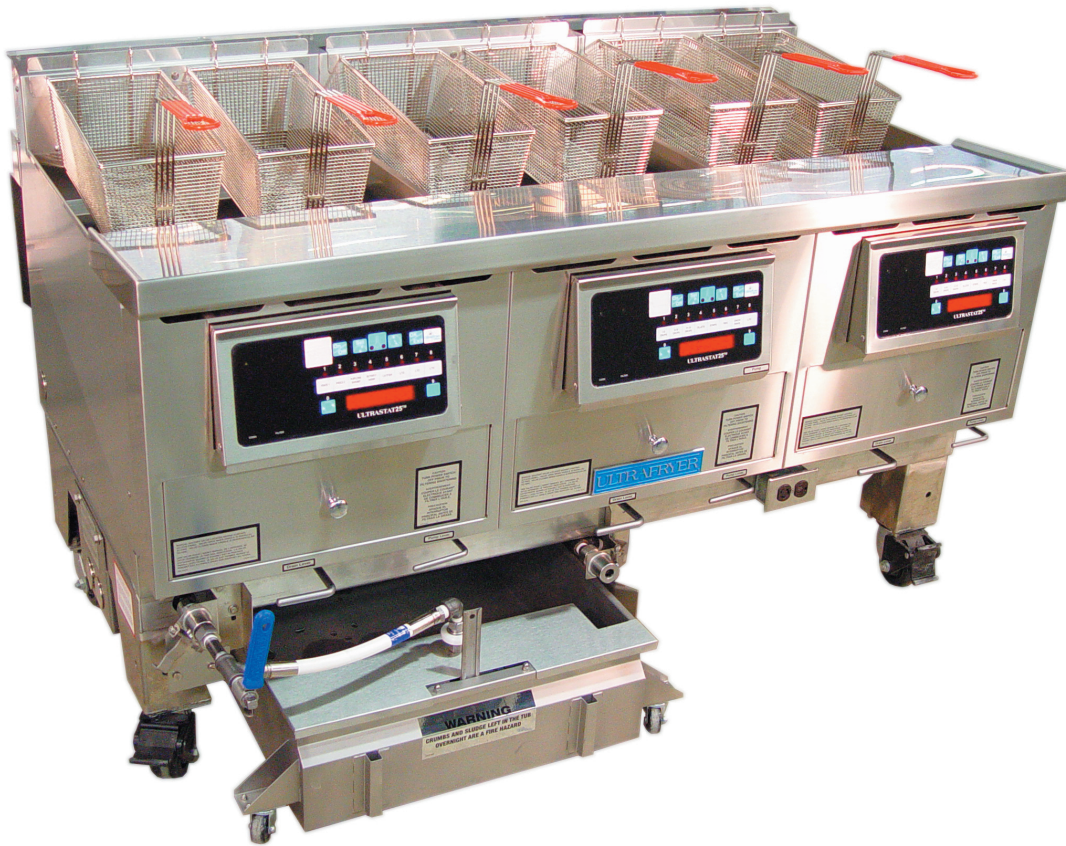

## Model B-P30- 14/18/20 Gas Fryer Operation Instructions



**Ultrafryer Systems**  
**302 Spencer Lane**  
**P.O. Box 5369**  
**San Antonio, TX 78201**

**Local: (210) 731-5000**  
**Toll-Free: (800) 525-8130**  
**Fax: (210) 731-5099**  
**Web: [www.ultrafryer.com](http://www.ultrafryer.com)**



---

# Contents

PREFACE .....

GENERAL INFORMATION .....

    WARRANTY .....

    SAFETY .....

RECEIVING AND INSTALLING .....

INITIAL STARTUP .....

DEFAULT-TO-MANUAL-RESTART (DTMR) .....

ULTRASTAT U25 COOK COMPUTER .....

    ULTRASTAT 25 COMPUTER with SMS FEATURES .....

FILTER TUB ASSEMBLY & INSTALLATION .....

SHORTENING FILTRATION PROCEDURES .....

CLEANING .....

PREVENTIVE MAINTENANCE & TROUBLESHOOTING .....

ELECTRONIC THERMOSTAT CALIBRATION .....

TECHNICAL ASSISTANCE & PARTS ORDERING INFORMATION .....

RECOMMENDED SPARE PARTS .....

Model 2005 Gas Fryer Component Parts List .....

*ELECTRICAL DIAGRAM*

## PREFACE

This Manual was written and published by the Engineering Department, Ultrafryer Systems for use by personnel who will operate a Model 2005 fryer in a commercial cooking environment.

### **THIS APPLIANCE IS INTENDED FOR PROFESSIONAL USE AND IS TO BE OPERATING BY QUALIFIED PERSONNEL**

Throughout this manual Notes, **CAUTIONS** and **WARNINGS** are used to alert the operator to items of special circumstances. These items are identified as follows:

**NOTE:** Pull on the filter tub to ASSURE the male docking plug is SEATED in the female bulkhead socket.

**CAUTION:** TO ASSURE PRODUCING A QUALITY PRODUCT WHILE PROLONGING THE LIFE EXPECTANCY OF THE FRYER, ENSURE FILTERING, BOIL-OUT AND CLEANING INSTRUCTIONS ARE STRICTLY ADHERED TO.

**WARNING: DO NOT ALLOW ANY CLEANING SOLUTION OR WATER TO SPLASH INTO A VESSEL OF HOT COOKING OIL, AS IT WILL CONTAMINATE THE OIL AND MAY CAUSE THE OIL TO SPLATTER CAUSING SEVERE BURNS.**

*This manual is intended as a guide for all model PNP fryers, regardless of configuration, filtration options and controllers. It is to be used in conjunction with the applicable controller manual that is included with the fryer.*

# General Information

## ULTRAFRYER<sup>®</sup> LIMITED WARRANTY: PAR-3 GAS, ELECTRIC

Ultrafryer Systems warrants to the original purchaser of a gas or electric Ultrafryer<sup>®</sup> sold within the United States, its territories and Canada, that it will be free of defects in material and workmanship for the periods listed below:

**STAINLESS STEEL FRYER VAT** – Stainless Steel fryer vats are warranted for (10) ten years upon the terms hereinafter described. The (10) ten year warranty coverage applies **ONLY** to the Stainless Steel fryer vat and does not apply to the other components such as controls, fire boxes, gaskets, mounting hardware, or the heat shield weldment. The (10) ten year limited warranty coverage for the Stainless Steel fryer vats are as follows: (1) Vats that fail due to faulty workmanship or materials within the first twelve (12) months from the date of initial start up will be exchanged at no cost. Standard delivery ground freight will be prepaid by Ultrafryer Systems **for first year failures only**. The cost of labor to install the replacement vat will be covered by Ultrafryer Systems for vats, which fail within twelve (12) months from the date of initial start up. Labor for vat replacements after the first year is the responsibility of the owner (2) Vats that fail within the second through fifth year will be exchanged at \$250.00 FOB San Antonio. (3) Vats that fail within the sixth through eighth year will be exchanged at 50% of current selling price of said vat FOB San Antonio. (4) Vats that fail within the ninth through tenth year will be exchanged at 70% of the current selling price of said vat FOB San Antonio. **(Example:** If the current selling price for a particular vat is \$2,000.00, then a failure during the sixth through eighth year would be exchanged for \$1,000.00; if the failure occurred in the ninth or tenth year it would be exchanged for \$1,400.00.) Proper credit issue for vat failures is contingent upon receipt, by Ultrafryer Systems, of the serial number identification tag for any failed vat.

**ULTRAFRYER PARTS** – All parts on the Ultrafryer<sup>®</sup> are covered for a period of one (1) year from the initial date of start up. This is to include gas valves, switches, thermostats, etc. Ultrafryer Systems reserves the right to charge for certain parts such as computers, filter pumps and motors or any item over the amount of \$100.00 until Ultrafryer Systems receives the defective part back. **After inspection, credit for the part will be issued to the purchaser provided the part is deemed defective and that defect is not the result of neglect or abuse by the user.** The shortening filtration system, (hoses) are warranted for ninety (90) days from the initial date of start up.

**PROCESSING WARRANTY CLAIMS** – The equipment owner must promptly notify Ultrafryer Systems Warranty Department of any alleged defects as soon as they are discovered by calling 1-800-525-8130. After such notice, the Warranty Department will perform its obligation under this warranty within a commercially reasonable period of time. If alleged defects develop after normal business hours, on weekends or on holidays the owner must call Ultrafryer Systems first at the above number. This number is monitored 24 hours a day, 7 days a week. Ultrafryer Systems will notify an authorized service agent to make repairs during normal hours or after hours. Any parts that need to be shipped back to Ultrafryer Systems will be shipped back **prepaid by the customer** marked with the processing number and to the attention of the WARRANTY DEPARTMENT.



**NON WARRANTY COVERAGE** – This warranty does not include coverage for any consequential cost of damages including, but not limited to, any loss in store sales, spoiled food products, transportation, duty or custom cost. This warranty does not cover the Ultrafryer® exported to countries outside the United States and its territories. This warranty does not cover original installation and adjustments such as leveling, calibrations and electrical and gas connections. This warranty does not cover travel over 100 miles or 2 hours driving time from the location of the Ultrafryer® or overtime or holiday charges unless the Warranty Department granted prior approval. This warranty does not cover damage due to misuse, abuse, alteration or accident. This Warranty does not cover improper or unauthorized repair or installation, damage in shipment, normal maintenance items such as gaskets, hoses, and exterior finishes. Ultrafryer Systems will begin the fryer warranty one week after shipment but will adjust the warranty upon receiving approved documentation. We reserve the right to void component part warranty on any Ultrafryer that is stored more than six (6) months after shipment from Ultrafryer Systems and not put into service.

**LABOR COVERAGE** – The cost for labor to replace parts are covered for one (1) year after the initial start up. **The Warranty Department must be promptly notified of any defects within the first year of operation.** The labor warranty does not include the cost to repair or clear dirty filter systems or perform any adjustments that would normally fall under the tasks associated with a proper start up and/or demonstration. **Labor is covered by Ultrafryer Systems for repairs by an AUTHORIZED service agent.** Owner is responsible for all costs associated with fryer installation and start up unless prior arrangements have been made with Ultrafryer Systems.

#### **DISCLAIMER OF WARRANTIES**

Other than as stated herein, ULTRAFRYER SYSTEMS makes no warranty of any kind, express or implied, including but not limited to any warranty of merchantability of fitness for a particular purpose, including trade usage. Ultrafryer Systems' sole obligation, and purchaser's sole remedy, under this warranty is repair or replacement, at the discretion of Ultrafryer Systems, of any part or component that proves to be defective in materials or workmanship. In no event shall Ultrafryer Systems be liable for consequential, incidental, or special loss or damages arising from the use of, or inability to use, the ULTRAFRYER®. This limited warranty is the only and complete statement with respect to warranties of NEW Ultrafryer® PAR-3 Gas and Electric ULTRAFRYERS® sold after June 1<sup>st</sup>, 2000. There are no other documents or oral statements for which Ultrafryer Systems will be responsible. Effective 2-1-2008.

## **ULTRAFRYER<sup>®</sup> LIMITED WARRANTY: CADET**

Ultrafryer Systems warrants to the original purchaser of a gas or electric Cadet sold within the United States that it will be free of defects in material and workmanship for the periods listed below:

**STAINLESS STEEL FRYER VAT** – Stainless Steel fryer vats are warranted for (8) eight years upon the terms hereinafter described. The (8) eight year warranty coverage applies ONLY to the Stainless Steel fryer vat and does not apply to the other components such as controls, fire boxes, gaskets, mounting hardware, heat exchanger baffles or the heat shield weldment. The (8) eight year limited warranty coverage for the Stainless Steel fryer vats are as follows: (1) Vats that fail due to faulty workmanship or materials within the first twelve (12) months from the date of initial start up will be exchanged at no cost. Standard delivery ground freight will be prepaid by Ultrafryer Systems **for first year failures only**. The cost of labor to install the replacement vat will be covered by Ultrafryer Systems for vats, which fail within twelve (12) months from the date of initial start up. Labor for vat replacements after the first year is the responsibility of the owner. (2) Vats that fail within the second through fourth year will be exchanged at \$350.00 FOB San Antonio. (3) Vats that fail within the fifth through sixth year will be exchanged at 60% of current selling price of said vat FOB San Antonio. (4) Vats that fail within the seventh through eighth year will be exchanged at 75% of the current selling price of said vat FOB San Antonio. (**Example:** If the current selling price for a particular vat is \$2,000.00, then a failure during the fifth through sixth year would be exchanged for \$1,200.00, etc.) Proper credit issue for vat failures is contingent upon receipt, by Ultrafryer Systems, of the vat and fryer serial number identification tag for any failed vat.

**ULTRAFRYER PARTS** – All parts on the Ultrafryer<sup>®</sup> are covered for a period of one (1) year from the initial date of start up. This is to include computers, gas valves, switches, thermostats, etc. Ultrafryer Systems reserves the right to charge for certain parts such as computers, filter pumps and motors or any item over the amount of \$100.00 until Ultrafryer Systems receives the defective part back. **After inspection, credit for the part will be issued to the purchaser provided the part is deemed defective and that defect is not the result of neglect or abuse by the user.** The shortening filtration system, (hoses) are warranted for ninety (90) days from the initial date of start up.

**PROCESSING WARRANTY CLAIMS** – The equipment owner must promptly notify Ultrafryer Systems Warranty Department of any alleged defects as soon as they are discovered by calling **1-800-525-8130**. After such notice, the Warranty Department will perform its obligation under this warranty within a commercially reasonable period of time. If alleged defects develop after normal business hours, on weekends or on holidays the owner must call Ultrafryer Systems first at the above number. This number is monitored 24 hours a day, 7 days a week. Ultrafryer Systems will notify an authorized service agent to make repairs during normal hours or after hours. Any parts that need to be shipped back to Ultrafryer Systems will be shipped back **prepaid by the customer** marked with the processing number and to the attention of the WARRANTY DEPARTMENT.

**NON WARRANTY COVERAGE** – This warranty does not include coverage for any consequential cost of damages including, but not limited to, any loss in store sales, spoiled food products, transportation, duty or custom cost. This warranty does not cover the Ultrafryer® exported to countries outside the United States and its territories. This warranty does not cover original installation and adjustments such as leveling, calibrations and electrical and gas connections. This warranty does not cover travel over 100 miles or 2 hours driving time from the location of the Ultrafryer® or overtime or holiday charges unless the Warranty Department granted prior approval. This warranty does not cover damage due to misuse, abuse, alteration or accident. This Warranty does not cover improper or unauthorized repair or installation, damage in shipment, normal maintenance items such as heat exchanger baffles, gaskets, hoses, and exterior finishes. Ultrafryer Systems will begin the fryer warranty one week after shipment but will adjust the warranty upon receiving approved documentation. We reserve the right to void component part warranty on any Ultrafryer that is stored more than six (6) months after shipment from Ultrafryer Systems and not put into service.

**LABOR COVERAGE** – The cost for labor to replace parts are covered for one (1) year after the initial start up. **The Warranty Department must be promptly notified of any defects within the first year of operation.** The labor warranty does not include the cost to repair or clear dirty filter systems or perform any adjustments that would normally fall under the tasks associated with a proper start up and/or demonstration. **Labor is covered by Ultrafryer Systems for repairs by an AUTHORIZED service agent.** Owner is responsible for all costs associated with fryer installation and start up unless prior arrangements have been made with Ultrafryer Systems.

#### **DISCLAIMER OF WARRANTIES**

Other than as stated herein, ULTRAFRYER SYSTEMS makes no warranty of any kind, express or implied, including but not limited to any warranty of merchantability of fitness for a particular purpose, including trade usage. Ultrafryer Systems' sole obligation, and purchaser's sole remedy, under this warranty is repair or replacement, at the discretion of Ultrafryer Systems, of any part or component that proves to be defective in materials or workmanship. In no event shall Ultrafryer Systems be liable for consequential, incidental, or special loss or damages arising from the use of, or inability to use, the Cadet. This limited warranty is the only and complete statement with respect to warranties of NEW CADET fryers. There are no other documents or oral statements for which Ultrafryer Systems will be responsible. Effective 2-1-2008.

# Safety

The major safety concern associated with the Ultrafryer Gas Fryer is burns from hot shortening. In order to prevent serious burns, good housekeeping habits are required. The floor in front of the fryer and the area around the fryer should be kept clean and dry. Whenever anything is placed into a fryer vat, care should be used not to splash the hot shortening. Product should always be “PLACED” into the shortening, NOT THROWN. Safety goggles, neoprene insulated gloves and an apron must be worn while filtering or boiling-out a fryer vat.

Electrical controls on all Ultrafryer Fryers operate on 120 volts single phase electrical power. No adjustments or replacement of electrical controls should ever be attempted without first disconnecting electrical power. The fryer should never be operated with wet hands or while standing in water. To do so can result in serious electrical shock or death.

## Automatic Safety Features

This fryer is equipped with the following Automatic Safety Features:

1. **High limit thermostat** to shut off gas to the main burners by opening a solenoid-actuated safety valve in the combination gas control valve if shortening temperature **exceeds** 400°F (204°C).
2. **Combination gas control valve** which includes a built-in pressure regulator and manual valve.
3. **Sensor circuit** within the spark ignitor module to turn gas to the fryer **OFF** if a burner **flameout** occurs.
4. A **Drain Valve Safety Switch** and a **Default-to-Off circuit** in the Default-to-Manual-Restart (DTMR) Control that will **disable** the fryer each time the drain valve is **opened**.
5. PAR-2-FL Fryers have a **centrifugal** switch whereas PAR-3-FL fryers have an **air pressure** switch to open the electrical circuit to the spark ignitor and gas valve, which will turn the gas to the fryer **OFF** in the event the blower fails.

## Optional Accessories

This gas fryer may also be equipped with an Automatic Basket Lift System. If equipped, please refer to either one of the following:

- UFS Manual P/N 30A081, SKF Motion Technologies, Inc. Automatic Basket Lift Operating Instructions, or
- UFS Manual P/N 30A155, UFS Automatic Basket Lift Operating Instructions.

The applicable manual will be included with the fryer.

**Note:** The procedures contained herein are applicable to the default-to-manual restart (DTMR) controller. If a fryer is equipped with an optional cook computer, its manual will be included with the fryer. The following list describes the optional cook computers and their applicable manuals:

Ultrastat 25 Cooking Computer (refer to Manual P/N 30A051)

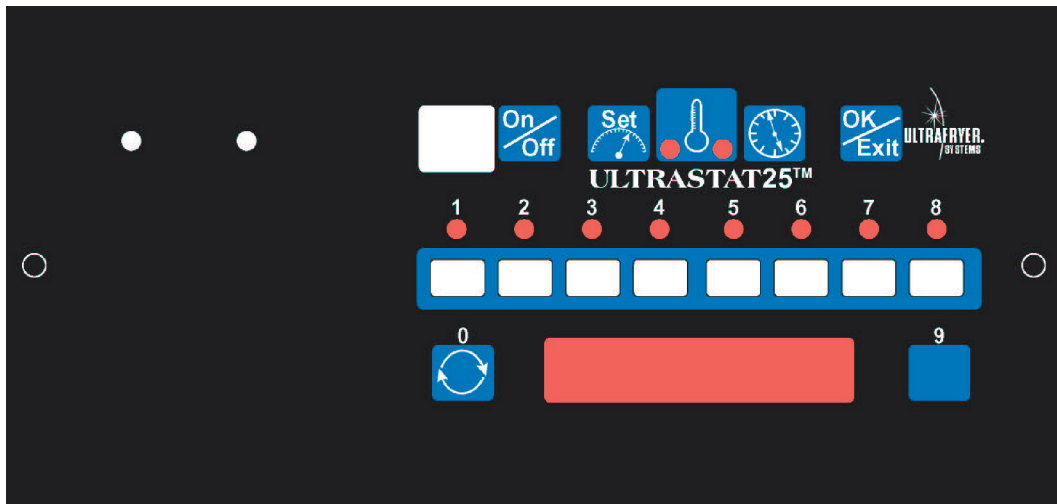

Ultrastat 21 Cooking Computer (refer to Manual P/N 30A009)

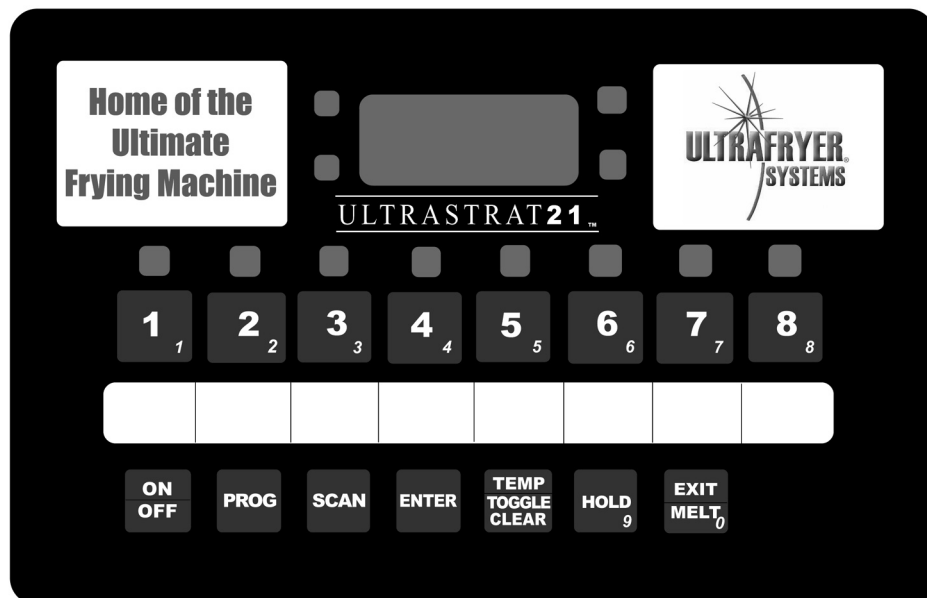

Ultrastat 11 Cooking Computer (refer to Manual P/N 30A053)

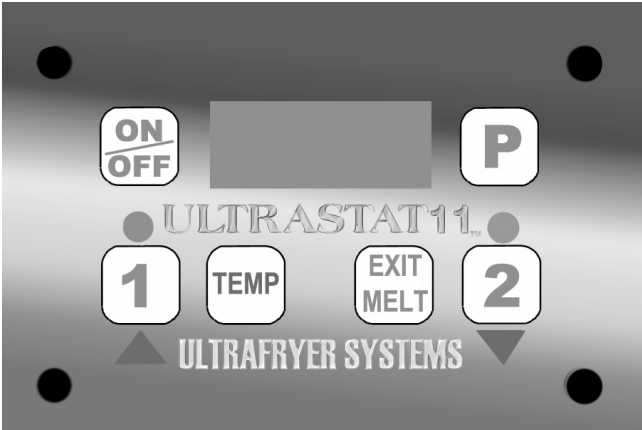



RATING PLATE

## RATING PLATE

Information on this plate includes the model and serial number; BTU/HR input rating of the burners; gas manifold pressure in inches W.C.; minimum inlet gas required, orifice size; and type of gas. This data is essential for proper identification when communicating with ULTRAFRYER SYSTEMS or requesting special parts or information. The rating plate is located on the left-most rear panel of the fryer.

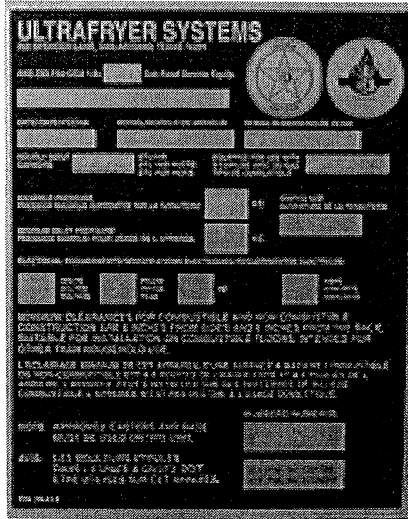

> [Important] : THE FRYER MUST ONLY BE CONNECTED TO THE TYPE OF GAS IDENTIFIED ON THIS RATING PLATE!

## PRE-INSTALLATION

### General

Safe and satisfactory operation of a gas fryer depends on its proper installation. Installation must conform to local codes or, in the absence of local codes, with the current National Fuel Gas Code ANSI Z223.1 (latest edition). In Canada, gas installation shall be in accordance with the current CAN/CGA B 149.1 and .2 installation codes and/or local codes. Each fryer bank should be installed as follows:

1. Placed beneath a properly designed exhaust hood.
2. Installed by a licensed Electrician and Plumber.
3. Connected to the type gas for which the unit was fabricated as shown on the rating plate.
4. Connected to the proper size pressure regulator installed in the gas supply line and adjusted to the proper manifold pressure.
5. Connected to the main gas supply line with the proper size line.
6. Restrained by use of a restraining device to avoid splashing of hot liquid and to assure tension cannot be placed on the gas or electrical lines or fittings.

**Caution:** DO NOT MOVE A FRYER FILLED WITH HOT LIQUID

**Caution:** THE FRYER MUST BE RESTRAINED BY USE OF A RESTRAINING DEVICE TO PREVENT TIPPING TO AVOID THE SPLASHING OF HOT OIL

### Clearances

The appliance must be kept free and clear of all combustibles. The minimum clearance from combustible and noncombustible construction is 6" (152 mm) from the sides, and 6" (152 mm) from rear. The fryer may be installed on combustible floors.

**WARNING** - Adequate clearances **must** be provided to ensure proper airflow and cooling for the blower motor. Failure to provide clearances *will void* the Ultrafryer limited warranty and could result in equipment/property damage.

### Standards

Installation **must** be planned in accordance with all applicable state and local codes, taking into account the following:

1. The fryer and its individual shutoff valve must be disconnected from the gas supply piping system during any pressure testing of that system at pressures in excess of  $\frac{1}{2}$  psig (3.45kPa). In Canada, gas installation shall be in accordance with the current CAN/CGA B 149.1 and .2 installation codes and/or local codes.
2. The fryer **must** be isolated from the gas supply piping system by closing its individual manual shutoff valve during any pressure testing of the gas supply piping system at pressures equal to or less than  $\frac{1}{2}$  psig (3.45kPa).
3. When installed the fryer must be electrically grounded in accordance with local codes, or in the absence of local codes, in accordance with the current National Electrical code ANSI/NFPA 70 (latest edition). In Canada electrical installation must be in accordance with the current CSA C22.1 Canadian Electrical Code and/or local codes.
4. Other applicable nationally recognized installation standards such as:

National Fuel Gas Code ANSI Z223.1 (latest edition)

American Gas Association

PRE-INSTALLATION

1515 Wilson Blvd.

Arlington, VA 22209

NFPA Standards #54, #94 and #221 (latest edition)

National Fire Protection Association

470 Atlantic Avenue

Boston, MA 02110

ANSI Z21.69/CAN/CGA-6.16 AND Z21.41/CAN1 6.9

5. Exhaust hood, when installed must conform to the current NFPA 54-1 and Canadian CAN/CGA-1.11 (latest edition)

> **[Important]** : Local building codes will usually **not** permit a fryer with its open tank of hot oil to be installed immediately next to an open flame of any type, whether a broiler or an open burner or range. Check local codes before beginning installation.

#### **Air Supply And Ventilation**

The area around the appliance must be kept clear of any combustible or flammable products and avoid any obstruction to the flow of ventilation air as well as for ease of maintenance and service. **NOTHING** is to be stored in the interior of the fryer's cabinet except the filter tub assembly.

**WARNING - Adequate clearances must be provided to ensure proper airflow and cooling for the blower motor. Failure to provide clearances will void the Ultrafryer limited warranty and could result in equipment/property damage.**

In addition to the above, the following *must* also be provided:

1. A means must be provided for any commercial, heavy duty-cooking appliance to exhaust combustion wastes outside of the building. It is essential that a fryer be set under a powered exhaust hood or that an exhaust fan be provided in the wall above the unit, as exhaust temperatures are in the vicinity of 400°F (204°C).

**Note:** Strong exhaust fans in a hood or in the overall air conditioning system can produce slight air drafts in the room, which can interfere with burner performance and be hard to diagnose. Air movement should be checked during installation and if burner problems persist, makeup air openings or baffles may have to be provided in the room.

2. Exhaust temperature, in addition to the open tank of hot oil, make the storage of anything on shelving over or behind the fryer unsafe.
3. Filters and drip troughs should be part of any industrial hood, but consult local codes before constructing and installing any hood.
4. Provisions must be made for an adequate supply of fresh air and adequate clearance must be maintained for air openings into the combustion chamber.

## RECEIVING AND INSTALLING

### Unpacking

Check that the container is upright. Use an outward prying motion. **DO NOT USE A HAMMER** - to remove the carton. Check the fryer for visible damage; if damage has occurred do not refuse shipment, but contact the carrier and file the appropriate freight claims.

### Installing

If sufficient space is available, roll the assembled fryer into the building, to its operating location and proceed to the LEVELING Section. In the event the entrance doors are too narrow to roll the assembled fryer into the building; disassemble then reassemble the fryer as follows:

**Danger:** IMPROPER INSTALLATION, ADJUSTMENT, ALTERATION, SERVICE OR MAINTENANCE CAN CAUSE PROPERTY DAMAGE, INJURY OR DEATH. READ THE INSTALLATION, OPERATING AND MAINTENANCE INSTRUCTIONS THOROUGHLY BEFORE INSTALLING OR SERVICING THIS EQUIPMENT.

**Note:** As there are various configuration options, the following procedures are intended as a general guide to aid in the disassembly and reassembly of the Fryer for installation.

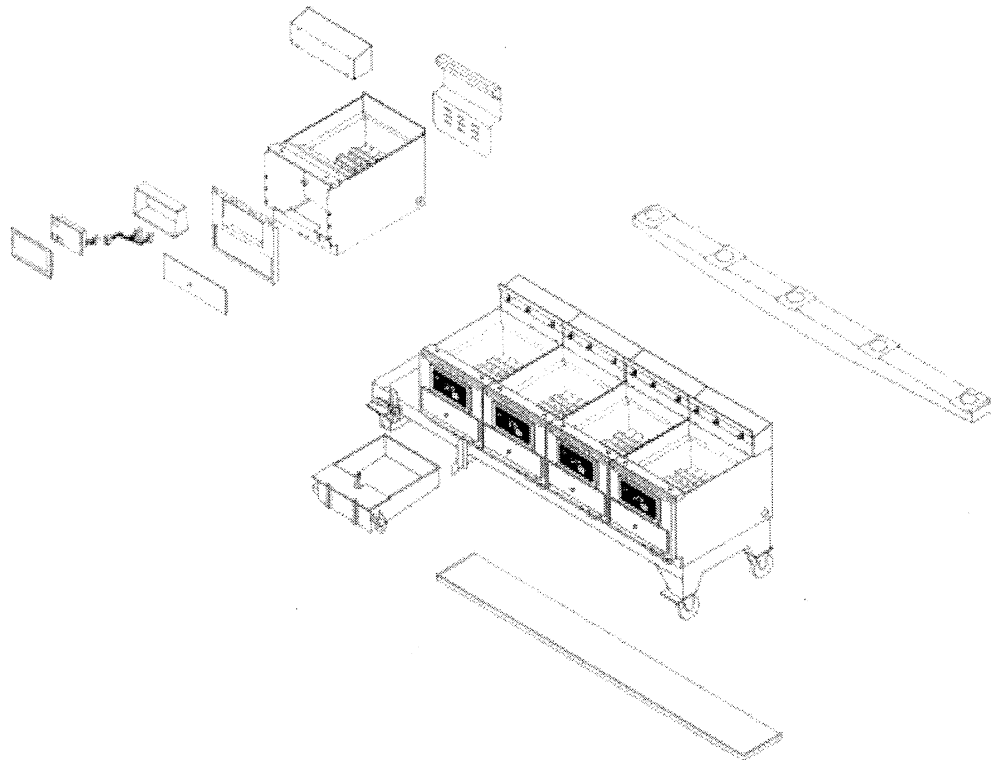

### Disassembly

#### Facing the FRONT of the fryer

1. Number each vat cabinet from LEFT to RIGHT and place these numbers on the front and rear panel of each cabinet.
2. Remove the door assembly for each cabinet as follows:
  - a. Remove the Service access door and place it in the vat.

## RECEIVING AND INSTALLING

- b. Locate and loosen the six (6) (three on each side) 1/4" speed nuts from inside of the door frame.
  - c. Gently lift up on the door assembly until it can be removed from the frame.
  - d. Locate and remove the cannon plug from the backside of the Controller door assembly. The door assembly can now safely be placed in the fryer vat for reinstallation.
3. CAREFULLY remove the APRON from the fryer bank as follows:
    - a. Locate and remove the two (2) 1/4-20 wing nuts, 1/4" (6 mm) split washers, and 3/8" (18 mm) flat washers from each 1/4-20 weld stud beneath each cabinet hat section.  
**Note:** It may be necessary to cut the SILICONE SEAL between the apron and vat cabinets to separate the apron. DO NOT DAMAGE THE GASKET.
  4. Remove the JOINER STRIP located between each set of vats; then cut the SILICONE SEAL between the vats.
  5. CAREFULLY separate the SHORTENING DRAIN TROUGH from each 2" (51 mm) ball valve plate by removing the four (4) 1/4-20 hex head bolts and nuts; then remove the drain trough from the fryer.
  6. Remove the 10-24 truss head screw and nut on the right hand side of each vat used to secure adjoining vats and remove the 10-24 truss head screw and nut that secures the "extreme" left hand vat cabinet to the base frame.

### Facing the REAR of the fryer

1. Remove the REAR panel from each vat by removing the four (4) pan head self-tapping screws.
2. Remove the two (2) 10-24 truss head screws and nuts on the right hand side of each vat used to secure adjoining vats.
3. CAREFULLY remove the two (2) Phillips head, self-tapping screws along the BOTTOM flange of each cabinet.
4. CAREFULLY loosen and separate the flexible gas line from the gas manifold flare fitting on each vat.
5. CAREFULLY disconnect the SHORTENING LINE RED and WHITE heater tape electrical wires terminated in a 3 PIN WHITE connector from its mating receptacle located on the left hand side of the "extreme" LEFT HAND vat.  
**Note:** BLACK and WHITE CABLETYES may have to be removed to separate connectors.
6. CAREFULLY disconnect the FILTER PUMP MOTOR RED, GREEN and WHITE electrical wires terminated in a 4 PIN WHITE connector from its mating receptacle located on the left hand side of the "extreme" LEFT HAND vat.
7. CAREFULLY disconnect the POWER LINE BLACK and WHITE electrical wires terminated in a 4 PIN WHITE connector from its mating receptacle located on the left hand side of the "extreme" LEFT HAND vat.
8. SECURE the SHORTENING LINE to the base frame on the LEFT HAND end of the fryer bank; then CAREFULLY loosen and separate the shortening line union attached to each 3/4" (19 mm) ball valve.
9. CAREFULLY remove each cabinet from the base frame, carry each cabinet into the building; then place the base frame into position in the kitchen.
10. PRIOR to reassembling the fryer bank:
  - a. Remove DRIED silicone used to seal the apron to vats, opening between each set of vats, front and rear of each cabinet, lower edge of the two (2) end vats, and perimeter of the base frame.
  - b. THOROUGHLY clean the Teflon tape from all GAS and SHORTENING fittings and pipes; then wrap all male pipes and fittings with new Teflon tape.

### Reassembly

1. Place each vat cabinet in numerical order in FRONT of the base frame from LEFT to RIGHT.
2. Install each vat cabinet on the base frame as follows:
  - a. Place a bead of silicone around the perimeter of the base frame for the FIRST

## RECEIVING AND INSTALLING

- vat cabinet.
- b. CAREFULLY place VAT CABINET #1 in position on the base frame; then secure the cabinet to the base frame by installing a 10-24 truss head screw and nut on the left hand flange to the base frame then install two (2) Phillips head self-tapping screws in the two holes on the REAR bottom flange of the cabinet.
  - c. Repeat the above procedures to install remaining vat cabinets on the base frame.
3. When all vat cabinets are installed on the base frame, secure the cabinets as follows:
- a. Place a bead of silicone along the FRONT, TOP and REAR space between vat cabinets #1 and #2.
  - b. Install a 10-24 truss head screw and nut in the ¼" (6 mm) holes on the FRONT right hand side of vat cabinet #1 and left hand side of vat cabinet #2.
  - c. Install two (2) 10-24 truss head screws and nuts in the two (2) 13/64" (5 mm) holes on the REAR left hand side of vat cabinet #1 used to secure it to cabinet #2.
  - d. Repeat the above procedures to secure remaining vat cabinets to adjoining vat cabinets.
4. Perform these steps facing the REAR of the fryer:
- a. CAREFULLY connect each shortening line union HAND TIGHT, remove the device used to secure the SHORTENING LINE to the LEFT end of the base frame; then SECURELY tighten each shortening line union.
  - b. SECURELY connect each manual gas valve flexible gas line to the male flare fitting on the manifold.
  - c. SECURELY connect the SHORTENING LINE RED and WHITE heater tape electrical wires terminated in a 3 PIN WHITE connector to its mating receptacle on the left-hand side of the "extreme" LEFT HAND vat. Install a small cabletye on the connection to assure these connectors cannot be separated.
  - d. SECURELY connect the FILTER PUMP MOTOR RED, GREEN and WHITE electrical wires terminated in a 4 PIN WHITE connector to its mating receptacle located on the left-hand side of the "extreme" LEFT HAND vat.
  - e. SECURELY connect the POWER LINE BLACK and WHITE electrical wires terminated in a 4 PIN WHITE connector to its mating receptacle located on the left hand side of the "extreme" LEFT HAND vat.
  - f. Replace the REAR PANEL on each vat cabinet using eight (8) pan head self-tapping screws in each cabinet panel and fan cover.
5. Perform these steps facing the FRONT of the fryer:
- a. CAREFULLY position the drain trough beneath the fryer; then SECURE the drain trough to each 2" (5mm) ball valve plate using four (4) ¼-20 hex head bolts and nuts previously removed.
  - b. Remove any dried silicone from each JOINER STRIP, place a bead of silicone in each strip; then place the joiner strip over the edge of all adjoining fryer vats.
  - c. CAREFULLY replace the APRON as follows:

It is advisable to use a clamping method (vice grips, etc) at each vat location when installing the apron retaining hardware.

**Note:** care should be taken to avoid damaging the upper apron surface when using clamps.

1. Place a bead of silicone (supplied) along the FRONT edge of each vat cabinet and fill the REAR corners of the apron with silicone so it will be flush with the top of the apron.
2. CAREFULLY position the APRON on the fryer bank ensuring the BOTTOM of the RED apron gasket is resting on the front top edge of each vat cabinet as illustrated below.



RECEIVING AND INSTALLING

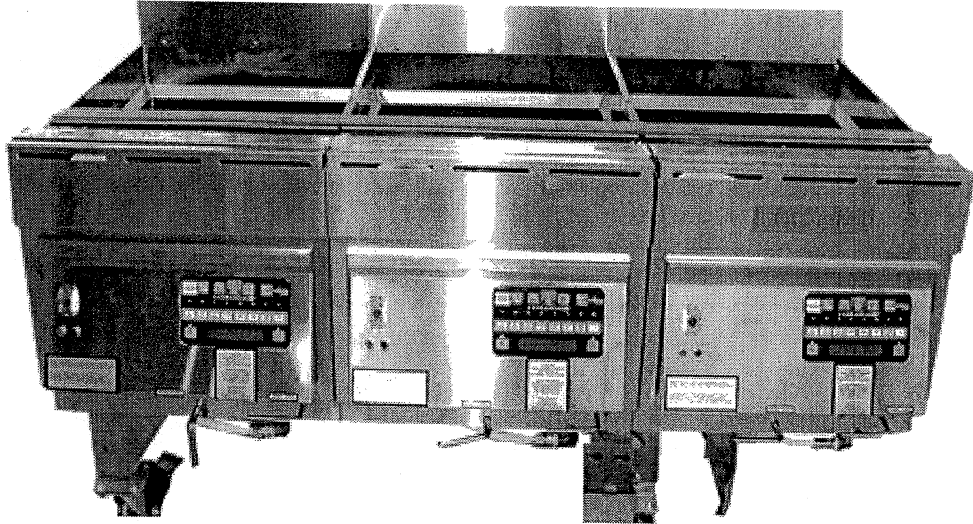

3. LOOSELY install one (1) ¼" flat washer, ¼" lock washer and ¼" wing nut on ALL apron retaining studs at each vat location prior to tightening.

> **[Important]** : UFS does not recommend or warranty the use of substituted hardware (i.e., lock nut, nyloc) in lieu of the supplied wing nuts.

4. Once ALL wing nuts are installed, INCREMENTALLY tighten each wing nut until SNUG (finger tight) beginning with the center vat and working outward.

**Caution:** DO NOT USE WING NUTS TO TIGHTEN THE APRON AGAINST THE SEAL, DOING SO CAN CAUSE WELD STUD FAILURE AND POSSIBLE DAMAGE TO APRON SURFACE.

5. Place a bead of silicone along the interior seam of the apron and front panel of each vat, as well as, each vat corner and apron seam as illustrated below.

**Caution:** FAILURE TO SEAL THESE AREAS WILL PERMIT HOT SHORTENING TO SPLASH INTO THE SPACE ALLOWING OIL TO SEEP INTO THE BURNER AREA.

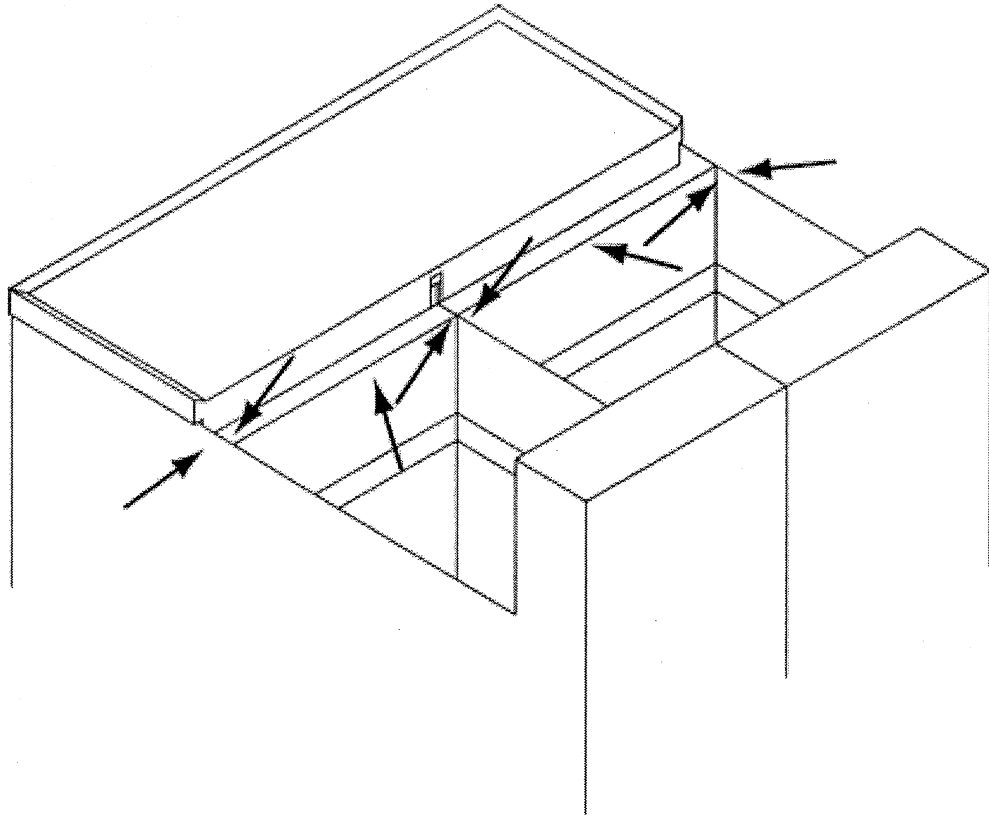

### Leveling

To ensure that the fryer is properly level:

1. Roll the fryer to its operating location and check to be sure it is level at this location. If not, loosen the casters and insert the appropriate number of shim plates between leg and caster plates then retighten the caster bolts.
2. If the floor is smooth and level, adjust to the high corner and measure with a spirit level. If the floor is uneven or has a decided slope, level the unit with metal shims.

**Note:** A caster may not return exactly to the same position after being moved, which may require re-leveling after each move.

### Gas Connection

The gas supply (service) line must be the same size or greater than the inlet line of the appliance. **THE GAS SUPPLY LINES MUST BE SIZED TO ACCOMMODATE ALL THE GAS FIRED EQUIPMENT THAT MAY BE CONNECTED TO THAT SUPPLY.** Refer to the Inlet Gas Line Sizing and Inlet Gas Requirements Tables in the GENERAL INFORMATION section.

**Note:** Sealant used on all pipe joints must be resistive to butane and propane gas.

### Requirements

1. Manual Shut Off Valve:

This supplier-installed valve must be installed in the gas service line ahead of the appliance and in a position where it can be reached quickly in the event of an emergency.

2. Pressure Regulator:

## RECEIVING AND INSTALLING

All commercial cooking equipment must have a pressure regulator on the incoming service line for safe and efficient operation, because service pressure may fluctuate with local demand. External regulators are not required on this fryer, as that function is performed by a combination gas control valve, however if the incoming pressure is in excess of ½ psig, a step-down regulator will be required.

### 3. Natural Gas:

Require 7" (178 mm) water column (W.C.) inlet pressure to the fryer's combination gas control valve for proper operation, when all gas units are operating simultaneously.

### 4. Butane And Propane Gas Fryers:

Require 14" (356 mm) (W.C.) inlet pressure to the fryer's combination gas control valve for proper operation, when all gas units are operating simultaneously.

This inlet pressure **MUST** be checked with a Manometer **PRIOR** to placing the fryer in operation.

**Danger: IF THE INLET GAS PRESSURE AT THE FRYER'S COMBINATION GAS CONTROL VALVE EXCEEDS ½ lb/in<sup>2</sup> (.035 kg/cm<sup>2</sup>) OR APPROXIMATELY 14" (356 mm) W.C., AN EXTERNAL REGULATOR MAY BE NEEDED TO PREVENT DAMAGE TO THE COMBINATION GAS VALVE AND VOIDING OF THE WARRANTY. FAILURE TO ADDRESS THIS COULD RESULT IN EXPLOSION OR FIRE.**

### 5. Combination Gas Control Valve:

The correct combination gas control valve and orifice is installed at the factory for BUTANE, NATURAL and PROPANE units based on each Purchase Order. This valve should be CHECKED/ADJUSTED by qualified service personnel using proper test equipment for the following OUTLET gas pressure **PRIOR** to start-up of a fryer.

- a. **Natural Gas fryers** 4" (102mm) water column (W.C.)
- b. **Butane/Propane fryers** 10" (254mm) water column (W.C.)

### 6. Rigid connections:

Visually check and purge any installer-supplied intake pipe(s) with compressed air to clear dirt particles, threading chips or any other foreign matter before connecting to the service line as these particles may clog the orifice when gas pressure is applied. All connections must be tested with a soapy solution before lighting the fryer. Putting an open flame beside a new connection is not only dangerous, but will often miss small leaks that a soapy solution would find.

**DO NOT USE AN OPEN FLAME TO CHECK FOR LEAKS!**

### 7. Flexible Couplings, Connectors:

The installation is to be made with a connector that:

- a. Complies with the Standard for Connectors for Movable Gas Appliances, ANSI Z21.69, CAN/CGA-6.16, and a quick-disconnect device that complies with the Standard for Quick-Disconnect Devices for Use With Gas Fuel, ANSI Z21.41, CAN1-6.9.
- b. Adequate means must be provided to limit the movement of the appliance without depending on the connector and the quick disconnect device or its associated piping to limit the appliance movement.
- c. The location(s) where the restraining means may be attached to the appliance shall be specified.

**DOMESTIC CONNECTORS ARE NOT SUITABLE!**

**Connecting the fryer**

Connect the gas manifold to the building gas supply line by means of an APPROVED flexible gas line as shown in the figure below.

**Caution:** THE BUILDING GAS SUPPLY LINE MUST BE SIZED TO PROVIDE THE VOLUME OF GAS REQUIRED FOR PROPER OPERATION.

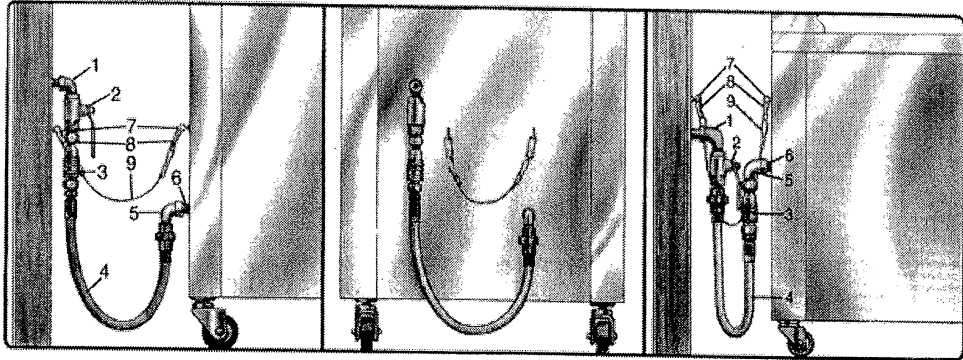

**Danger:** THE RESTRAINT DEVICE (ITEM 9) MUST BE INSTALLED TO ASSURE TENSION CANNOT BE PLACED ON THE GAS OR ELECTRICAL LINES AND FITTINGS.

Table1. Gas Connection

ITEM #	DESCRIPTION
1	BUILDING GAS SERVICE LINE
2	MAIN GAS SHUT-OFF VALVE
3	QUICK-DISCONNECT
4	FLEX CONNECTOR
5	ELBOW
6	APPLIANCE MANIFOLD/NIPPLE
7	EYELET FASTENERS
8	SPRING HOOK
9	RESTRAINING CHAIN

**Fryer Service**

The fryer is equipped with swivel casters. To service the fryer:

1. Turn OFF gas supply at the supply source.
2. Disconnect the flexible gas line quick-disconnect.
3. Disconnect restraint means and roll fryer out for rear service access.
4. When the fryer is repositioned, be sure to reconnect the restraint and level the fryer.

**Electrical Connection**

The MAXIMUM current draw per vat at Initial Startup or during a Warm-up Cycle will be 3 Amperes at 120 Volts. When running the Filter System simultaneously allow for an additional 3 Amperes. Refer to the wiring diagram attached to the fryer for internal

RECEIVING AND INSTALLING

electrical connections.

**Caution:** This appliance is equipped with a three-prong (grounding) plug for your protection against shock hazard and should be plugged directly into a properly grounded three-prong receptacle. Do not cut or remove the grounding prong from this plug.

**BP30-18 - 110,000**

Gas Type	Gas Vlv Press (W.C.)	Orifice Size	Rating	Inlet Gas Flow at STP
Natural	4.0	10	110,000 BTU/Hr 116 MJ/Hr	110 FT <sup>3</sup> /Hr 3.1 M <sup>3</sup> /Hr
Propane	10.0	32	110,000 BTU/Hr 116 MJ/Hr	44 FT <sup>3</sup> /Hr 1.25 M <sup>3</sup> /Hr
Butane	10.0	33	110,000 BTU/Hr 116 MJ/Hr	34 FT <sup>3</sup> /Hr .97 M <sup>3</sup> /Hr

**BP30-18 - 80,000**

Gas Type	Gas Vlv Press (W.C.)	Orifice Size	Rating	Inlet Gas Flow at STP
Natural	4.0	20	80,000 BTU/Hr 84 MJ/Hr	80 FT <sup>3</sup> /Hr 2.3 M <sup>3</sup> /Hr
Propane	10.0	34	80,000 BTU/Hr 84 MJ/Hr	36 FT <sup>3</sup> /Hr 0.9 M <sup>3</sup> /Hr
Butane	10.0	37	80,000 BTU/Hr 84 MJ/Hr	25 FT <sup>3</sup> /Hr 0.71 M <sup>3</sup> /Hr



**BP30-20 - 120,000**

Gas Type	Gas Vlv Press (W.C.)	Orifice Size	Rating	Inlet Gas Flow at STP
Natural	4.0	7	120,000 BTU/Hr 127 MJ/Hr	120 FT <sup>3</sup> /Hr 3.4 M <sup>3</sup> /Hr
Propane	10.0	3.3mm	120,000 BTU/Hr 127 MJ/Hr	48 FT <sup>3</sup> /Hr 1.45 M <sup>3</sup> /Hr
Butane	10.0	31	120,000 BTU/Hr 127 MJ/Hr	37.5 FT <sup>3</sup> /Hr 1.06 M <sup>3</sup> /Hr

**BP30-20 - 80,000**

Gas Type	Gas Vlv Press (W.C.)	Orifice Size	Rating	Inlet Gas Flow at STP
Natural	4.0	19	80,000 BTU/Hr 84 MJ/Hr	80 FT <sup>3</sup> /Hr 2.3 M <sup>3</sup> /Hr
Propane	10.0	35	80,000 BTU/Hr 84 MJ/Hr	32 FT <sup>3</sup> /Hr 0.9 M <sup>3</sup> /Hr
Butane	10.0	37	80,000 BTU/Hr 84 MJ/Hr	25 FT <sup>3</sup> /Hr .71 M <sup>3</sup> /Hr

**BP30-14**

Gas Type	Gas Vlv Press (W.C.)	Orifice Size	Rating	Inlet Gas Flow at STP
Natural	4.0	16	90,000 BTU/Hr 95 MJ/Hr	90 FT <sup>3</sup> /Hr 2.5M <sup>3</sup> /Hr
Propane	10.0	32	90,000 BTU/Hr 95 MJ/Hr	36 FT <sup>3</sup> /Hr 1.0M <sup>3</sup> /Hr
Butane	10.0	36	90,000 BTU/Hr 95 MJ/Hr	28 FT <sup>3</sup> /Hr .8M <sup>3</sup> /Hr

## INITIAL STARTUP

### General

New units are wiped clean at the factory to remove any visible signs of dirt, oil, grease, etcetera, remaining from the manufacturing process. Each fryer vessel should be thoroughly washed with hot soapy water to remove film residues, installation dust or debris; and then wiped dry before being used for food preparation.

### Startup

The fryers are tested, adjusted and calibrated prior to being shipped: however adjustments may be necessary on installation to meet local conditions, high or low gas pressure, differences in altitudes, variations in gas characteristics and to correct possible problems caused by rough handling or vibration during shipment. Initial calibration or adjustment is the responsibility of the customer and will not be covered by the Ultrafryer Systems warranty.

> **[Important]** : Calibration and adjustments must be performed by qualified personnel.

### Lighting Instructions

Each fryer is equipped with a spark ignition system, to test this system perform the following steps, in sequence:

1. Turn the On/Off switch to the OFF position.
2. Fill the fryer vessel with hot or cold water to the SHORTENING LEVEL mark.

**Caution:** IF THE MAIN BURNERS ARE OPERATED WITH THE VESSEL EMPTY, THE HEAT WILL CAUSE THE JOINTS OF THE FRYER VESSEL TO BE PLACED UNDER UNDO STRESS AND MAY CAUSE THE HEAT EXCHANGER VESSEL TO WARP OR BUCKLE, VOIDING WARRANTY.

3. Turn the manual gas valve behind the fryer control access door of the fryer to the OFF position and wait FIVE (5) minutes for any accumulated gas to disperse.
4. ENSURE the MAIN gas shutoff is in the ON position, MANUAL VALVE on the combination GAS CONTROL VALVE (located behind the fryer control access door) is in the ON position and the Vent Hood EXHAUST FAN is ON.
5. Turn the manual gas valve to the ON position.
6. Position the switch to the ON position; then place the DTMR or ULTRASTAT Cooking Computer into the MELT MODE.

**Danger:** DO NOT USE A MATCH OR CANDLE TO LIGHT A FRYER. EVER!

### Sequence Of Ignition

When the lighting instruction steps are performed in the sequence listed above, the following will occur:

- Blower will come ON activating the air pressure switch.
- The air pressure switch (PAR-3) will CLOSE completing the electrical circuit to the transformer.
- The transformer will supply 24 volts to the IGNITOR MODULE and GAS CONTROL VALVE, and the ignitor will SPARK lighting the gas in the burner.

**Danger:** WHEN CHECKING FOR BURNER PERFORMANCE, DO NOT STAND WITH YOUR FACE CLOSE TO THE BURNER. IT MAY LIGHT WITH A "POP" AND COULD FLASH BACK AND CAUSE FACIAL BURNS.

**Note:**

#### INITIAL STARTUP

1. If the burner flame fails, it will be sensed by the SPARK IGNITOR, the Spark Ignitor Module will open the electrical circuit to the GAS CONTROL VALVE shutting off gas to the burner.
2. If the blower fails, the air pressure switch will open the electrical circuit to the TRANSFORMER removing electrical power from the SPARK IGNITOR MODULE and GAS CONTROL VALVE shutting off gas to the burner.

#### **Burner Operation test**

Perform the above LIGHTING INSTRUCTIONS and observe operation of the burners. When satisfied that the burner is operating properly, drain the fryer vessel of water and dry the vessel thoroughly; then fill the fryer vessel with shortening.

#### **Shutdown Procedures**

Turn "ON-OFF" power switch to "OFF" position and close manual gas valve.

#### **Shortening Installation**

Install shortening as per the instructions in the SHORTENING DISPOSAL, BOIL-OUT & INSTALLATION Section of this manual.

MODEL 2005 FRYER

This fryer is equipped with both a Default-to-Manual-Restart (DTMR) control and an Ultrastat U25 Cooking computer. Operating controls, which are located on the Controller Access door, include: the On/Off Switch, AMBER *Power* Indicator Lamp and the RED *Heating* Indicator Lamp. The Electronic Thermostat and other fryer components are located below the Controller Access panel and are accessed via a service access door. The main drain valve and shortening return pump handles are located beneath the service access door.

Figure1. Fryer Operating Controls

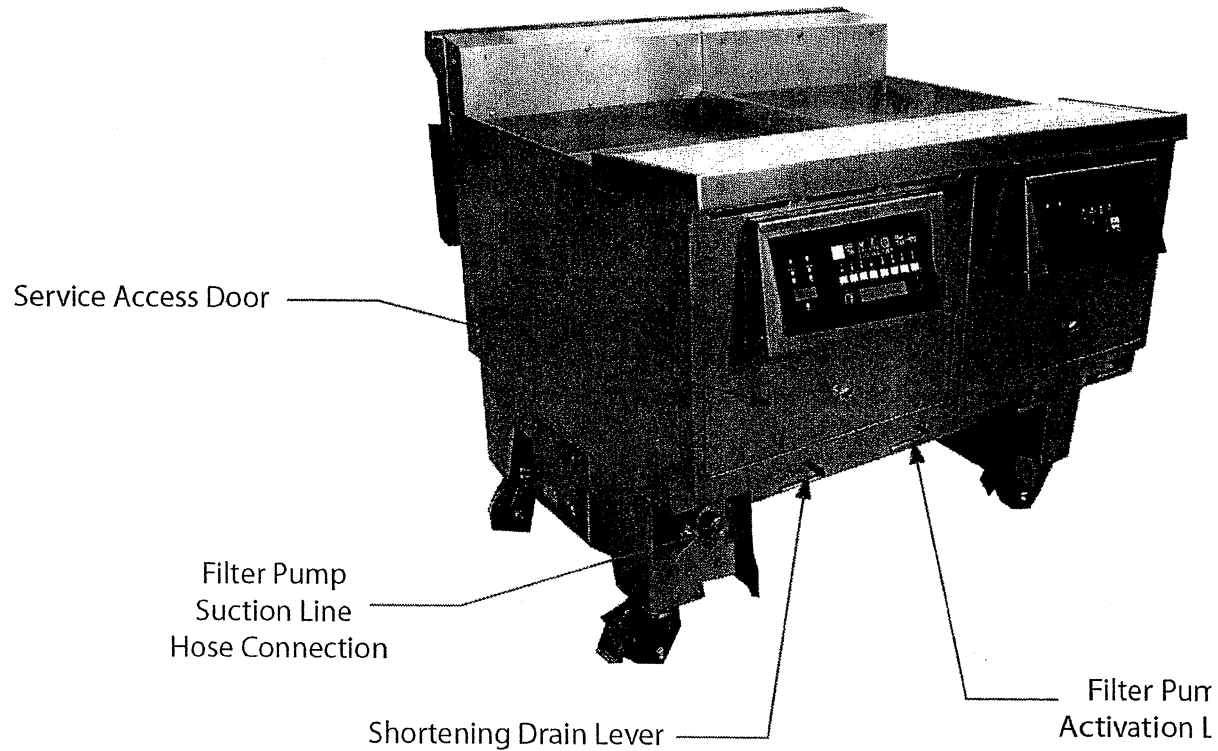

Figure1. DTMR Controller Door Operating Controls

MODEL 2005 FRYER

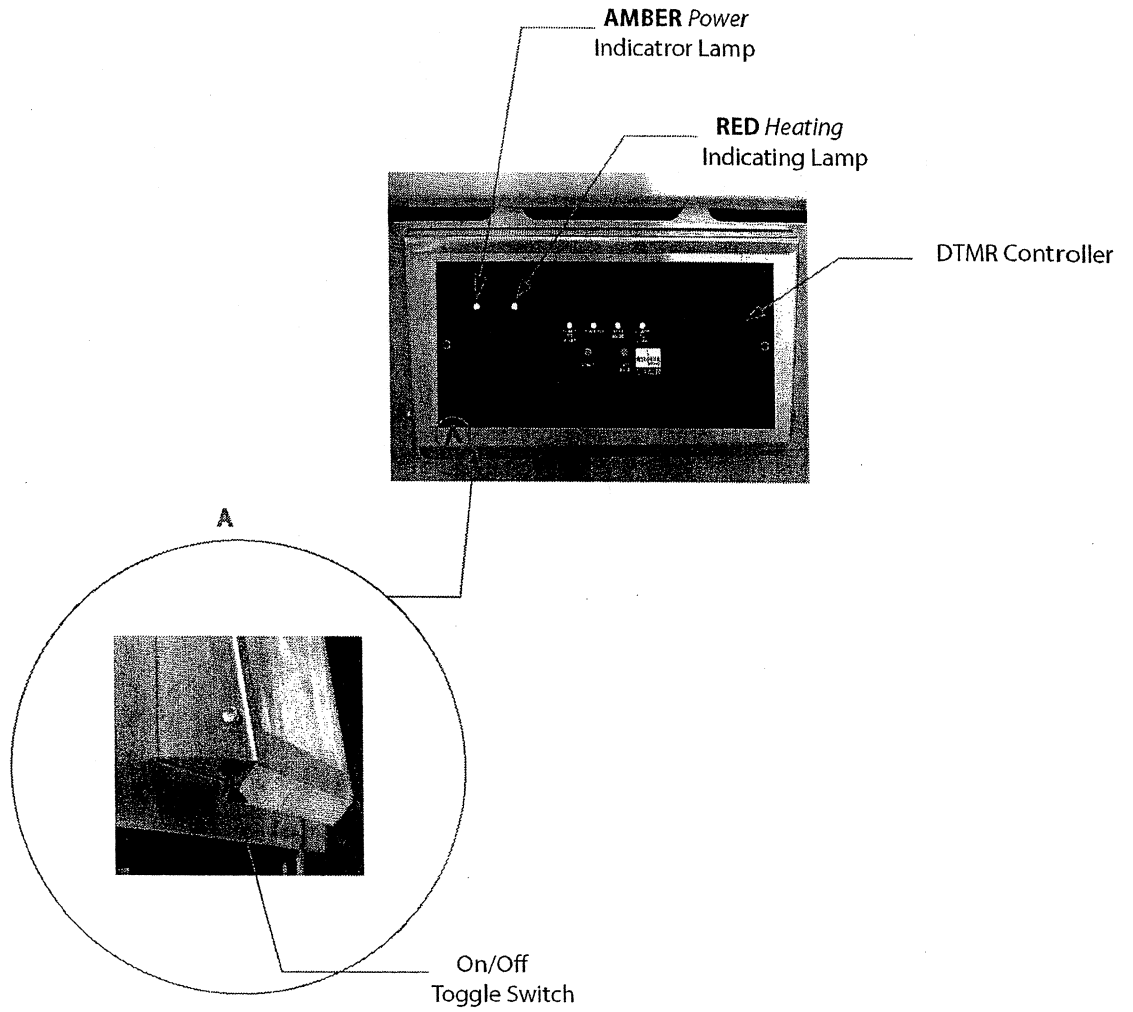

Figure1. U25 Computer With Self Cleaning Operating Controls



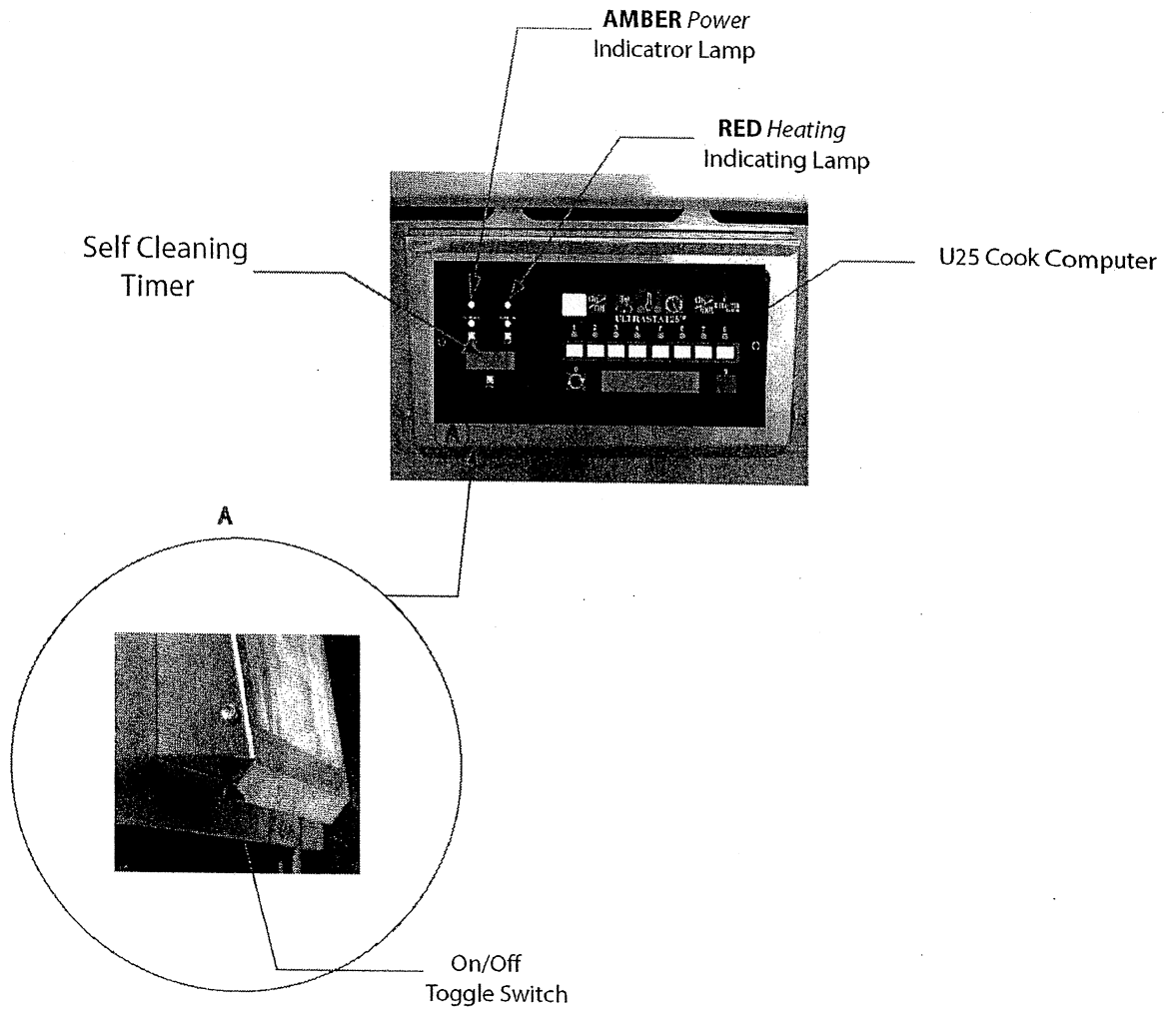

Figure1. PAR-3 Gas Fryer Components Location

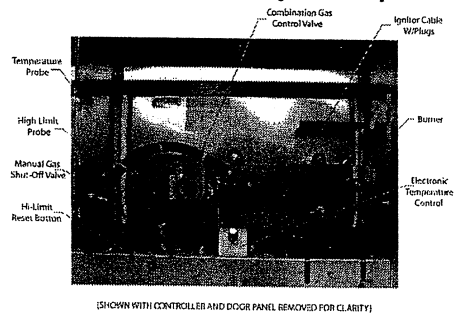
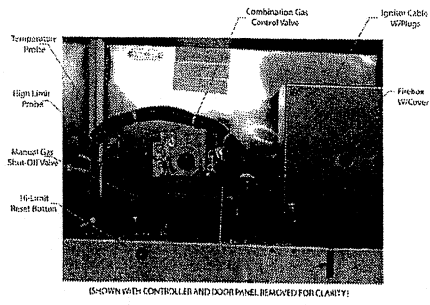

Figure1. PAR-2 Gas Fryer Components Location

# MODEL 2005 FRYER



(SHOWN WITH CONTROLLER AND DOOR PANEL REMOVED FOR CLARITY)

## DTMR GENERAL INFORMATION

The Default-To-Manual-Restart, herein referred to as DTMR, Controller is intended to reduce the possibility of "operator errors" that can result in DRY FIRING a fryer causing shortening to be scorched, damage to the heat mechanism, and/or a vat fire.

### Safety

The DTMR Controller operates on 120 volt single phase electrical power, and like other electrical equipment, should not be operated with wet hands or while standing in water. Water should NEVER be sprayed on or at the Controller, as there is a danger of electrical shock and/or serious damage to its electrical circuitry. The Controller is located in close proximity to hot liquid shortening and care must be taken to avoid serious burns. The floor in front of, and area around the fryer should be kept as clean and dry as possible and when product is placed into a vat, care should be taken to not splash the hot shortening.

**Note:** Products should always be "placed" into the shortening, not thrown.

In the event, however, that the Controller is accidentally sprayed with water:

1. IMMEDIATELY turn the Fryer Power switch OFF and,
2. Contact a qualified service agent to check the Controller prior to resuming cooking operations. o do so, could result in damage to the Controller and/or personal injury.

### Approved Cleaning Procedures

Prior to cleaning, electrical power to the Controller should be turned OFF by placing the fryer power switch to the OFF position. A SLIGHTLY dampened cloth may then be used to clean the faceplate of the Controller. DO NOT USE any cleaner or degreaser as they may damage the overlay and/or internal circuitry of the controller. Any questions regarding correct cleaning procedures should be directed to the Customer Service Department at 1-800-525-8130.

## DTMR CONTROLLER FEATURES

### General

The Default-to-Manual-Restart (DTMR) Controller is connected to the fryer's electrical system to control operation of the fryer. Shortening temperature is controlled by an Electronic Thermostat. The DTMR contains a Default-to-Off circuit that will *DISABLE* the fryer anytime the Drain Valve is OPEN, and a Default-to-Melt circuit that will place the fryer in a SHORTENING MELT MODE to gradually and safely heat shortening.

**Note:** The DTMR is *AUTOMATICALLY* placed in the SHORTENING MELT MODE each time the fryer's power switch is turned ON.

### Pakstat Temperature Controller

Each Pakstat Temperature Controller is located inside the fryer cabinet and contains an adjustment knob that has a temperature range from 200°F (93°C) to 400°F (204°C) and will accurately maintain the shortening temperature within  $\pm 4^\circ$ . The temperature is factory preset and tested according to the specifications requested at the time of the order. Care should be taken when operating around the Controller Adjustment Knob to avoid inadvertent adjustment. Should adjustment be necessary, a **QUALIFIED** and **AUTHORIZED** Repairman should accomplish the procedures listed in the Electronic Thermostat Calibration section this manual.

### Control Panel Component Identification

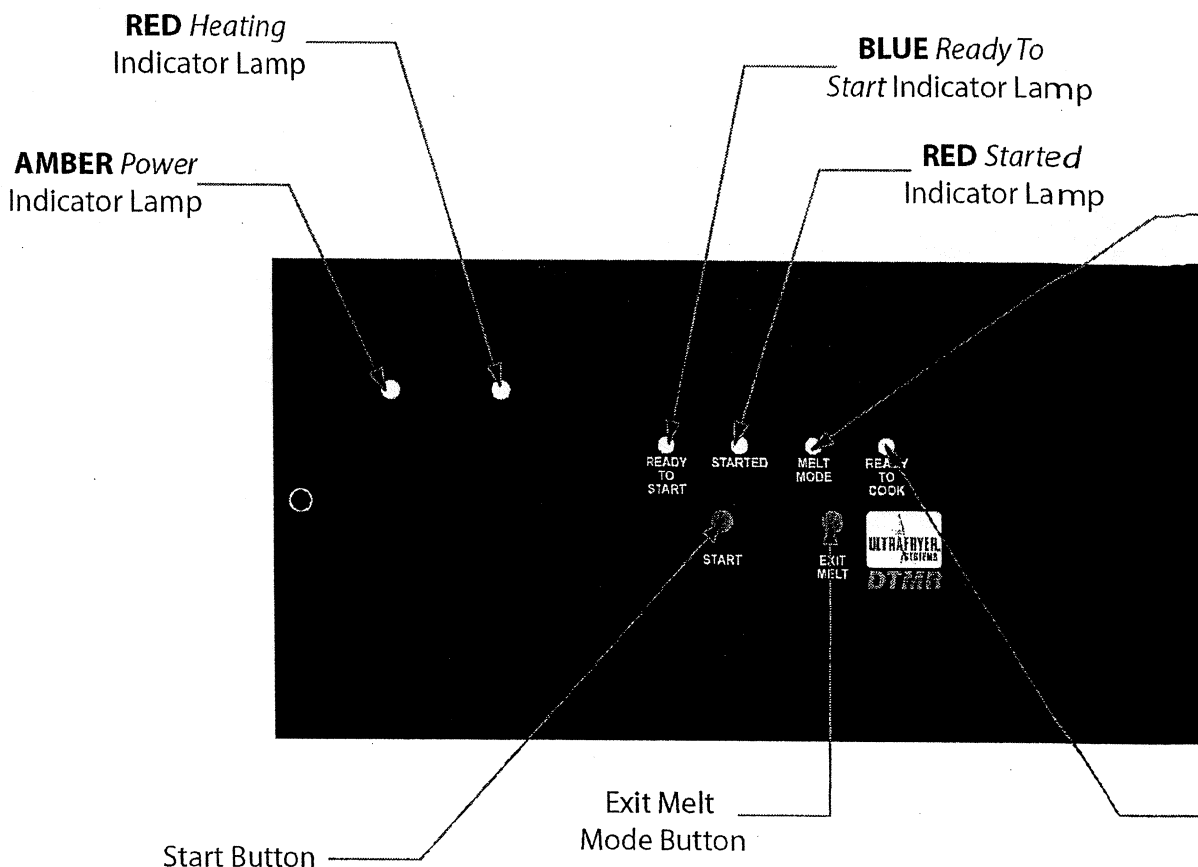

- **START BUTTON**

When this button is momentarily depressed, it places the fryer in operation.

- **BLUE READY TO START INDICATOR LAMP**

When illuminated indicates the fryer's On/Off switch is in the ON position, the Drain Valve is CLOSED and the fryer is properly configured for operation.

- **RED STARTED INDICATOR LAMP**

When illuminated indicates the START BUTTON has been depressed, placing the fryer in operation.

- **AMBER MELT MODE INDICATOR LAMP**

When illuminated indicates the fryer is in the MELT MODE and the timer in the Controller's Default-to-Melt circuit is cycling the fryer's heat mechanism ON and OFF to gradually and safely heat the shortening.

- **GREEN READY TO COOK INDICATOR LAMP**

When illuminated indicates the shortening is heated and the fryer is ready to initiate a cook cycle.

- **EXIT MELT BUTTON**

When this button is momentarily depressed, the Default-to-Melt electrical timer will switch the Controller to the FULL-ON position allowing the Electronic Thermostat to heat the shortening to its PRESET temperature.

- **AMBER POWER INDICATOR LAMP**

When illuminated indicates that electrical power is available to the fryer.

- **RED HEATING INDICATOR LAMP**

When illuminated indicates that the fryer heat mechanism is in operation.

## DTMR OPERATION

### Gas Fryer Operational Test

To operationally test an Ultrafryer Gas Fryer equipped with a Default-To-Manual-Restart (DTMR) control:

1. Turn the On/Off Power Switch to the OFF Position.
2. Fill the fryer vat with hot or cold water to the middle of the "E" in the word LEVEL of the applicable shortening level mark on the rear of the vat.
3. Turn the MANUAL gas valve to the OFF position and wait FIVE (5) minutes for any accumulated gas to disperse.
4. ENSURE the MAIN gas shutoff valve is in the ON position, and that the EXHAUST FAN is ON.
5. Turn the MANUAL gas valve to the ON position.
6. Perform the following steps, in the order listed:

**Table1. Gas DTMR Test Start-Up Procedures**

ITEM	ACTION	RESPONSE
1	ENSURE the drain valve is in the CLOSED position and that water is at the proper level; then turn the switch to the ON position.	A. The AMBER power indicator will LIGHT. B. BLUE READY TO START lamp will LIGHT.
<b>CAUTION: CAUTION: PRIOR TO PROCEEDING TO STEP 2 VISUALLY CHECK THAT THE HEAT MECHANISM IS COVERED WITH AT LEAST 2" (51 mm) OF WATER.</b>		
2	Depress, then release the momentary START button	A. RED STARTED lamp and AMBER MELT MODE lamp will light. B. BLUE READY TO START lamp will turn OFF. C. A TIMER in the Default-To-Melt electrical circuit will begin cycling the fryer heat mechanism ON for twelve (12) seconds and OFF for 28 seconds to safely heat the water.
<b>CAUTION: CAUTION: PRIOR TO PROCEEDING TO STEP 3, VISUALLY CHECK THAT THE WATER COMPLETELY COVERS THE HEAT MECHANISM.</b>		
3	When the water is heated depress, then release the momentary EXIT MELT button.	A. AMBER MELT MODE lamp will turn OFF and the RED STARTED lamp will remain lit. B. The TIMER in the Default-To-Melt circuit will switch to the FULL ON position, allowing the Electronic Thermostat to heat the water.
4	When the water begins to boil, turn the On/Off switch to the OFF position	The AMBER power lamp will turn OFF.

5	After the water in the vat and metal surfaces of the fryer have COOLED, drain the water into a floor drain.
---	---

**Fryer Operation**

To safely operate an Ultrafryer Gas Fryer equipped with the DTMR as follows:

**Table1.**

ITEM	ACTION	RESPONSE
1	ENSURE the drain valve is in the CLOSED position and that the shortening is at the proper level; then turn the switch to the ON position.	A. The AMBER power indicator will LIGHT. B. BLUE READY TO START lamp will LIGHT.
<b>CAUTION: CAUTION: PRIOR TO PROCEEDING TO STEP 2 VISUALLY CHECK THAT THE HEAT MECHANISM IS COVERED WITH AT LEAST 2" (51 mm) OF SHORTENING.</b>		
2	Depress, then release the momentary START button	A. RED STARTED lamp and AMBER MELT MODE lamp will light. B. BLUE READY TO START lamp will turn OFF. C. A TIMER in the Default-To-Melt electrical circuit will begin cycling the fryer heat mechanism ON for twelve (12) seconds and OFF for 28 seconds to safely heat the shortening.
<b>CAUTION: CAUTION: PRIOR TO PROCEEDING TO STEP 3, VISUALLY CHECK THAT THE SHORTENING COMPLETELY COVERS THE HEAT MECHANISM.</b>		
3	Depress, then release the momentary Exit Melt button.	A. AMBER MELT MODE lamp will turn OFF and the RED STARTED lamp will remain lit. B. The TIMER in the Default-To-Melt circuit will switch to the FULL ON position, allowing the Electronic Thermostat to heat shortening to it's preset temperature.
4	When the fryers preset temperature has been reached, initiate a cook cycle.	

# ULTRASTAT U25 COOK COMPUTER

## ULTRASTAT 25 COMPUTER with SMS FEATURES

### General

This fryer is equipped with an Ultrastat 25 Cooking computer and a Shortening Management System. These controls are connected to the fryers electrical system to provide heat control, product status and filtering information. When the computer is in operation it will DISABLE the fryer if the drain valve is opened.

### U25 with SMS Control Panel Component Identification

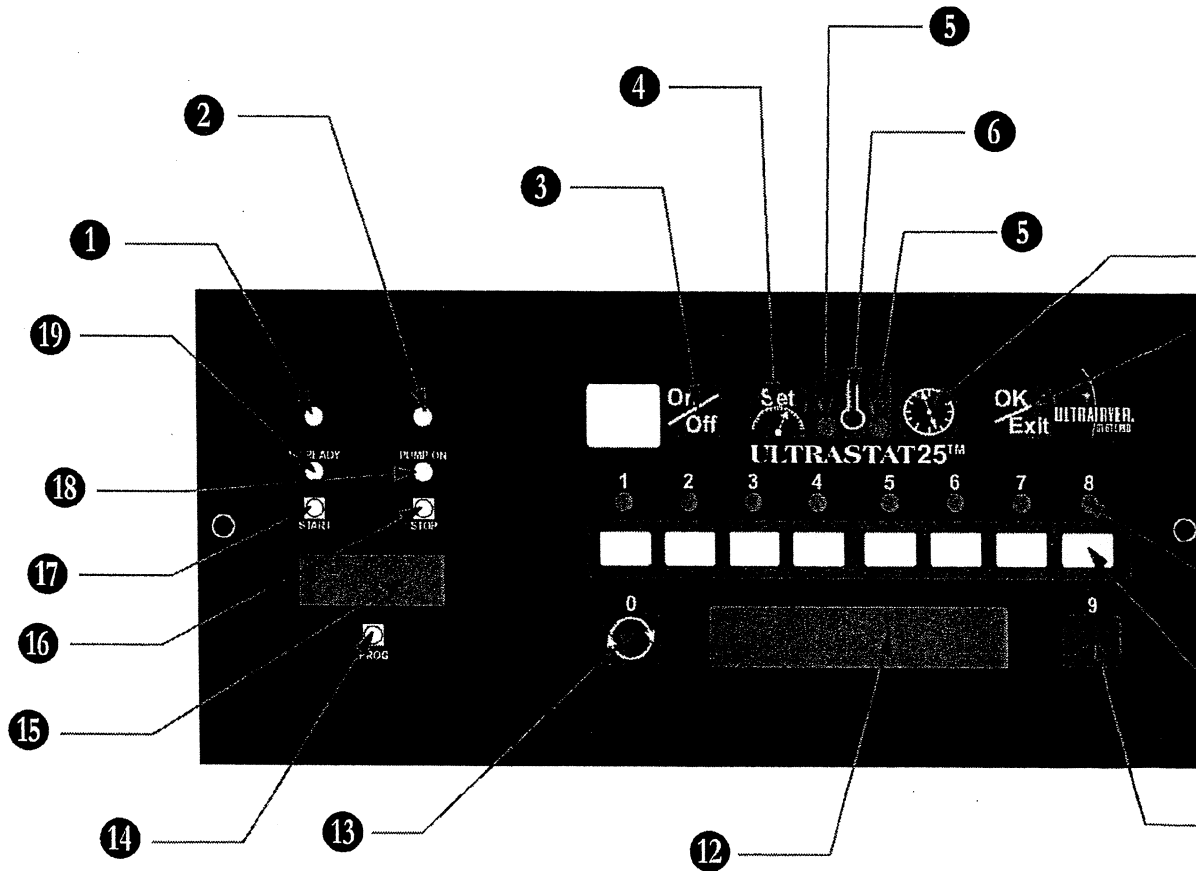

1. **AMBER** Power Indicator Lamp  
When illuminated indicates that electrical power is available to the fryer.
2. **RED** Heating Indicator Lamp  
When illuminated indicates that the heat mechanism is cycling to heat the shortening.
3. On/Off Key  
Turns the computer On and Off when the fryer Toggle Switch is in the ON position and the Drain Valve Lever is in the CLOSED (UP) position.
4. SET Key



- In "Operating" mode, allows access to the programming mode.
  - In "Programming mode, allows access to the operating mode.
5. Heat Demand L.E.D  
When illuminated, indicates the computer is calling for heat.
  6. Temperature Key
    - When depressed one time, displays actual shortening temperature for three (3) seconds.
    - When depressed two (2) times within three (3) seconds, displays current set-point temperature for three (3) seconds.
    - When depressed three (3) times within three (3) seconds, will return to previous display.
  7. Time Key  
Used to display remaining cook time of a product, activate/abort the recipe display of a product, and start the Filter Timer.
  8. OK/Exit Key
    - In "operating" mode, used to manually exit the shortening melt cycle, exit the Filter Timer, and activate/exit the setback mode.
    - In "programming" mode serves as an ACCEPT key.
  9. Product L.E.D
    - When BLINKING fast, in "cooking" mode indicates cooking of that product is in process.
    - When BLINKING slow, indicates cooking of that product is complete.  
**Note:** When several products are in the "cooking" mode and the TIME KEY is pushed, the Product L.E.D of the first to finish will BLINK fast and the other L.E.D's will BLINK slow. When the cook cycle of the "first" product key is complete, its L.E.D will blink FAST and the other product key L.E.D's will turn OFF.
    - When lit BRIGHT in the "programming" mode, indicates that product is being programmed.
  10. Product Cook And Programming Key
    - In "operating" mode, used to start and stop a product cook cycle.
    - In "programming" mode, used to enter numerical values 1 to 8 and to select RECIPE or FEATURES to be programmed.
  11. Programming Key  
Used to enter the numerical value of 9 in "programming" mode.
  12. Display  
Displays modes, functions and operation of the computer.
  13. Toggle/Programming Key
    - In "programming" mode, it is used to enter the numerical value of "0" and "toggle" (switch) between FLEX/STRAIGHT time modes, HIGH/LOW melt release temperature and CELSIUS/FAHRENHEIT temperature units.
    - In "operating" mode, it can be pushed to display the current HIT COUNT and TIME PROMPT.
  14. Programming Button
    - Depress and hold to index filter time options.
  15. SMS Display
    - Displays selected filter options
  16. Stop Button

MODEL 2005 FRYER

- When depressed stops SMS function
- 17. Start Button
  - When depressed initiates SMS function
- 18. Pump On Indicator Light
  - When illuminated indicates the fryer filter pump is in operation.
- 19. SC Ready indicator light
  - When illuminated indicates that the fryer is in the proper configuration for SMS (Wash Wand Lever is in the ON (DOWN) position).

# SHORTENING FILTRATION PROCEDURES

Effective and SAFE shortening filtration is accomplished as follows:

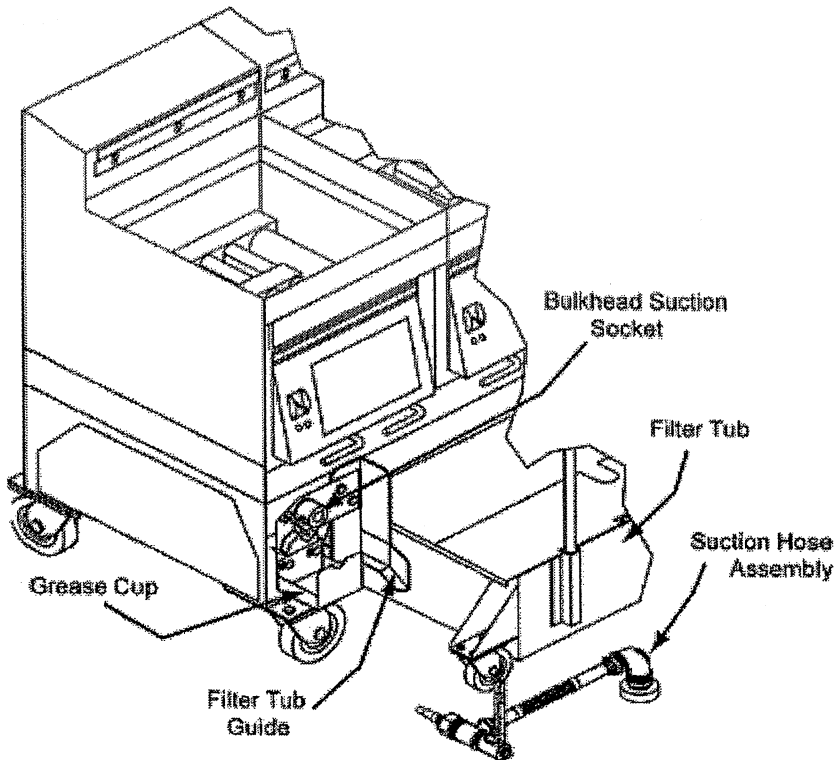

1. Turn the On/Off Switch on the fryer vat to be filtered OFF, place the recommended amount of FILTER AGENT in the fryer vat; thoroughly stir the filter agent into the shortening using the skimmer, then skim the shortening to remove any floating crumbs.

**Attention:** PRIOR TO PROCEEDING TO THE NEXT STEP, DON SAFETY GOGGLES, NEOPRENE INSULATED GLOVES AND AN APRON

2. Carefully open the drain valve on the vat to be filtered by turning the DRAIN LEVER slightly downward. When the bottom of the filter tub is covered with about 2" (51 mm) of shortening, OPEN the drain valve and slowly drain shortening to allow the heat mechanism to gradually COOL.
3. When all shortening in the vat has drained into the filter tub, use the DRAIN ROD to stand the wire rack on one side of the vat.
4. Use the drain rod to break up the sediment caked on the bottom of the vat and to pull the sediment toward and into the drain valve opening.
5. Use a scraper to remove encrusted material from the sides of the vat and a stropping pad to remove carbon buildup from the top and sides of the heat mechanism.
6. SECURELY connect the Wash Down Hose female QUICK-CONNECT FITTING to the male QUICK-CONNECT STEM on the rear wall of the vat.

**Danger:** IF THE FITTING IS NOT SECURELY ATTACHED TO THE STEM, HOT SHORTENING WILL BE DISCHARGED AROUND THE CONNECTION WHICH COULD CAUSE SEVERE BURNS

7. Place the Wash Down Hose nozzle into the fryer and hold it firmly against an inner wall. This prevents the hose from "recoiling upward" when the filter pump is turned on.
8. Turn the PUMP LEVER to the open (DOWN) position, hold the nozzle at a 45° angle from the bottom of

the fryer so as to cause shortening and debris to bounce off the rear wall of the vat and flow towards the drain valve opening.

9. Use the "L" shaped vat brush to push the sediment through the drain valve to keep the drain clear. Hose off the burner tubes and all walls of the vat until all the shortening and residue at the bottom of the fryer has been flushed through the drain into the filter tub.
10. Turn the PUMP LEVER to the closed (UP) position, disconnect the Wash down hose FITTING from the STEM on the rear wall of the vat; then hang the Wash Down hose in an upright position so shortening can drain into the container.

**Note:** Failure to hang the Wash Down hose in an upright position to drain may cause the hose to become clogged with hardened shortening.

11. Replace the wire grill in the fryer with the shortening DEFLECTOR on the RIGHT COVERING the quick-connect stem on the vat.

## Wash Wand Operation

The pump activation switch is located under the controller panel on the right side. The switches located under Vat# 2 and Vat# 5 operate independently of each other.

Figure. Filtration handles (in closed position)

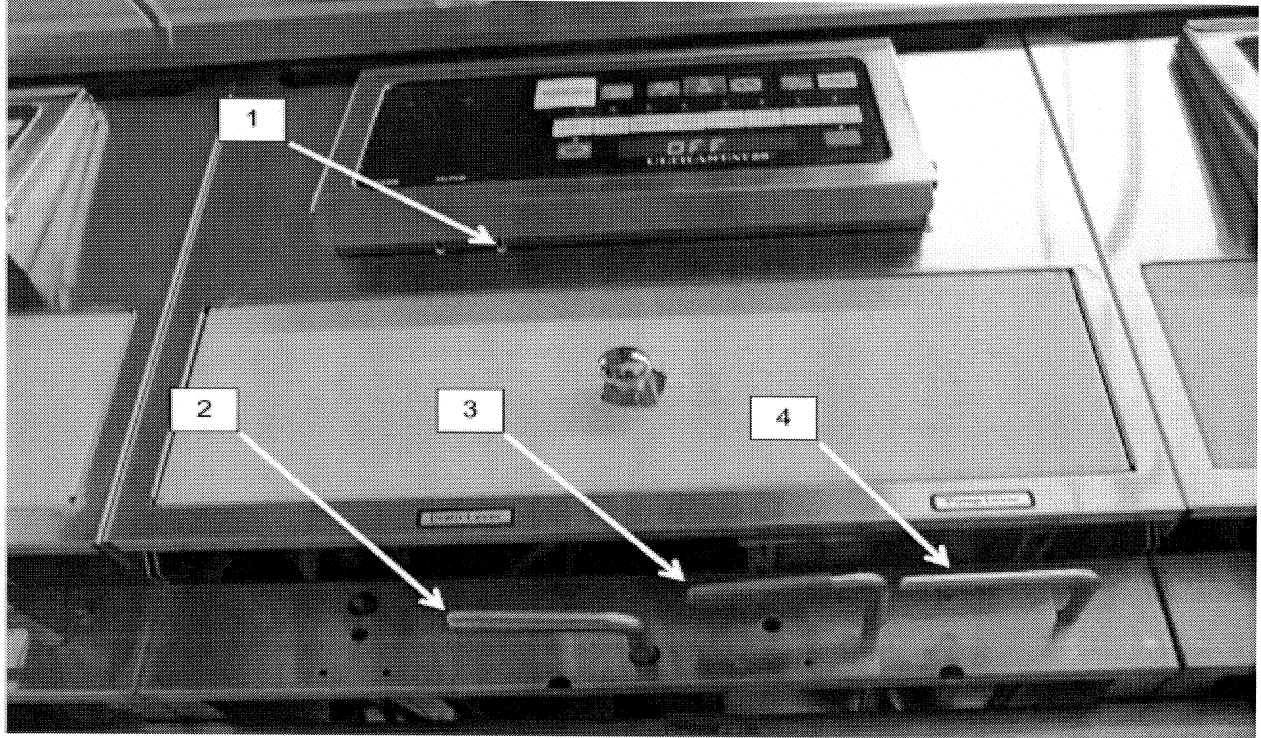

**CAUTION: Handles may be HOT.**

1. **Pump Activation Switch:** Activates the pump to the **Wash Wand**. (The switches located under Vat#2 and Vat#5 operate independently of each other.)

**Note:** The **Wash Wand (Red) Handle** must also be in the "open" position for Wash Wand operation.

2. **Drain Lever:** Operates the main drain valve, which drains the shortening from the vat to the drain trough.
3. **Wash Wand (Red) Handle:** Causes shortening to flow into the Wash Wand.

**Note:** The **Pump Activation Switch** must also be turned on for Wash Wand operation.

**CAUTION: Wash Wand and shortening are HOT.**

4. **Vat Return Pump Lever:** Turns on the pump and returns the oil from the filter tub to the vat.

---

# POLISHING SHORTENING

Follow the following procedures to polish shortening:

1. With the Drain valve still OPEN, set a timer for the amount of time established for POLISHING shortening, then turn the PUMP LEVER to the open (DOWN) position to allow shortening to circulate through the system to POLISH the shortening.

**Caution:** DO NOT POLISH THE SHORTENING MORE THAN THE ESTABLISHED TIME AS IT WILL AERATE THE SHORTENING CAUSING IT TO BREAKDOWN

2. At the end of the established time, TURN the PUMP LEVER, and the DRAIN LEVER to the closed (UP) position, then TURN the PUMP LEVER to the open (DOWN) position to automatically return shortening in the filter tub to the fryer vat.
3. When all shortening has been returned to the fryer, turn the PUMP LEVER to the closed (UP) position; check and if necessary, add fresh shortening to the vat until it is at it's proper level.
4. Repeat steps 1 through 11 in the SHORTENING FILTRATION PROCEDURES section and steps 1 through 3 to filter and polish shortening in the remaining fryer vats.
5. Once the last vat has been FILTERED and POLISHED, disconnect the Wash Down hose fitting from the STEM on the rear wall of the vat and hang the hose in an UPRIGHT position to drain any residual shortening into a container.
6. Disconnect the suction line hose male QUICK-CONNECT plug from the fryer's BULKHEAD SUCTION coupler, remove the filter tub from beneath the fryer by grasping it's handle and disconnect the suction line hose from the filter screen STANDPIPE. Thoroughly clean and reinstall the filter tub and suction line hose assembly.

**Caution:** DO NOT USE THE STANDPIPE OR SUCTION LINE HOSE ASSEMBLY TO PULL THE FILTER TUB FROM BENEATH THE FRYER, TO DO SO WILL DAMAGE THE FILTER SCREEN

7. Turn the PUMP LEVER to the closed (UP) position and resume normal operation.

# SHORTENING DISPOSAL

Dispose of shortening as follows:

1. If not already accomplished, assemble the filter Tub as described earlier, SECURELY connect the Suction Line Hose female quick-connect fitting to the Filter Screen STANDPIPE, insert the Filter Tub beneath the fryer; then SECURELY connect the MALE plug on the Suction Line Hose to the fryers BULKHEAD Suction Coupling.
2. Turn the fryers ON/OFF switch and the MANUAL GAS VALVE to the first vat OFF

**Attention:** PRIOR TO PROCEEDING TO THE NEXT STEP, DON SAFETY GOGGLES, NEOPRENE INSULATED GLOVES AND AN APRON

3. Turn the Vent hood Exhaust Fan ON and drain shortening from the fryer as described in the SHORTENING FILTRATION section.
4. To dispose of shortening, Proceed as follows:

## Disposal System.

- a. Connect the Wash Down hose female QUICK-CONNECT fitting to the male QUICK-CONNECT stem on the rear wall of the vat, place the hose nozzle into a METAL container and hold it firmly against the inner wall.
- b. Turn the PUMP LEVER to the open (DOWN) position and pump shortening in the Filter Tub into the METAL container.
- c. Repeat the steps in 1. & 2. above to remove and dispose of shortening in the remaining vats.
- d. Once all shortening in the filter tub has been pumped into the metal container, turn the PUMP LEVER to the closed (UP) position, disconnect the Wash Down hose FITTING from the STEM on the rear wall of the vat; replace the wire grill in the fryer with the shortening DEFLECTOR on the right COVERING the QUICK-CONNECT vat stem; then hang the Wash Down hose in an upright position so residual shortening can drain into a container.

**Note:** Failure to hang the Wash Down hose in an upright position to drain may cause the hose to become clogged with hardened shortening.

## Disposal System.

- a. SECURELY connect the SHORTENING DISPOSAL SYSTEM hose fitting to the QUICK-CONNECT stem on the rear wall of the vat and connect the fitting on the other end of the hose to the disposal system connector on the wall.
- b. Turn the PUMP LEVER to the open (DOWN) position and pump shortening from the filter tub into the EXTERIOR RENDERING TANK.
- c. Repeat the steps in 1. & 2. above to remove and dispose of shortening in the remaining vats.
- d. Once the shortening has been removed from all fryers, turn the PUMP LEVER to the closed (UP) position, remove the shortening disposal hose from the disposal system connector on the wall and from the fryer vat stem; then hang the disposal hose in an upright position so shortening can drain into a container.

**Note:** Failure to hang the Wash Down hose in an upright position to drain may cause the hose to become clogged with hardened shortening.

5. When shortening has been removed from all fryer's, THOROUGHLY clean and reinstall the filter tub assembly.

# FRYER BOIL OUT PROCEDURES

Fryer vats should be BOILED-OUT at least every 7 DAYS to remove carbon build up and other encrusted materials. BOIL-OUT each fryer following cleaning instructions contained in the Cleaning Manual provided by your approved chemical supplier. The following are generic procedures:

1. Ensure all Drain Levers are in the closed (UP) position, then add water to each vat until it reaches a point two 2" (51 mm) BELOW the middle line of the "E" in the word LEVEL of the UPPER level mark on the rear wall of the vats.

**Caution:** ONLY USE A COMMERCIAL "NON-CHLORINE" BOIL-OUT COMPOUND

2. Add the amount of BOIL-OUT COMPOUND in each fryer vat as prescribed in the Cleaning Manual provided by the Chemical Supplier.
3. Turn the fryers On/Off Switch and manual Gas Valve for the fryer to the ON position, momentarily depress the START and then the EXIT MELT buttons on the DTMR.
4. When the boil-out solution starts to BOIL set a timer for 30 minutes and frequently scrub the sides, front and back of the vat with a long handled scrub brush.
5. While the fryer is being BOILED OUT, clean the filter tub assembly according to procedures in the CLEANING section.

**Note:** If the boil-out solution starts to boil over, shut the fryer OFF for a few minutes and add water as necessary, then turn it back ON.

6. When the timer sounds, turn the fryer's ON/OFF Switch and Manual Gas Valve for the fryer to the OFF position; then CAREFULLY dispose of the boil-out solution in the fryer in a floor drain.

**Caution:** DO NOT USE THE PUMP/MOTOR UNIT TO REMOVE WATER FROM THE FRYER. THIS WILL CAUSE PREMATURE PUMP FAILURE AND VOID THE WARRANTY

7. Use a scrubbing pad to remove carbon buildup from the top of the burner. To remove carbon buildup on the sides and bottom of the heat exchanger, slide one end of a stropping pad under each heat exchanger, grasp that end with a pair of tongs and rock the pad up and down along the length of each heat exchanger until all encrusted material has been removed. Replace the wire rack in the fryer.
8. Rinse the fryer with hot water until the water coming out of the drain valve is clear.
9. Mix a solution of ONE PART vinegar to 25 PARTS of water. Place this mixture into a one-gallon garden pressure sprayer and THOROUGHLY spray this solution onto the SIDES, BURNER TUBES and BOTTOM of the fryer to neutralize the Boil Out Compound.

> **[Important]** : Boil-Out Compound will cause shortening to break down rapidly if it is not neutralized.

10. THOROUGHLY wipe the sides, burner tubes and bottom of the fryer with clean, lint-free, dry towels to remove any remaining water, turn the DRAIN VALVE to the closed UP position; then fill the fryer with NEW shortening to the shortening level mark as described in the following section.



## FILTER TUB ASSEMBLY & INSTALLATION

### General

This fryer is equipped with a portable Filtration System which is located on a Filter Tub Caddy beneath the typically, on the left side of the fryer as shown below. The On/Off toggle switch, *AMBER POWER* and *RED BURNER* Indicator Lamps are located on the Controller Door assembly. Other controls, as well as the gas valves are accessed behind this Service access door. The Drain Levers are located beneath the Service access door.

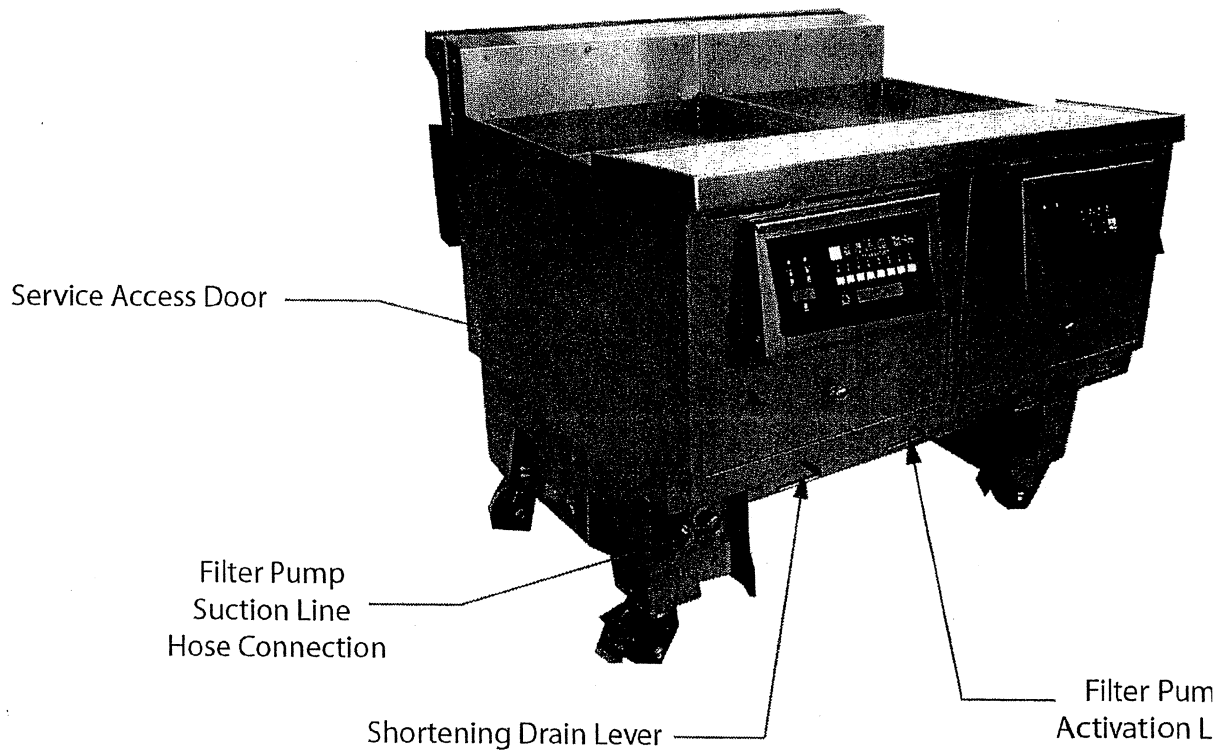

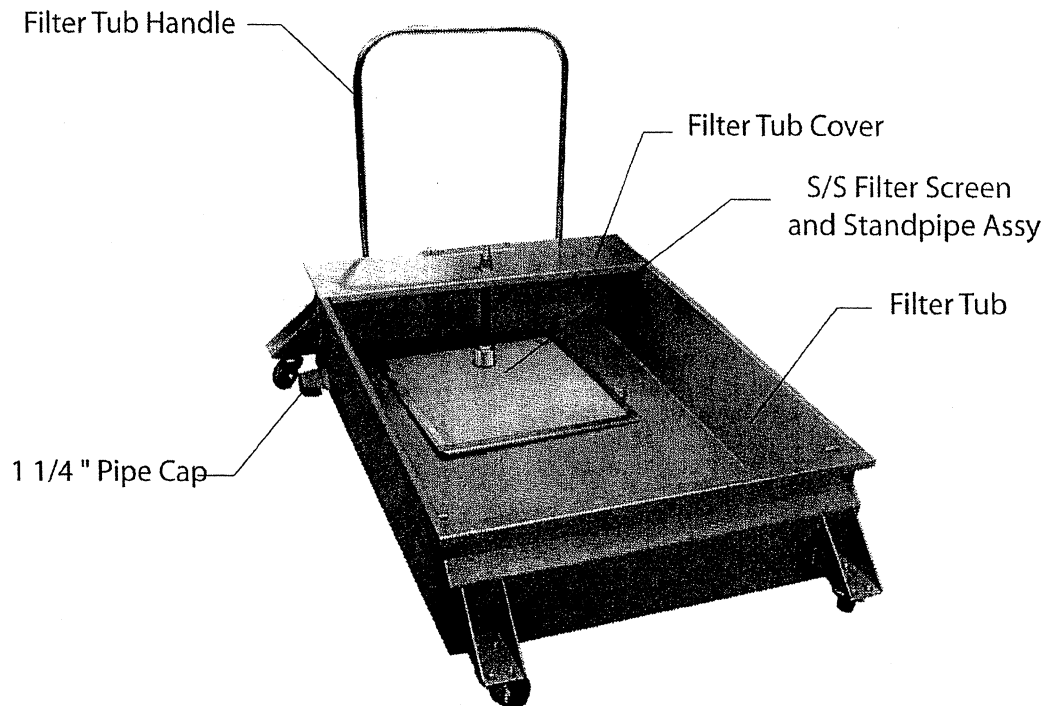

#### Filter Tub Assembly

Assemble the Filter Tub as follows:

1. Make sure the FILTER TUB, HANDLE and COVER; SUCTION LINE HOSE, and FILTER ASSEMBLY are clean and dry.
2. Reassemble the Filter Tub by replacing the components in the following sequence:  
1) FILTER ASSEMBLY, 2) COVER, 3) SUCTION LINE HOSE and 4) FILTER TUB HANDLE.

**CAUTION:** WHEN ASSEMBLED, ENSURE THERE ARE NO FINGER LOOPS ON THE STANDPIPE SIDE OF THE MICRO-MESH FILTER.

#### Filter Tub Installation

Install the Filter Tub as follows:

1. CAREFULLY insert the Filter Assembly in the bottom of the Filter Tub with the STANDPIPE centered in the handle end of the tub.
2. Place the cover on the Filter Tub; then install the Handle on the Filter Tub.
3. Install the Suction Line Hose FEMALE Quick-Connect fitting to the MALE Quick-Connect fitting on the filter screen STANDPIPE, insert the Filter Tub on the FILTER TUB GUIDES beneath the LEFT side of the fryer until it contacts the STOP bracket; then connect the MALE plug on the Suction Line Hose Assembly to the Bulkhead Suction Socket on the Fryer.
4. Refer to the FILTERING SHORTENING procedures in this manual, for shortening filtration.

## CLEANING

### General

As mentioned earlier, Any item of equipment operates better and lasts longer when it is kept cleaned and properly maintained, and the FRYER and FILTER TUB ASSEMBLY are no exception. Clean the FILTER SCREEN after Filtering Shortening and at Closing; and THOROUGHLY clean the FILTER TUB ASSEMBLY each DAY and WEEK as described below.

### Daily

Clean the Filter Machine and Filter Assembly after FILTERING and AT CLOSING as follows:

1. Disassemble the Filter Machine by removing the following items in the order listed:  
(1) FILTER TUB HANDLE, (2) COVER, (3) WASH DOWN HOSE, (4) SUCTION LINE HOSE, and (5) FILTER ASSEMBLY.
2. Clean the Suction Line Hose and Wash Down Hose with sanitizer solution; then hang these hoses in an upright position so any shortening can drain into a container.
3. Raise the Filter Assembly above the Filter Tub and let any sediment or shortening drain into the tub; then THOROUGHLY clean the filter assembly as follows:

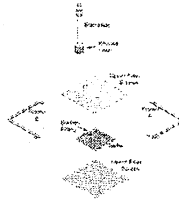

### Micro-Mesh Stainless Steel Filter Screen

- a. CAREFULLY remove any debris from the screen using a scraper.
- b. Remove the STANDPIPE and KNURL knob from the FILTER SCREEN assembly, grasp the FINGER LOOP on FRAME A and adjacent FINGER LOOP on FRAME B, EVENLY pull the frames apart; then HINGE FRAME A to remove it from the FILTER SCREENS FIRST.
- c. Grasp the FINGER LOOP on the straight side of FRAME B; then HINGE it to remove FRAME B from the FILTER SCREENS.
- d. Separate the UPPER FILTER SCREEN and BAFFLE from the LOWER FILTER SCREEN.
- e. CAREFULLY clean the two frames, screens and baffle in a 3 compartment sink with hot water and allow these items to air dry. **DO NOT USE SOAP**. If necessary the channels in each frame can be cleaned with the edge of a scotch-brite pad.
- f. Insert the SUCTION FITTING on the BAFFLE in the hole of the UPPER FILTER SCREEN; then place these items on top of the LOWER FILTER SCREEN.
- g. ENSURE all sides of the FILTER SCREEN assembly are aligned, place the PIN end of FRAME A on the FILTER SCREENS, place the CHANNEL on the frame adjacent to the PIN end over the FILTER SCREENS; then HINGE the frame so the edge of the FILTER SCREENS are inserted in the other CHANNEL of FRAME A.
- h. Place the PIN end of FRAME B on the FILTER SCREENS so the PIN is seated in the CHANNEL of FRAME A near the FINGER LOOP, place the CHANNEL on the frame adjacent to the PIN end over the edge of the FILTER SCREENS; then HINGE the frame so the edge of the FILTER SCREENS are inserted in the

other CHANNEL of FRAME B and the PIN of FRAME A is seated in the CHANNEL of FRAME B .

- i. Adjust FRAME A and B so both PINS are properly seated in the CHANNEL of the opposite frame; then CAREFULLY connect the KNURL KNOB and STANDPIPE to the SUCTION FITTING on the FILTER SCREEN assembly. **DO NOT OVERTIGHTEN!**
4. Remove any sediment and shortening in the Filter Tub using a scraper; then wipe the tub dry with paper towels.
5. Carefully insert the Filter Assembly in the bottom of the Filter Tub with the STANDPIPE centered in the handle end of the tub.  
**Note: CAUTION:** WHEN ASSEMBLED, ENSURE THERE ARE NO FINGER LOOPS ON THE STANDPIPE SIDE OF THE FILTER.
6. SECURELY connect the FEMALE fitting on the Suction Line Hose to the MALE stem on the Filter Screen STANDPIPE, install the assembled Filter Tub beneath the fryer until it is butted against the STOP bracket; then connect the MALE plug on the Suction Line Hose to the fryers FEMALE Bulkhead Socket shown to the right.

### Weekly

Perform the following steps Weekly to maximize product quality and equipment operation:

1. Disassemble the Filter Machine by removing the following items in the order listed:  
(1) FILTER TUB HANDLE, (2) COVER, (3) WASH DOWN HOSE, (4) SUCTION LINE HOSE, and (5) FILTER ASSEMBLY.
2. Clean the Suction Line Hose and Wash Down Hose with sanitizer solution; then hang these hoses in an upright position so any shortening can drain into a container.
3. Raise the Filter Assembly above the Filter Tub and let any sediment or shortening drain into the tub; then THOROUGHLY clean the filter assembly as follows:

#### Micro-Mesh Stainless Steel Filter Screen

- a. CAREFULLY remove any debris from the screen using a scraper.
- b. Remove the STANDPIPE and KNURL knob from the FILTER SCREEN assembly, grasp the FINGER LOOP on FRAME A and adjacent FINGER LOOP on FRAME B, EVENLY pull the frames apart; then HINGE FRAME A to remove it from the FILTER SCREENS FIRST.
- c. Grasp the FINGER LOOP on the straight side of FRAME B; then HINGE it to remove FRAME B from the FILTER SCREENS.
- d. Separate the UPPER FILTER SCREEN and BAFFLE from the LOWER FILTER SCREEN.
- e. Place the upper and lower FILTER SCREENS in the fryer with BOIL-OUT SOLUTION for cleaning. **DO NOT PLACE THE BAFFLE OR STANDPIPE IN THIS SOLUTION!** BOIL-OUT the fryer vat according to instructions contained in the cleaning manual provided by your chemical supplier.
- f. After the filter screens have been cleaned in the Boil-Out Solution, ENSURE they are THOROUGHLY sprayed with a solution of 1 PART vinegar to 25 PARTS of water to NEUTRALIZE the boil-out solution, then allow the screens to air dry.  
**Note:** Any residue of boil-out solution on the filter screens could cause the rapid breakdown of the shortening.
- g. Insert the SUCTION FITTING on the BAFFLE in the hole of the UPPER FILTER SCREEN; then place these items on top of the LOWER FILTER SCREEN.
- h. ENSURE all sides of the FILTER SCREEN assembly are aligned, place the PIN end of FRAME A on the FILTER SCREENS, place the CHANNEL on the frame adjacent to the PIN end over the FILTER SCREENS; then HINGE the frame so the edge of the FILTER SCREENS are inserted in the other CHANNEL of FRAME A.

- i. Place the PIN end of FRAME B on the FILTER SCREENS so the PIN is seated in the CHANNEL of FRAME A near the FINGER LOOP, place the CHANNEL on the frame adjacent to the PIN end over the edge of the FILTER SCREENS; then HINGE the frame so the edge of the FILTER SCREENS are inserted in the other CHANNEL of FRAME B and the PIN of FRAME A is seated in the CHANNEL of FRAME B .
  - j. Adjust FRAME A and B so both PINS are properly seated in the CHANNEL of the opposite frame; then CAREFULLY connect the KNURL KNOB and STANDPIPE to the SUCTION FITTING on the FILTER SCREEN assembly. **DO NOT OVERTIGHTEN!**
4. THOROUGHLY clean the Filter Tub and Cover with HOT SANITIZER SOLUTION and allow them to air dry.
  5. Carefully insert the Filter Assembly in the bottom of the Filter Tub with the STANDPIPE centered in the handle end of the tub.  
**Note: CAUTION: WHEN ASSEMBLED, ENSURE THERE ARE NO FINGER LOOPS ON THE STANDPIPE SIDE OF THE FILTER.**
  6. SECURELY connect the FEMALE fitting on the Suction Line Hose to the MALE stem on the Filter Screen STANDPIPE, install the assembled Filter Tub beneath the fryer until it is butted against the STOP bracket; then connect the MALE plug on the Suction Line Hose to the fryers FEMALE Bulkhead Socket shown to the right.

# Preventive Maintenance and Troubleshooting

## Preventive Maintenance

Minimal maintenance is required on the fryer because of its design and the materials used in the manufacturing process. However, some preventive maintenance and inspection must be performed periodically to prevent break downs which could curtail food sales. Any preventive maintenance or inspection should be accomplished with **CAUTION** while the fryer is in operation since HOT liquid shortening could cause severe burns. If service or repair is required, all gas and electric power **MUST BE TURNED OFF PRIOR** to performing any service or repair. The following chart describes the minimum items to be inspected and the inspection interval:

### Preventive Maintenance Inspection Schedule

Item	Inspection Description
<b><u>Daily</u></b>	
Grease Filters	Clean grease filters in the exhaust hood each evening and allow them to dry overnight.
Filter Tub	Thoroughly clean the filter tub assembly prior to leaving the store at closing.
<b>NOTE:</b> Ensure the wash down hose is hung in an upright position (by one end) so shortening can drain into a container.	
<b><u>Weekly</u></b>	
Drain / Filter Pump Valve Levers	Determine that all levers are securely attached and that they can be easily opened and closed.
Drain Hoses	Inspect the suction line, wash down and if applicable, the shortening disposal hose for any evidence of deterioration.
Plumbing Heat Tape	Ensure that the insulation and electric heat tape that are wrapped around the plumbing directly behind the drain trough has not been damaged.
Temperature Sensing Probes	During boil-out of the fryer, inspect the temperature and high limit sensing probes for any visual damage.



<b><u>Semiannually</u></b>	
Agitator Baffle	A qualified technician or authorized service agent is to remove and inspect the agitator baffle in each fryer for metal fatigue or weld deterioration every SIX (6) MONTHS. If no defect is found, reinstall the original baffle.
<b>NOTE:</b> Slight warp or a few broken fins is normal wear. DO NOT REPLACE during semiannual inspection.	
<b><u>Annually</u></b>	
Agitator Baffle	A qualified technician or authorized service agent is to install a NEW agitator weldment in each fryer AUTOMATICALLY every TWELVE (12) MONTHS.

# Troubleshooting

## General

The problems and possible solutions listed in the troubleshooting chart below are typical problems that are frequently encountered. **ONLY** qualified repairmen are to use the troubleshooting chart to repair this fryer. In the event a main burner malfunction occurs, perform the following checks **PRIOR** to contacting a repairman:

- Ensure Gas Valves are in their proper positions.
- Check that the fryer electrical plug is connected to an electrical receptacle.
- Ensure the applicable Circuit Breaker is in the ON position and that the fryer ON/OFF switch is in the ON position.
- Ensure the applicable fryer control has been placed in the FULL ON mode.
- Ensure the gas supply line quick-disconnect coupling is SEATED on the gas manifold fitting.
- Determine that the blower is operating.

### Basic Troubleshooting Chart

Problem	Possible Solution
Main burner will not ignite.	<ol style="list-style-type: none"><li>1. Check the Blower Air Pressure Switch by temporarily disconnecting the two ORANGE air switch wires and connecting them together. If the IGNITOR sparks when these wires are connected, the air pressure switch is defective and will have to be replaced.</li><li>2. Check the following components and replace if found to be defective:<ol style="list-style-type: none"><li>a. Gas Control Valve</li><li>b. High Limit Switch</li><li>c. Transformer</li></ol></li></ol>
The fryer is receiving electrical power, but the blower is not operating.	The blower may have overheated and shut off automatically. If this did occur, the situation will correct itself when the motor cools (10-20min). If overheating problems persist, replace the blower motor.
Excessive time is required to raise the shortening to cooking temperature. Temperature recovery is slow, and main burner flames are small and appear low.	<ol style="list-style-type: none"><li>1. Ensure that the MANUAL GAS VALVE is completely open.</li><li>2. High Limit Switch Check for an obstruction in the gas line.</li><li>3. Check for an obstruction in the flue pipe.</li><li>4. Check that the ORIFICE PLUG has the correct drill size opening as indicated on the operational requirements chart.</li><li>5. Check for damaged BLOWER fins.</li><li>6. Use a standard water-type U gauge Manometer to check the pressure at the gas control valve pressure tap. Proper gas pressure is indicated on the operational requirements chart.</li></ol>
<b>NOTE:</b> If necessary, remove the Pressure Regulator Adjustment Cover and adjust this control to the proper pressure. (Turn adjusting screw CLOCKWISE to increase gas pressure to the burner and COUNTER CLOCKWISE to decrease gas pressure. Replace adjustment cover.)	

**Basic Troubleshooting Chart (continued)**

<b>Problem</b>	<b>Possible Solution</b>
Shortening temperature is too high and breaks down quickly.	<ol style="list-style-type: none"><li>1. Check the gas pressure as described above.</li><li>2. Check calibration of the Electronic Thermostat with an accurate digital thermometer.</li></ol>
The filter pump motor fails to operate when the Vat Shortening Return / Topside Shortening Lever is placed in the OPEN position.	<ol style="list-style-type: none"><li>1. Ensure the filter pump micro-switch is good, then check the manual reset button on the filter pump motor.</li><li>2. If the filter pump motor fails to operate after the reset button has been depressed, then the motor needs to be repaired or replaced.</li></ol>
Decreased shortening flow rate while filtering.	Check for excessive sediment on the filter screen, in the standpipe suction fitting, or in the filter tub.
Pump / Motor operates but does not pump shortening.	<ol style="list-style-type: none"><li>1. Check for congealed shortening in the shortening system.</li><li>2. Check for loose standpipe / suction line coupler connection.</li></ol>
Pump / Motor hums but will not pump shortening.	Check for congealed shortening in the pump or in shortening plumbing.



## ELECTRONIC THERMOSTAT CALIBRATION

### General

This fryer is equipped with a Default-to-Manual-Restart (DTMR) Control and an Electronic Thermostat to control cooking temperatures. The fryers are tested, adjusted and calibrated prior to being shipped: however adjustments may be necessary on installation to meet local conditions, high or low gas pressure, differences in altitudes, variations in gas characteristics and to correct possible problems caused by rough handling or vibration during shipment. If adjustment is necessary, it can be accomplished as follows:

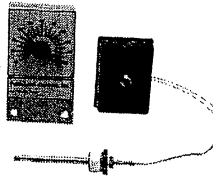

### Electronic Thermostat Calibration Procedures

1. ENSURE electrical power and, if applicable, gas to the fryer has been turned OFF.
2. CAREFULLY drain sufficient shortening from the fryer to LOWER the shortening about 4" (102 mm) beneath the Electronic Thermostat sensing probe.
3. After the sensing probe has COOLED, loop the Sensing Element of an ACCURATE digital test thermometer temperature probe around the sensing element; then connect the probe to the test thermometer.
4. Replace shortening drained in step 2. and ENSURE it is level with the shortening level mark on the rear of the vat; then turn the power and, if applicable, gas to the fryer ON.
5. Set the KNOB of the Electronic Thermostat to the CENTER (300) of the dial and periodically STIR the shortening in a COUNTERCLOCKWISE (CCW) direction with a long handle skimmer to pull congealed shortening UPWARD from the Cold Zone area.
6. When shortening has reached the set temperature and the RED indicator lamp on the fryer has turned OFF, allow the Electronic Thermostat to cycle ON and OFF about five (5) times to stabilize the system.
7. After the shortening temperature has stabilized, record the temperature reading of the TEST THERMOMETER immediately after the RED indicator lamp and the fryer turns OFF.
8. CAREFULLY loosen the set screw on the Electronic Thermostat KNOB without turning the thermostat potentiometer, set the thermostat knob pointer to the temperature recorded by the test thermometer; then tighten the set screw on the thermostat knob taking care not to turn the thermostat's potentiometer.
9. Repeat steps 1. and 2. above, remove the test thermometer temperature probe from the Electronic Thermostat sensing element; then repeat step 4 to return the fryer to normal operation.

# Technical Assistance and Parts Ordering Information

## Technical Assistance

Model BP30-14/18/20

Contact an authorized service agent or the Customer Service Department, Ultrafryer Systems at **1.800.525.8130** for technical assistance.

## Parts Ordering Information

### *Replacement Parts*

To expedite requests and minimize downtime, please provide the following information when ordering replacement parts by phone, fax or mail:

- Your company name and phone number
- Your company purchase order number
- Bill-to address
- Ship-to address
- Part number and description of the desired item
- Quantity desired
- Your name or signature of authorized buyer

To order via Telephone:



(888) 331-5031

To order via Fax:



(210) 731-5099

Please indicate “*ATTN: Order Entry Department*” on the FAX cover sheet to ensure timely processing of your order.

To order via Mail:



Ultrafryer Systems  
ATTN: Order Entry Department  
PO Box 5369  
San Antonio, TX 78201

To order via Email:



[ultrafryerservice@ultrafryer.com](mailto:ultrafryerservice@ultrafryer.com)

## **Terms**

Net 30 days for customers on open accounts. Past due balances will be charged 1 1/2% per month (18% per annum) until full balance is paid.

## **Damages**

Ultrafryer Systems is not responsible for damage occurring in transit. All deliveries must be inspected for damage to shipping containers prior to departure of the delivering carrier. Any damage must be notated on the receiving document to facilitate filing of freight claims. Carriers must be notified immediately and freight inspections must be requested from the carrier. Ultrafryer Systems can and will gladly assist you in preparing and processing of the necessary claims only if proper notification has been accomplished on the carrier delivery document. Damaged equipment and or containers must be available for the claims inspector to inspect.

## **Returns**

Ultrafryer Systems cannot guarantee credit for items returned without proper authorization. All returns must have prior Ultrafryer Systems Customer Service or Warranty department approval. An assigned number will be issued by the approval authority. Please print the assigned number on all returned packages and corresponding paperwork. Returned goods are subject to a 15% restocking charge. Ultrafryer Systems is not responsible for freight charges on returned goods unless authorized by Customer Service and or Warranty personnel. Ultrafryer Systems does not receive freight collect or C.O.D. shipments.

RECOMMENDED SPARE PARTS

## RECOMMENDED SPARE PARTS

Ultrafryer systems prides itself on the continued reliability of our products. However, as with all electronic/mechanical devices, after time it is reasonable to expect a small amount of unscheduled repairs/parts replacement. The following table lists the minimum spare parts that should be kept on hand, should the need arise, to reduce the amount of fryer downtime.

Table1. BP30-18/14 Gas Fryer Recommended Spare Parts

BP30-18/14 Gas Fryer Recommended Spare Parts	
Description	UFS P/N
Spark Ignitor Module	18179
Spark Ignitor Rod Assembly - BP20 > <b>[Important]</b> : Set Rod Gap To 5/32" (4 mm).	12A043
Spark Ignitor Rod Assembly - BP30 > <b>[Important]</b> : Set Rod Gap To 5/32" (4 mm).	19A738
Ignitor Rod Cable w/Plugs	18187
Hi-Limit Switch - Preset To Trip at 400°F (204°C)	19A144
120 Volt To 24 Volt Step-down Transformer	18180
24 Volt Combination Gas Control Valve	18227
120 Volt SPDT (Single Pole, Double Throw) Toggle Switch	18A287
Air Pressure Switch	18A291
1/3 HP Class H 115 Volt 60 Hz Motor	17A018
7.7 GPM (29.26 LPM) Pump - For Fryer Banks Containing 18" & 20" Vats.	24329
5.5 GPM (29.26 LPM) Pump - For Fryer Banks Containing ONLY 14" Vats.	24339
1/4" (5 mm) Compression Fitting	24247

120V.

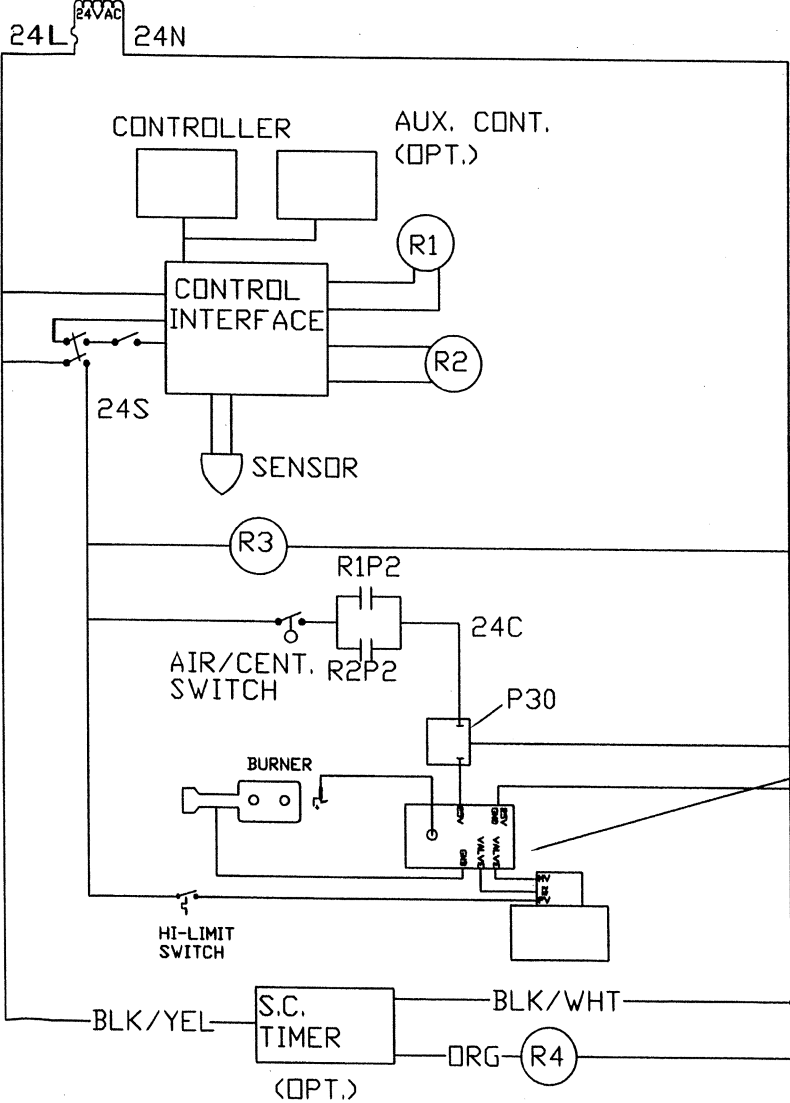
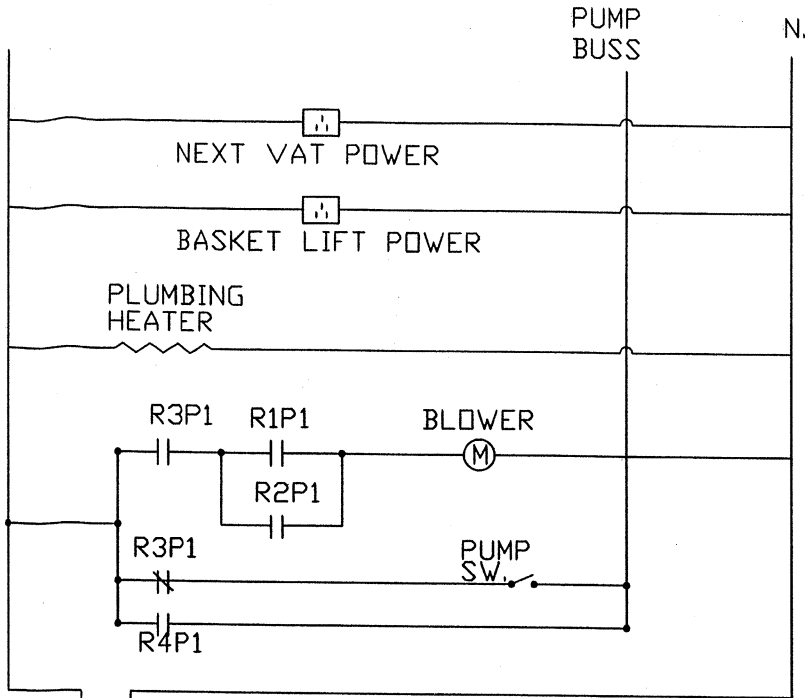

THIS DECAL IS LOCATED ON THE FAR RIGHT SIDE BACK PANEL FROM FRONT

