

Project: \_\_\_\_\_

Item: \_\_\_\_\_

Quantity: \_\_\_\_\_

## Slicer Stand



Mobile Slicer Stands are dual purpose carts designed to hold equipment and transport trays or pans simultaneously. When slicing, pans are held at a workable height by the built-in retractable shelf.

This versatile workstation saves counter space and can be moved throughout the kitchen or foodservice facility. Four 5" plate type swivel casters, all with total lock, eliminate all movement while slicing.

Retractable 16 GA Stainless Steel Pull-Out Shelf & Top Bracing



- Base is reinforced at each corner with a threaded plate, casters are bolted to these slabs – not the framework. This provides additional strength and stability to the rack, prevents structural damage to the framework, and makes caster replacement easier.
- All-welded aluminum construction using primary grade aluminum.
- Solid top and retractable shelf are constructed out of 16-gauge stainless steel.
- Equipped with four 5" plate type swivel casters, with total lock to eliminate all movement.
- Lifetime Guarantee against rust and corrosion.
- Five-Year Guarantee against workmanship and material defects.

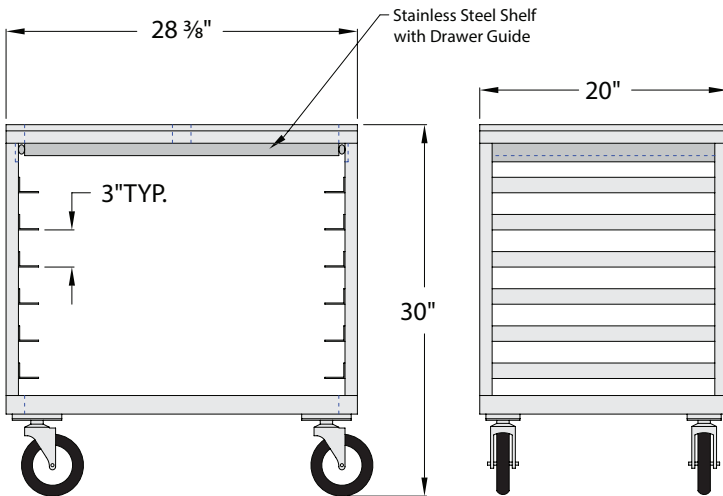

### ► Slicer Stand

Model No.	Size W-H-D	Runner Spacing	Pan Capacity	Ship Lbs.
99217	28 <sup>3</sup> / <sub>8</sub> " x 30" x 20"	3"	6	67

Four 5" plate type swivel casters with total locks.

**OPTIONS:** Options may not be NSF Certified. Contact the factory.

- Cord Wrap** - Add "CW" suffix to model #.
- Corner Bumpers (4)** - Add "B" suffix to model #.
- Solid Base** - Add "E" suffix to model #.
- Medical Caster Upgrade** - Add "MD" suffix to model #.
- Perimeter Bumper** - Add "PB" suffix to model #.
- Pan Stop** - Add "PS" suffix to model #.



New Age Industrial Corp., Inc. || [NewAgeIndustrial.com](http://NewAgeIndustrial.com) || Made in the USA

PO Box 520 • 16788 US Hwy 36 • Norton, Kansas 67654 || Phone: (800) 255-0104 • (785) 877-5121 || Fax: (877)-877-7687 • (785) 877-2616

This information is for general sales and engineering use only. New Age Industrial reserves the right to modify or make changes at any time, without notice, to materials and specifications.