

/// Frozen Drink Machine

6455-C

115V - Gravity Feed
Refrigerated Hopper Pre-Chills Mix

- ☆ Two Flavor // Countertop
- ☆ Up to 190, 10oz drinks per hour
- ☆ (2) 4 Qt Cylinder - (2) 8.5 Qt Hopper
- ★ Perfect solution for alcoholic and non-alcoholic frozen beverages in bars, restaurants, hospitals, schools and kiosks



Fast Freeze Down

Patented high efficiency heat exchanger allows fast freeze down with low energy consumption

Reduced Parts - Easy Cleaning

Reduced parts and single piece beater/shaft design improve cleaning time and operational experience.

Simple Control, Easy Operation

Simple and intuitive control system makes operation and viscosity adjustment easy, swift and more precise

Low Mix Indicator & Freeze Protection

Light turns "ON" at low mix to alert operator to add mix. Prevents Freeze Ups when mix is out.

Refrigerated Hoppers, Standby, and Indicator

Maintains product temperature in mix hopper overnight and improves freeze and recovery time. Indicator lights for standby/night mode.

Safety Protections & Light Box Merchandising

High pressure switch prevents compressor overheating. Thermal overload protects motor and drive train. Illuminated flavor cards to attract more business

Self-closing Dispensing Valve

Automatically prevents product overflow after dispense



★ The Spaceman Difference

QUALITY

Affordable Quality

Designed by Aerospace Engineers

- ✓ Craft quality design, less investment
- ✓ Built to last
- ✓ Luxurious mouthfeel

VALUE

Microcrystal Technology

3X Patented Freezing Speed

- ✓ Superior fast freeze
- ✓ Quick recovery
- ✓ Lowest energy cost per serving

SERVICE

Restriction-Free Service

Service on Your Terms

- ⊘ No binding contracts
- ⊘ No locked-in maintenance fees
- ⊘ No monthly equipment costs

/// Frozen Drink Machine

6455-C

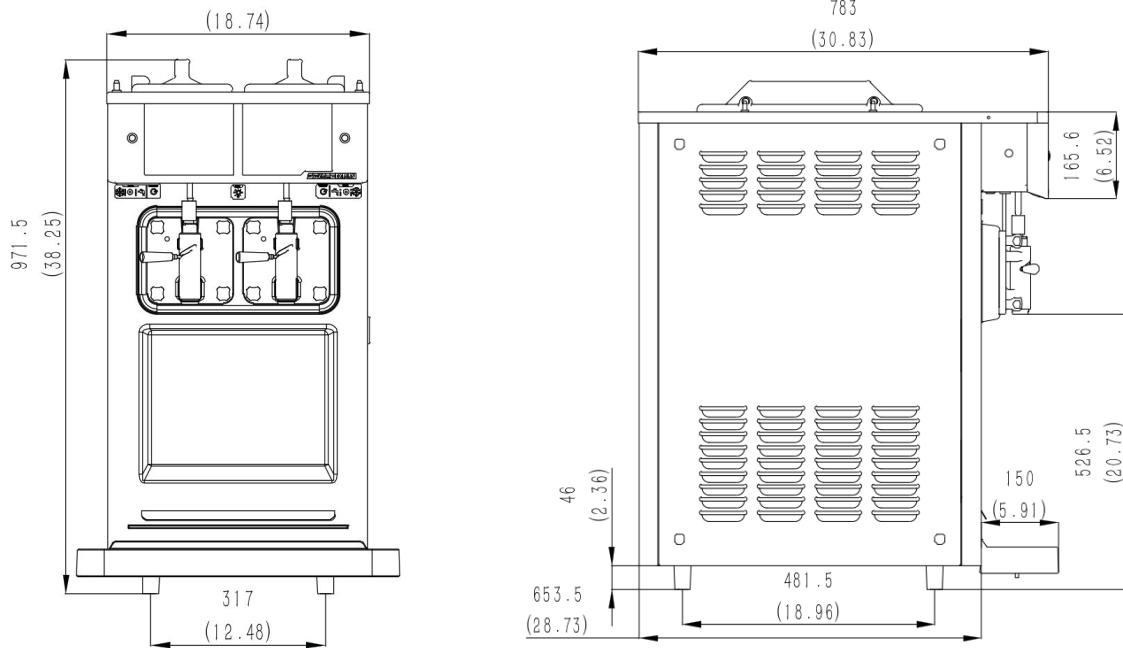

Specifications

Flavors	2
Freezing Cylinders	2 x 3.8L / 4.0qt
Mix Hoppers	2 x 8.0L / 8.5qt
Output Capacity (10oz)	190 serves/hr
Max Serving Size	16oz
Clearance Requirements	152mm/6"

Weight	Kg/lb
Net	146/ 325
Shipping	166/ 369
Volume	0.48 CBM / 17.10 CBF

Dimensions	Net (mm/in)	Shipping (mm/in)
Width	476/ 18.7	520/ 20.5
Depth	651/ 25.6	853/ 33.6
Height	950/ 37.4	1090/ 42.9

Electrical	FLA	Power(kW)	Plug
110-120/60/1	10	1.0	5-20P

Features

Control System	Single, Mechanical
Auto Closing Dispensing Valve	✓
Low Mix Indicator Light	✓
High Pressure Protection	✓
Thermal Overload Protection	✓
Refrigerated Hoppers	✓
Standby Mode	✓
Indicator Lights	✓
Low Mix Freeze Protection	✓

Available Options

Top Air Discharge Chute	✓
Water Cooled	✓

*Above specifications are subject to change without notice