

SPARTAN SERVING LINES

BY TITAN STAINLESS



502 USHER STREET • PAGELAND, SC • 704 243 8717 • WWW.TITAN STAINLESS.COM

SERVING COUNTER WITH CASHIER STATION

Titan's SPARTAN SERVING LINE counters are made using all-welded heavy gauge stainless steel construction. The front edges of the countertops feature our standard nosing: 1-1/2" flange down with 1/2" return at 45°. All other edges are turned down tight over the cabinet body. Tops are bolted to cabinet walls and reinforcement below.

Cabinet walls are faced with 2" wide mullions, and base shelves and mid-shelves are welded between cabinet walls and reinforced as necessary. (*Cashier counters feature a removable base shelf, underneath which is a cross-rail that can be used as a foot rest if desired.)

Cashier counters are provided with a cash drawer with money tray, GFCI receptacle in the cabinet base, and a grommeted hole in the top for the cord & plug on the POS station (supplied by others). The *double* cashier station (designated by the -D suffix in the model number) is supplied with two receptacles and two grommeted holes in the top.

The customer's (front) side is furnished with a folding, 11" wide, stainless steel tray slide with ridges for the ease of sliding trays across the serving line. The tray slide will sit 32" above the floor for elementary school applications, and 34"H for middle and high schools.

Each serving counter is furnished with a latch at the front (tray slide) and back for fastening to the next counter in the lineup. This allows counters to be joined together or removed with ease. The latch consists of a stainless steel rod which passes through small cutouts in the side of the counter, and is held in place with spring tension until unlatched.

All welds are ground and polished to a smooth finish. Cabinets are furnished with 5" diameter casters, with a 6" load height, and brakes at the employee (or *cashier's*) side. Each counter will be provided with a 10'-0" cord and plug(s) for immediate operation with no additional on-site wiring required.

OPTIONAL FEATURES AND ACCESSORIES:

- Laminated cabinet body
- Vinyl wraps / graphics
- Powder-coated cabinet body



*Single cashier station



*Single cashier side configuration RIGHT



*Double cashier station



TITAN STAINLESS

502 Usher Street • PO Box 8 • Pageland, SC 29728
Contact: 704-243-8717 • quotes@titan-stainless.com • www.titan-stainless.com



SPARTAN SERVING LINES BY TITAN STAINLESS



502 USHER STREET • PAGELAND, SC • 704 243 8717 • WWW.TITAN STAINLESS.COM

SERVING COUNTER WITH CASHIER STATION

**Cashier counter shown with base shelf removed and cross-rails exposed.*

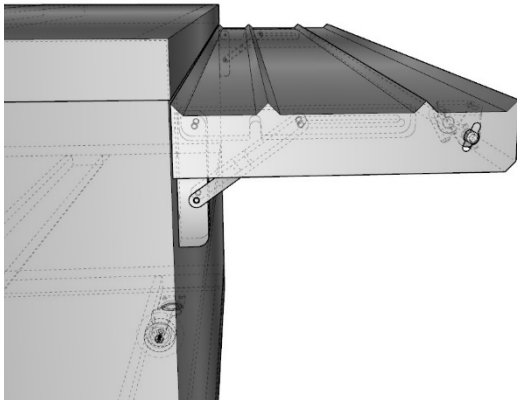

**All serving counters will include connection latches at front and back for joining counters together. Along with the other offerings in the SPARTAN serving lineup, this allows for the creation of complete serving lines with interlocking counters in whatever configuration is required for the application.*

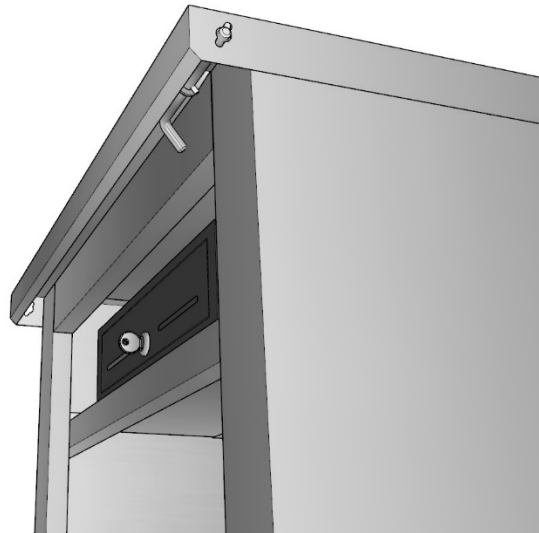

STANDARD MODEL NUMBERS AND INFO:

Model Number	Length	Depth (not including tray slide)	Height (to working surface)
SSL-30STC-32-CC-S	30"	32"	36"
SSL-30STC-32-CC-L	30"	32"	36"
SSL-30STC-32-CC-R	30"	32"	36"
SSL-4STC-32-CC-D	48"	32"	36"

- See **AutoQuotes™** for full list of model numbers and pricing
- Contact Titan Stainless for custom sizes and configurations – available upon request

