

Project: _____

Item: _____

Quantity: _____

Carrier Cart 95667



This multipurpose cart is designed for the storage and transport of food modules, boxes, pots and pans, wire baskets, and similar items

All shelves have three lips up with front lip down. The upper two shelves are slanted 1° toward the rear to facilitate drainage.

- Shelves are constructed of .080" sheet and reinforced with a 1½" x 1½" x .070" wall tubing framework.
- Base is constructed of 1½" x 2¾" x .070" wall tubing for extra strength.
- Equipped with four, 6" x 2" heavy duty plate type casters; two swivel, two swivel with brake.
- Lifetime Guarantee against rust and corrosion.
- Five-Year Guarantee against workmanship and material defects.

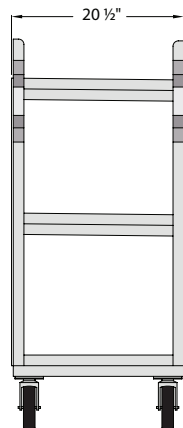
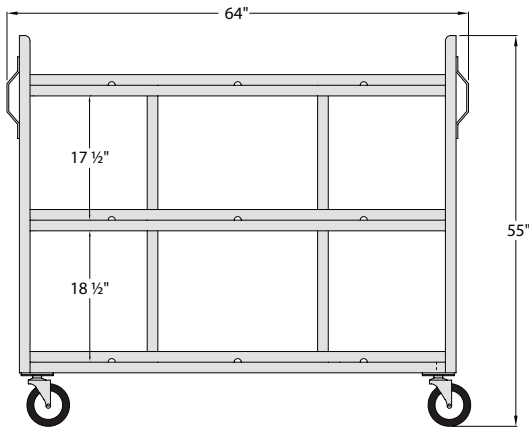

► Carrier Cart

Model No.	Size W-H-L	Shelf Size	Number Of Shelves	Shelf Spacing	Ship Lbs.
95667	20 ½" x 55" x 64"	20" x 60"	3	top = 17½" bottom = 18½"	175

Four 6" x 2" plate type casters; two swivel, two swivel with brake.



New Age Industrial Corp., Inc. || NewAgeIndustrial.com || Made in the USA 

PO Box 520 • 16788 US Hwy 36 • Norton, Kansas 67654 || Phone: (800) 255-0104 • (785) 877-5121 || Fax: (877)-877-7687 • (785) 877-2616

This information is for general sales and engineering use only. New Age Industrial reserves the right to modify or make changes at any time, without notice, to materials and specifications.