

DZC-C

Curved Glass Multi Deck Service



ADVANTAGES

- Create a bakery department destination
- Increase packout in a narrow footprint
- Exceptional styling
- Improved product visibility
- Energy efficiency



KEY POINTS

- Part of full bakery department solution
- Fully matching self-service case available
- Matching array of ambient displays



DELIGHT: A Full Bakery Department Solution with fully matching refrigerated and ambient displays



Create a Bakery Department Destination

Abundant décor and option solutions to match your store design and operational requirements

Exceptional Styling

Matching self-service case profile, low profile lift-up glass and flow through body panels ensure clean and smooth lines in your bakery department.



Improved Product Visibility

Large curved bent glass and full depth view ends ensure your bakery products look amazing



Energy Efficiency

Husmann modular coil design and EcoShine Ultra LED's ensures a lower cost of ownership



Wood Laminate Options

Black	White	Select Cherry	Columbian Walnut	Wild Cherry	Ginger Root Maple	Natural Pear	Fusion Maple	Formal Mahogany
Formica 909-58	Formica 949-58	Formica 7759-43	Wilsonart 7943K-07	Wilsonart 7054-60	Formica 7288-58	Wilsonart 7061-60	Wilsonart 7909-60	Pionite WY031



Husmann refrigerated merchandisers configured for sale for use in the United States meet or surpass the requirements of the DOE 2017 energy efficiency standards.

NOTE: These merchandisers are designed for use in stores when temperature and humidity do not exceed 76F and 55% R.H. We reserve the right to change or revise specifications and product design in connection with any feature of our products. Such changes do not entitle the buyer to corresponding changes, improvements, additions, or replacements for equipment previously sold or shipped.



ADDITIONAL PRODUCT INFORMATION

Scan or click on QR code:

- In-store photos
- Technical documents
- CAD files



LENGTHS:

DZC-C-R (Refrigerated): **4', 57", 75", 8'** and **12'**

DZC-C-D (Non Refrigerated): **4', 57", 75", 8'** and **12'**

FEATURES

- Laminated exterior finish solutions to match your bakery decor
- Clear glass top to improve product visibility and incase lighting
- Large clear glass rear service door to improve ergonomics and allow easy access to products
- Lift up front glass for easier stocking access and cleaning
- Air sweep minimizes sweating for improved product visibility
- Black interior (allows product to stand out)
- EcoShine ULTRA LED front canopy lighting with 5 year warranty
- Energy efficient fans

OPTIONS

- Painted or stainless steel exterior finish
- Various bumper styles
- Solid metal and glass shelving solutions
- Shelf PTM
- EcoShine ULTRA LEDs with 5 year warranty
- Shelves
- Ledge lights
- Rear canopy lighting
- 2-way mirrored glass rear service door
- End panels (solid or view)
- White or stainless steel interior

DELIGHT SOLUTIONS

- Self-service Merchandiser: [DZC-SS](#)
- Frozen Bakery: [SFNG](#)

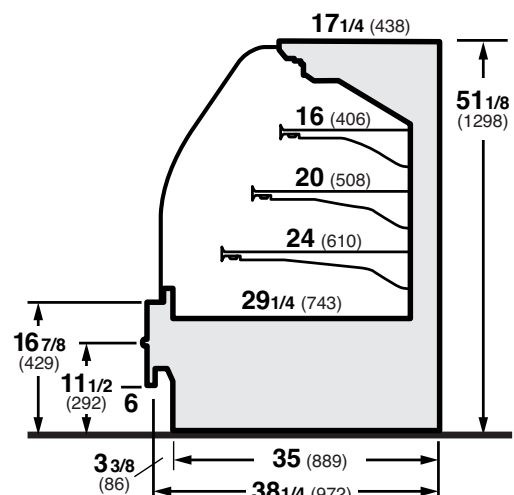

HUSSMANN®

Husmann Corporation
12999 St. Charles Rock Rd.
Bridgeton, MO 63044-2483
Ph: 800.592.2060

www.husmann.com