



# EVERPURE® CB20-124E WATER FILTER HOUSING

## HIGH FLOW BIG BOWL HOUSING

CGS-23 10" Parallel Filter Housing: EV9100-31



### APPLICATIONS

Foodservice

### FEATURES • BENEFITS

High pressure housing includes head, mounting bracket and bowl

Integral outlet pressure gauge monitors operation

Complete modular package lets you expand capacity as needed

### INSTALLATION TIPS

Choose a mounting location which is suitable to support the full weight of the system when operating (30 lbs. [13.6 kg]).

3/4" FNPT inlet and outlet connection.

Install on cold water lines only.

Do not install where unit is exposed to direct sunlight.

Allow a minimum of 4" (10.16 cm) clearance under the filter to facilitate cartridge change.

Do not braze or solder fittings into head.

Never use a saddle valve for connection.

### OPERATION TIPS

Change cartridges on a regular six (6) month preventative maintenance program.

Change cartridges when the difference between the inlet pressure and the system outlet gauge is greater than or equal to 20 psi (1.4 bar).

Service flow rate must not exceed 5.0 gpm (19 Lpm).

Always flush the filter cartridge to drain for fifteen minutes at time of installation and cartridge change.

### SIZING

Service Flow Rate: Maximum 5 gpm (19 Lpm)

# EVERPURE® CB20-124E WATER FILTER

## EV9100-31

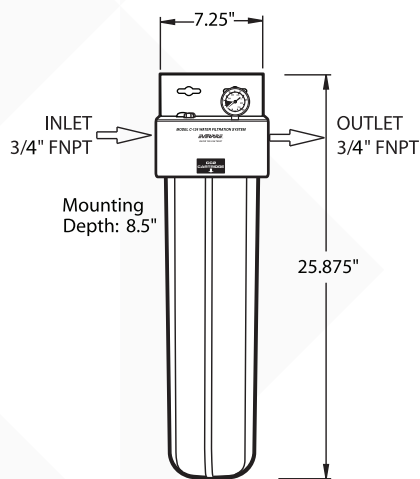

The contaminants or other substances removed or reduced by this drinking water system are not necessarily in your water. Do not use with water that is microbiologically unsafe or of unknown quality without adequate disinfection before or after the system.

### SPECIFICATIONS

#### Service Flow Rate

Maximum 5 gpm (19 Lpm)

#### Pressure Requirements

25 - 100 psi (1.4 - 6.9 bar), non-shock

#### Overall Dimensions

25.875" H x 7.25" W x 8.55" D  
(65.7 cm x 18.4 cm x 21.6 cm)

#### Inlet Connection

3/4" FNPT

#### Outlet Connection

3/4" FNPT

#### Temperature

35 - 100°F (2 - 38°C)

#### Electrical Connection

None required

#### Shipping Weight:

12 lbs. (5.4 kgs)

### WARRANTY

Everpure water treatment systems by Pentair® (excluding replaceable elements) are covered by a limited warranty against defects in material and workmanship for a period of five years after date of purchase. Everpure replaceable elements (filter cartridges and water treatment cartridges) are covered by a limited warranty against defects in material and workmanship for a period of one year after date of purchase. See printed warranty for details. Pentair will provide a copy of the warranty upon request.



#### WATER QUALITY SYSTEMS

EVERPURE-SHURFLO WORLD HEADQUARTERS, 1040 MUIRFIELD DRIVE, HANOVER PARK, IL 60133 USA • FOODSERVICE.PENTAIR.COM  
800.942.1153 MAIN (US ONLY) • 630.307.3000 MAIN • 630.307.3030 FAX • CSEVERPURE@PENTAIR.COM EMAIL

EVERPURE-SHURFLO AUSTRALIA, 1-21 MONASH DRIVE, DANDENONG SOUTH, VIC 3175, AUSTRALIA  
011.1300.576.190 TEL • 011.61.39.562.7237 FAX • AU.EVERPURE@PENTAIR.COM EMAIL

EVERPURE-SHURFLO CHINA, 21F CLOUD 9 PLAZA, NO 1118, SHANGHAI, 200052, CHINA  
86.21.3211.4588 TEL • 86.21.3211.4580 FAX • CHINA.WATER@PENTAIR.COM EMAIL

EVERPURE-SHURFLO INDIA, GREEN BOULEVARD, B-9/A, 7TH FLOOR - TOWER B SECTOR 62, NOIDA - 201301  
91.120.419.9444 TEL • 91.120.419.9400 FAX • INDIACUSTOMER@PENTAIR.COM EMAIL

EVERPURE-SHURFLO EUROPE, PENTAIR WATER BELGIUM BVBA, INDUSTRIEPARK WOLFSTEE, TOEKOMSTLAAN, 30 B-2200 HERENTALS, BELGIUM  
+32.(0).14.283.500 TEL • +32.(0).14.283.505 FAX • SALES@EVERPURE-EUROPE.COM EMAIL

EVERPURE-SHURFLO JAPAN INC., HASHIMOTO MN BLDG. 7F, 3-25-1 HASHIMOTO, MIDORI-KU, SAGAMIHARA-SHI KANAGAWA 252-0143, JAPAN  
81.(0)42.775.3011 TEL • 81.(0)42.775.3015 FAX • INFO@EVERPURE.CO.JP EMAIL

EVERPURE-SHURFLO SOUTHEAST ASIA, SOUTHEAST ASIA, 390 HAVELOCK ROAD, #04-01, KING'S CENTRE, SINGAPORE 169662  
65.6768.5800 TEL • 65.6737.5149 FAX • CSEVERPURE@PENTAIR.COM EMAIL

All Pentair trademarks and logos are owned by Pentair, Inc. or its affiliates. All other registered and unregistered trademarks and logos are the property of their respective owners. Because we are continuously improving our products and services, Pentair reserves the right to change specifications without prior notice. Pentair is an equal opportunity employer.