

TITAN STAINLESS CUSTOM FOODSERVICE FABRICATION

502 Usher Street · Pageland, SC · 704-243-8717 · www.titan-stainless.com



MAPLE TOP WORKTABLE WITH SPLASHES AND UNDERSHELF

TITAN STAINLESS Maple Top worktables are made using 1-3/4" thick maple and all-welded heavy gauge stainless steel construction. Assembly is not required; however, equipment can be disassembled for convenience. These worktables are provided with a solid slab of maple, with reinforcing channels to support the top. 4" tall x 1" thick risers are provided at the rear and both sides. 1-5/8" diameter tubing is fitted into stainless steel leg sockets, which are welded to reinforcement below, preventing surface imperfections. Legs are removable, and furnished with adjustable stainless steel bullet feet. Full-length stainless steel undershelf is welded to the table legs. All welds are ground and polished to a smooth finish.



MODEL NUMBER SELECTION / INFORMATION (Example #: 5MT-30-SLUBES)

Maple top worktables are available in standard lengths from 4'-0" to 8'-0", in 1-foot increments. Standard widths (front-to-back) are available in 24", 30", and 36". Units over 6'-0" long will be furnished with an additional set of legs.

- See **AutoQuotes™** for full list of model numbers and pricing, along with all additional accessories
- Custom sizes and configurations are available upon request

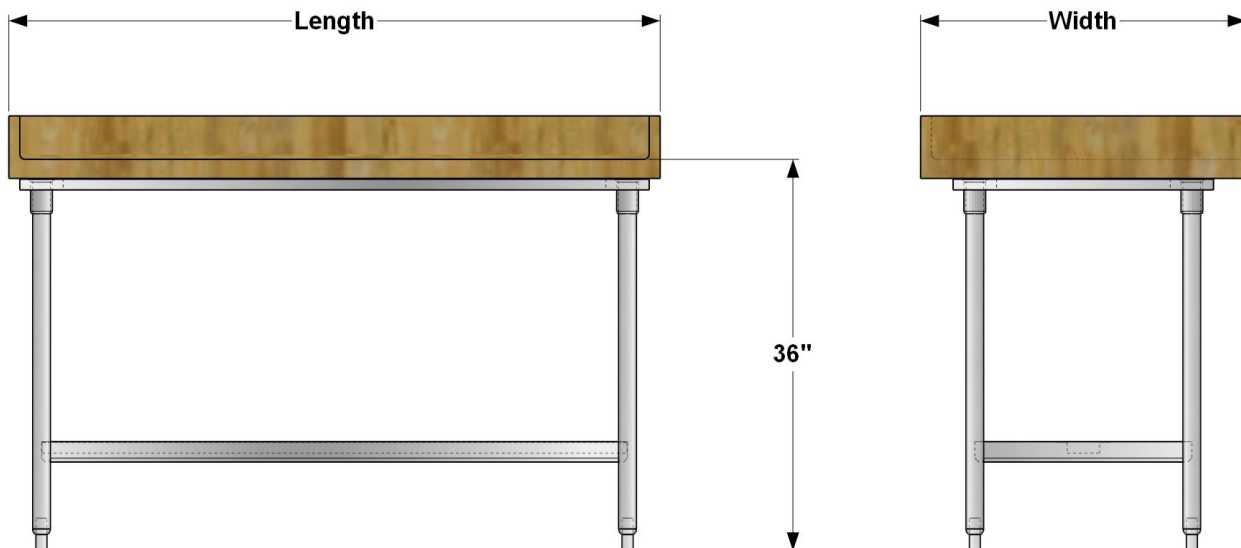

TITAN STAINLESS
502 Usher Street · PO Box 8 · Pageland, SC 29728
Contact: 704-243-8717 · quotes@titan-stainless.com · www.titan-stainless.com

