

"EBOS4" ENCLOSED BASE WORK TABLES

14GA Stainless Steel Top w/5" Riser - Open Front

FEATURES:

- 14GA Stainless Steel Flat Top
- Open Base Style
- Type 300 Stainless Steel With #4 Polish, Satin Finish
- Top Is Sound Deadened
- Reinforced With 1"x2" Channel Running Entire Length Of Table
- 1-1/2" Stallion Edge On Front And Rear With Side Edges 90 Degree Bend Down For Table Line-Up
- Stainless Steel Base And Undershelf
- Undershelf Is Secured In A Fixed Position, 10" Above Floor
- Shipped Standard Welded Set-Up

SPECIFICATIONS:

- Top: Stainless Steel Tops Are TIG Welded, Exposed Welds Are Polished To Match Adjacent Surface
- Top: 14GA Stainless Steel Type 300 Stainless Steel With #4 Polish, Satin Finish
- Shelf: 18GA Type 300 Stainless Steel, #4 Polish With Satin Finish
- Legs: 1-1/2" Square O.D., 16GA Tubular Stainless Steel
- Panels: 20GA Type 300 Stainless Steel, #4 Polish With Satin Finish
- Feet: 1" Adjustable Stainless Steel Bullet Feet



EBOS4-3072

CERTIFICATIONS:



ACCESSORIES

MODEL	DESCRIPTION
EBRS	Welded Intermediate Shelf - All Sizes

"EBOS4" ENCLOSED BASE WORK TABLES

LENGTH	# OF LEGS	24" WIDTH	WEIGHT (LBS)	30" WIDTH	WEIGHT (LBS)
36"	4	EBOS4-2436	115	EBOS4-3036	155
48"	4	EBOS4-2448	155	EBOS4-3048	172
60"	4	EBOS4-2460	180	EBOS4-3060	199
72"	4	EBOS4-2472	203	EBOS4-3072	226
84"	6	EBOS4-2484	232	EBOS4-3084	245
96"	6	EBOS4-2496	261	EBOS4-3096	280
108"	6	EBOS4-24108	286	EBOS4-30108	311
120"	6	EBOS4-24120	310	EBOS4-30120	342
132"	6	EBOS4-24132	334	EBOS4-30132	373
144"	6	EBOS4-24144	358	EBOS4-30144	404

ALL DIMENSIONS ARE TYPICAL. TOLERANCE +/- .500". JOHN BOOS & CO. RESERVES THE RIGHT TO CHANGE SPECIFICATIONS WITHOUT NOTICE.

DETAILED SPECIFICATIONS

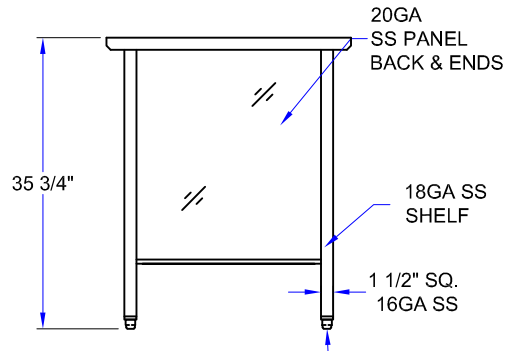
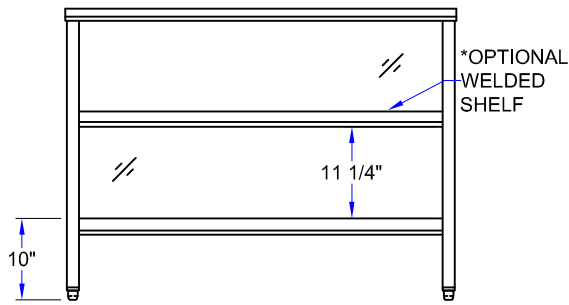
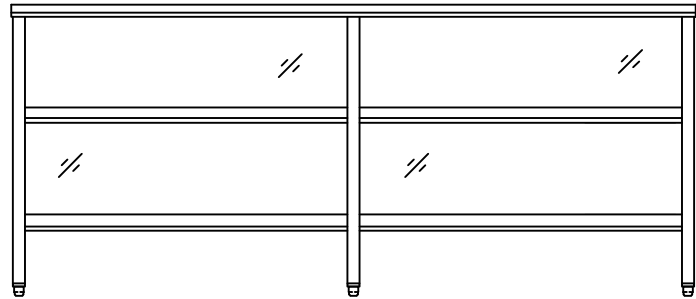
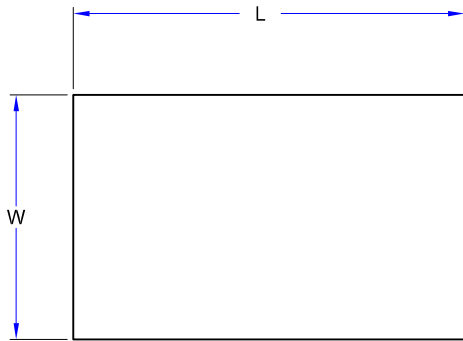

MODEL # STRUCTURE

S = Stainless Steel
O = Open Front
EB = Enclosed Base

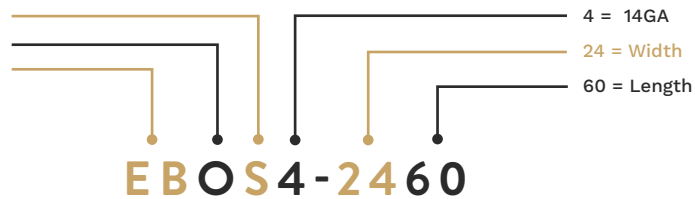

"EBOS4" ENCLOSED BASE WORK TABLES

LENGTH	# OF LEGS	24" WIDTH	WEIGHT (LBS)	30" WIDTH	WEIGHT (LBS)
36"	4	EBOS4-2436	115	EBOS4-3036	155
48"	4	EBOS4-2448	155	EBOS4-3048	172
60"	4	EBOS4-2460	180	EBOS4-3060	199
72"	4	EBOS4-2472	203	EBOS4-3072	226
84"	6	EBOS4-2484	232	EBOS4-3084	245
96"	6	EBOS4-2496	261	EBOS4-3096	280
108"	6	EBOS4-24108	286	EBOS4-30108	311
120"	6	EBOS4-24120	310	EBOS4-30120	342
132"	6	EBOS4-24132	334	EBOS4-30132	373
144"	6	EBOS4-24144	358	EBOS4-30144	404

ALL DIMENSIONS ARE TYPICAL. TOLERANCE +/- .500". JOHN BOOS & CO. RESERVES THE RIGHT TO CHANGE SPECIFICATIONS WITHOUT NOTICE.