

# Medium Water Boost Systems

Maintains consistent water pressure for fountain systems

# SHURflo®

## APPLICATIONS

Fountain

Coffee

Drinking Water

## FEATURES & BENEFITS

Increases flow and pressure to carbonated and non-carbonated soda valves for consistent drink quality

Maximizes filter life on filtration systems

Replaceable bladder for maximum system life and simple maintenance

Self priming pump can run without damage

Eliminates pulsation at dispenser valve resulting in more accurate brix ratio and maximum syrup utilization

Low profile allows for undercounter installation

Rigid stainless steel tanks

Complete turn-key package

Quick connects

NSF Certified



Medium Water Boost: 804-023  
Replacement Bladder: 94-697-00



## SPECIFICATIONS

<b>Booster Pump:</b>	SHURflo 90 psi 115 VAC 8000 series corded pump (NSF, UL, CUL listed)
<b>Accumulator Tank:</b>	2 gallon SS and butyl rubber bladder. (NSF listed)
<b>Water Ports:</b>	3/8" barb inlet/outlet
<b>Pre-charge:</b>	w/air at installation. 50 psi recommended for most beverage applications
<b>Draw down volume:</b>	0.75 gallon (@50 psi pre-charge)
<b>Dimensions:</b>	13" x 13" x 10"
<b>Electrical:</b>	115 VAC
<b>Weight:</b>	13 pounds (empty)
<b>Max Working Pressure:</b>	117 PSI
<b>Temperature Limits:</b>	34°-120°F (1.1° - 49°C)

# Medium Water Boost System

## 804-023

### INSTALLATION TIPS

Must be installed BEFORE the water filtration

Tank charge at time of installation is at 50 PSI

Check tank precharge each service visit to ensure optimum performance

Do not charge accumulator tank with CO2

Use NSF listed high pressure braided 3/8" ID tubing for inlet/outlet port (not included)

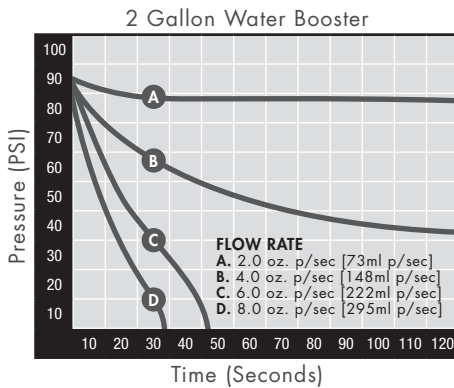

SHURflo reserves the right to update specifications, change prices, or make substitutions without notice.

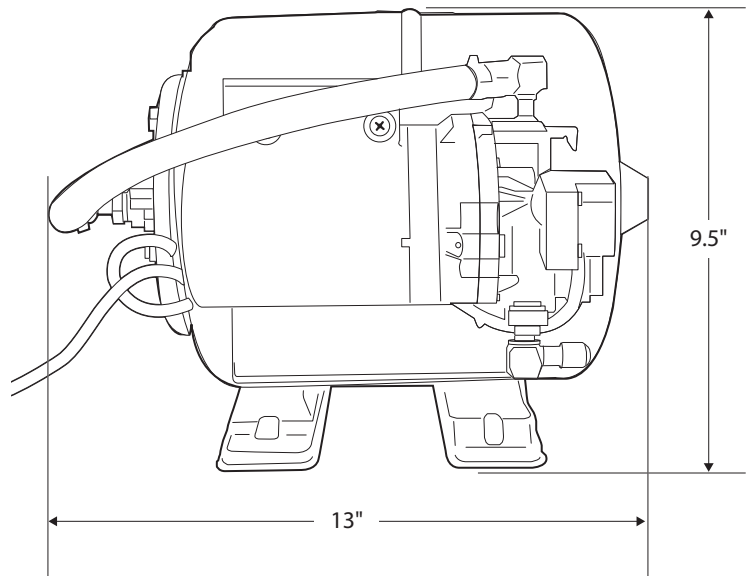
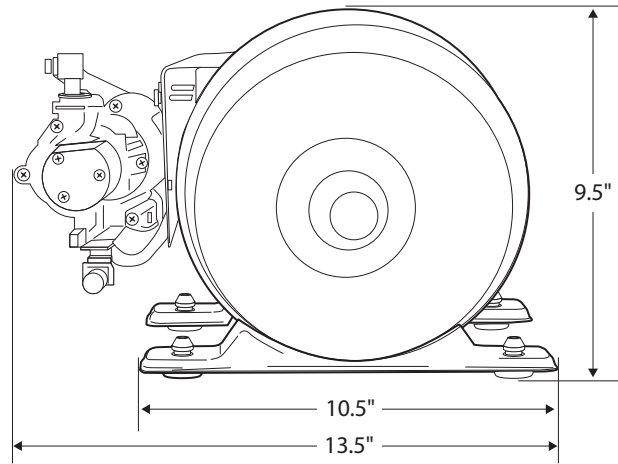

804-023

JA10

Everpure-Shurflo India  
A-25  
Mohan Co-operative Industrial Estate  
Mathura Road  
New Dehli, 110 044  
INDIA  
TEL: 011.661.188.00  
FAX: 011.661.188.22

Everpure-Shurflo Japan LLC  
Hashimoto MN Bldg. 7F  
3-25-1 Hashimoto Sagamihara-Shi  
Kanagawa 229-1103  
JAPAN  
TEL: 81.(0)42.775.3011  
FAX: 81.(0)42.775.3015

Everpure-Shurflo China  
21F Cloud 9 Plaza, No 1118,  
West Yan'an Road, Changning District  
Shanghai, 200052  
CHINA  
TEL: 86.21.3211.4588  
FAX: 86.21.3211.4580

**SHURflo®**  
*First in Fluid Innovation*  
Visit our website at [www.shurflo.com](http://www.shurflo.com)

Pentair Filtration Solutions, LLC  
World Headquarters-Everpure/Shurflo  
North and South America Sales  
1040 Muirfield Dr.  
Hanover Park, Illinois 60133  
USA  
TEL: 800.323.7873 (US only)  
TEL: 630.307.3000  
FAX: 630.307.3030

Everpure-Shurflo Australia  
2 Redwood Drive  
Notting Hill  
Victoria, 3168  
AUSTRALIA  
TEL: 011.61.39.574.4000  
FAX: 011.61.39.562.7237

Everpure-Shurflo Southeast Asia  
18 Boon Lay Way  
#04-110/111  
TradeHub 21, 609966  
SINGAPORE  
TEL: 65.6795.2213  
FAX: 65.6795.2219

Everpure-Shurflo Europe bvba  
Industriepark Wolfstee  
Toekomstlaan 30  
B-2200 Herentals  
BELGIUM  
TEL: +32.(0).14.283.500  
FAX: +32.(0).14.283.505