

Ultratherm™ Electric Rethermalizer

REO-1620

The Ultratherm™ Electric model REO-1620 is a rethermalizer designed to deliver maximum performance, value, safety and convenience.

Each Ultrafryer® rethermalizer model provides a unique combination of features such as a lever action handle for the drain and cook & hold or cook & remove controllers. These features are designed to heat and hold previously frozen foods.

STANDARD FEATURES

- Thaws, heats, and holds frozen food packets (chubs)
- Can accommodate twelve product bags at once
- Optional twelve-button timer
- Lever-action handle for drain
- Twin chrome-plated wire baskets with dividers
- Open-based construction
- Hinged access door
- All stainless steel construction
- Automatic water fill
- Automatic low-water heat shut-off



Project _____

Item _____

Quality _____

Approval _____

Date _____



Ultrafryer®

Ultratherm™ Electric Rethermalizer

REO-1620

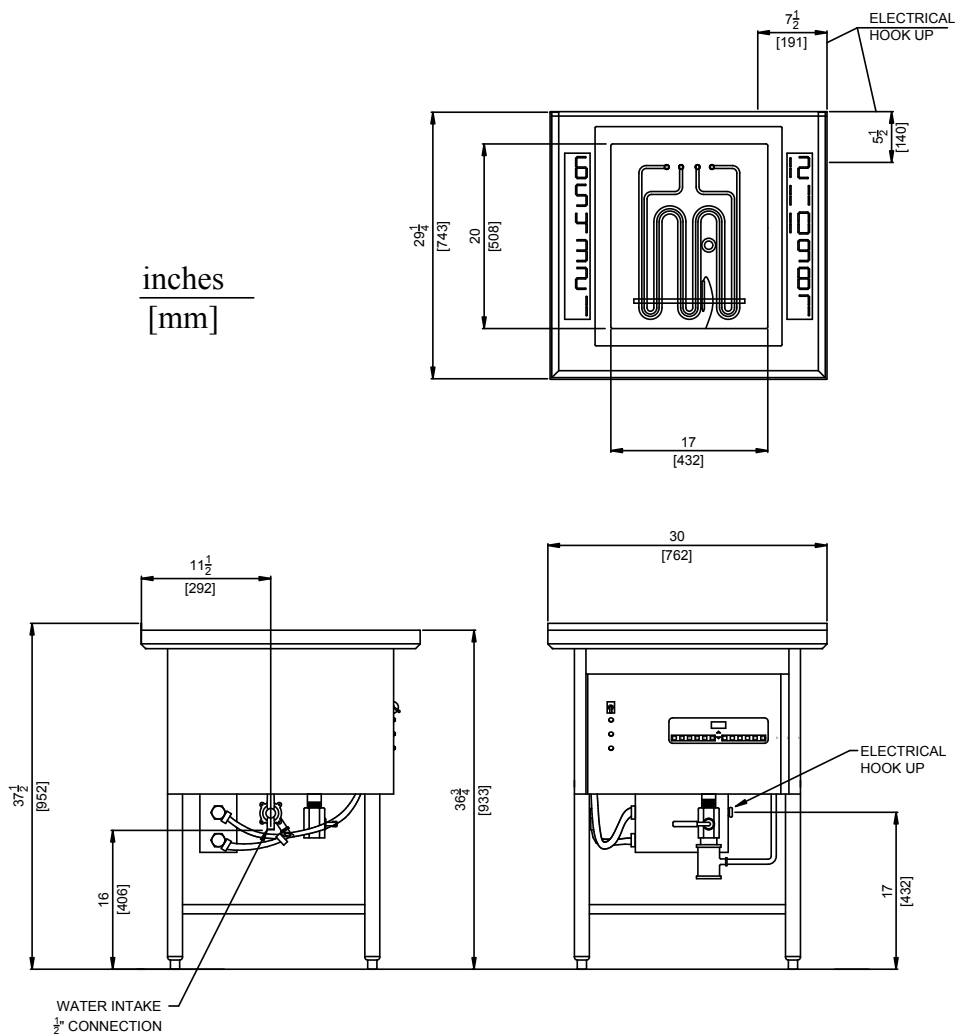

Sales ID#	Overall Size (H x D x W)	Baskets	Shipping Info	Electrical Requirements
REO-1620 Rethermalizer	37-1/2" x 29" x 30" (952.5 x 736.6 x 762 mm)	12" x 7-3/4" x 18" (305 x 196.9 x 457 mm) 10 separator plates standard	F.O.B. Factory San Antonio, Texas	Power cord not included 208 V, 60 Hz, 1 ph, 9.8 KW, 47.6 Amps 240 V, 60 Hz, 1 ph, 9.8 KW, 41.2 Amps 230 V, 50 Hz, 1 ph, 9.8 KW, 42.6 Amps

© 2017 Ultrafryer Systems, Inc. Due to continuing engineering development and improvements, specifications are subject to change without notice.

Revision date: 1.30.2019

Ultrafryer®