

## "HNB" WOOD TOP WORK TABLES

*w/ Galvanized Base & Bracing - 1 3/4" Thick Top*

### FEATURES:

- 1-3/4" Thick Northern Hard Rock Maple Top
- Top Is Finished With Penetrating Oil With Optional Natural Clear Varnique Finish (Varnique Finish Voids NSF)
- Galvanized Base & Adjustable Bracing
- Adjustable Bullet Feet
- Shipped Knocked-Down, Easy-To-Assemble

### SPECIFICATIONS:

- Top: Northern Hard Rock Maple
- Legs: 16GA Galvanized Steel
- Bracing: 18GA Galvanized Steel (6' Tables Come With 16GA Galvanized Steel)
- Gussets: Galvanized Steel
- Feet: 1" Adjustable Galvanized Steel

### CERTIFICATIONS:



### ACCESSORIES

#### DESCRIPTION

Drawer

Drawer Lock

Casters

Overshelves

Pot Rack

### "HNB" WOOD TOP WORK TABLES

LENGTH	24" WIDE	WT (LBS)	30" WIDE	WT (LBS)	36" WIDE	WT (LBS)
36"	HNB01	62	HNB07	74	HNB13	86
48"	HNB02	78	HNB08	94	HNB14	110
60"	HNB03	94	HNB09	114	HNB15	134
72"	HNB04	110	HNB10	134	HNB16	157
84"	HNB04A	134	HNB10A	162	HNB16A	198
96"	HNB05	150	HNB11	182	HNB17	212
108"	HNB05A	165	HNB11A	201	HNB17A	236
120"	HNB06	182	HNB12	222	HNB18	260

ALL DIMENSIONS ARE TYPICAL. TOLERANCE +/- .500". JOHN BOOS & CO. RESERVES THE RIGHT TO CHANGE SPECIFICATIONS WITHOUT NOTICE.

# DETAILED SPECIFICATIONS

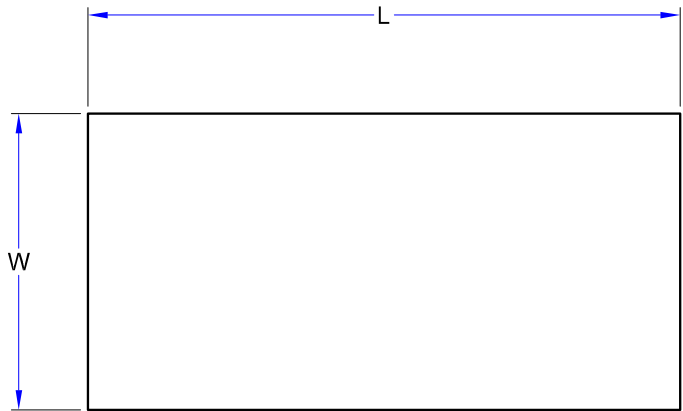

Units 7 Ft. & Larger Are  
Furnished With Six Legs  
Shelf Length = Length Minus 4.875"  
Shelf Width = Width Minus 4.25"

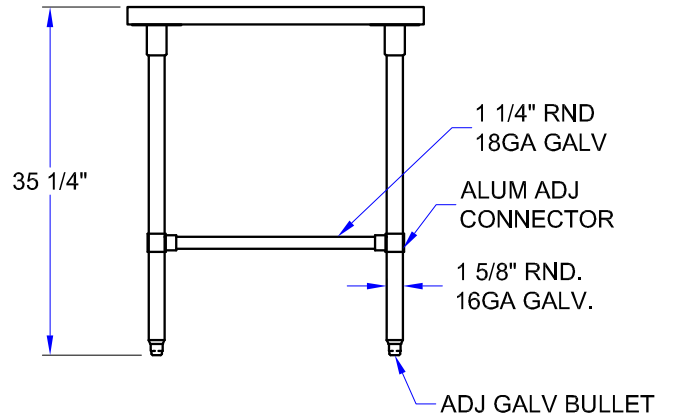
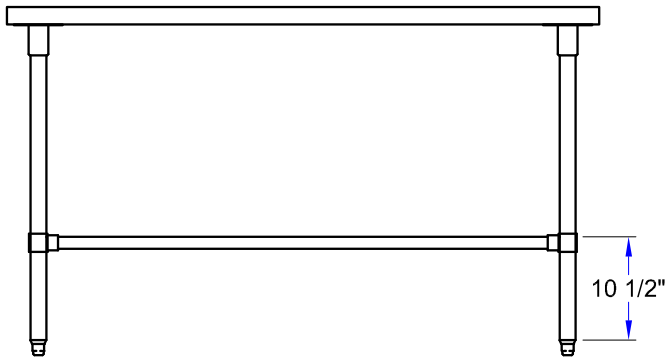

## "HNB" WOOD TOP WORK TABLES

LENGTH	24" WIDE	WT (LBS)	30" WIDE	WT (LBS)	36" WIDE	WT (LBS)
36"	HNB01	62	HNB07	74	HNB13	86
48"	HNB02	78	HNB08	94	HNB14	110
60"	HNB03	94	HNB09	114	HNB15	134
72"	HNB04	110	HNB10	134	HNB16	157
84"	HNB04A	134	HNB10A	162	HNB16A	198
96"	HNB05	150	HNB11	182	HNB17	212
108"	HNB05A	165	HNB11A	201	HNB17A	236
120"	HNB06	182	HNB12	222	HNB18	260

ALL DIMENSIONS ARE TYPICAL. TOLERANCE +/- .500". JOHN BOOS & CO. RESERVES THE RIGHT TO CHANGE SPECIFICATIONS WITHOUT NOTICE.