

Item # _____
 Qty # _____
 Model # _____
 Project # _____



DUKERS

Quality Commercial Refrigeration



CONVECTION OVEN

(Double Layer)DCCOG2+DCCOG

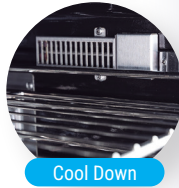
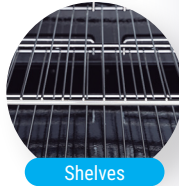

PRODUCT DESCRIPTION

- Elegant stainless steel exterior for easy cleaning.
- Durable double-pane glass with independent doors.
- Electronic spark ignition with an automatic pilot system with safety shut off.
- Oven temperature range between 175°F to 500°F
- Two speed-fan with adjustable cool down mode.
- Includes Ten adjustable shelves.
- Double-stacking options to optimize your kitchen space



HIGH QUALITY STAINLESS STEEL & ROBUST DESIGN

GAS RANGE MODEL	DIMENSION		
	Width	Depth	Height
DCCOG2+DCCOG	38 in	39 3/4 in	68 1/2 in



Los Angeles | San Francisco | Dallas
 Houston | Florida | Chicago | New Jersey

1-800-931-8628

@ info@dukersusa.com

www.DukersUSA.com

DETAILS & SPECIFICATIONS

DCCOG2+DCCOG

Front View

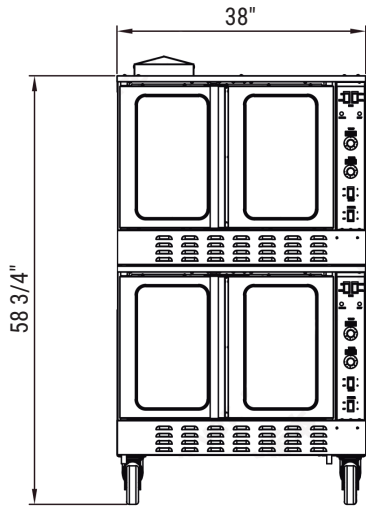

DCCOG2+DCCOG

GAS SOURCE	LGP/NG
POWER (W)	887 x 2
BURNER	3 x 2 count
SINGLE BURNER	18000 BTU/H
TOTAL OUTPUT	54000 x 2 BTU/H
GAS PRESSURE	NG: 4 "WC LGP: 10 "WC
NOZZLE	55/45
CONTAINER FITMENT	18

Top View

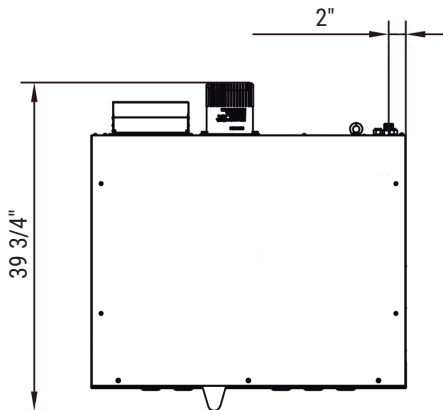

Side View

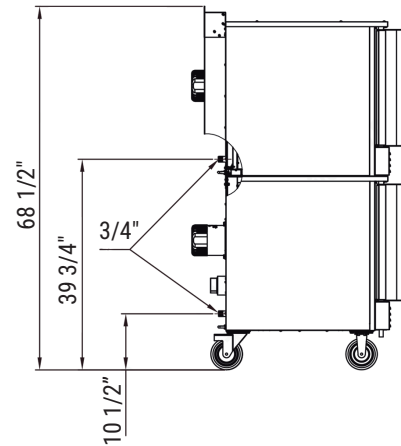

Model	Packaging Dimensions (inches)			Net Weight (lbs)	Ship Weight (lbs)
	W	D	H		
DCCOG2+DCCOG	41 7/10"	45 3/5"	75 1/2"	365	540



Los Angeles | San Francisco | Dallas
Houston | Florida | Chicago | New Jersey

1-800-931-8628

@ info@dukersusa.com

www.DukersUSA.com