

Dutchess

Bakers' Machinery Company, Inc.

A subsidiary of Superior-Lidgerwood-Mundy Corp

Item No.

Model DUT/AV-02

20 Quart Table Top Mixer



Standard Features:

- ◆ Heavy Duty 1/2 HP Motor, 115/60/1, 10.98 Amp
- ◆ # 12 Attachment Hub
- ◆ Gear Driven Transmission
- ◆ 3-Speed with 15-Minute Timer w/Auto Shut-off
- ◆ Safety Bowl Guard
- ◆ Bowl Lift Safety
- ◆ Manual Bowl Lift
- ◆ Dough Hook
- ◆ Wire Whip
- ◆ Beater Paddle
- ◆ Stainless Steel Bowl
- ◆ Bowl Locking Handles
- ◆ 7-Foot Power Cord
- ◆ 3-yr Limited Parts Warranty
- ◆ 1-Year Full Parts & Labor Warranty



Dutchess Bakers' Machinery Company

302 Grand Avenue, PO Box 39

Superior, WI 54880-0039

Toll Free: 800-777-4498

Phone: 715-394-4444

Fax: 715-394-2406 |

E-mail: sales@dutchessbakers.com

Web: www.dutchessbakers.com

ISO 9001-2008 Compliant

Model DUT/AV-02 Table Top Planetary Mixer

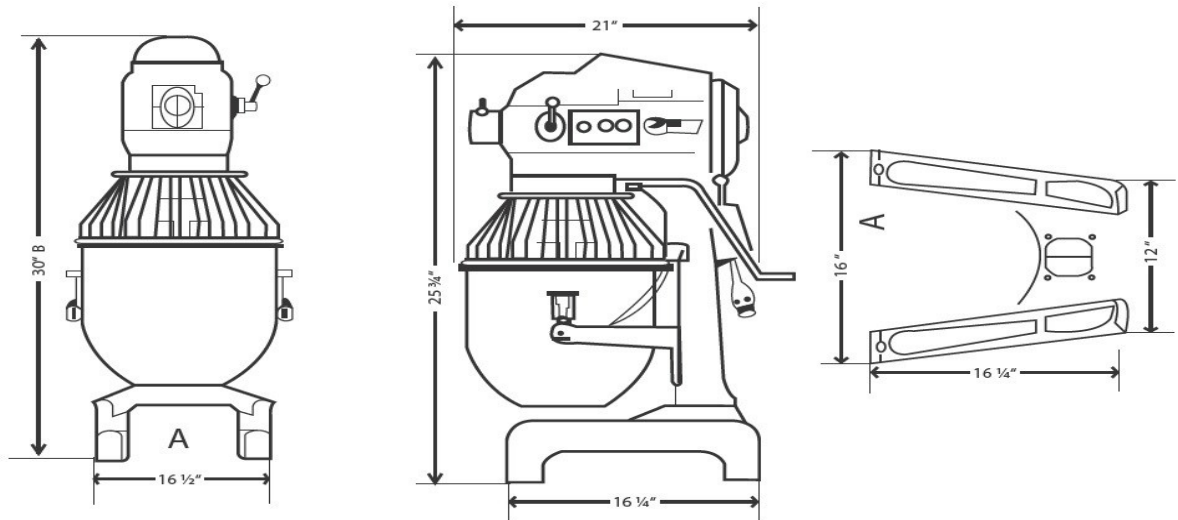

Electrical:

1/2 hp Heavy Duty Motor 115 volt / 60 hz / 1-phase, 10.98-Amp (220v, 1 or 3-phase available)

7" Power Cord with Standard NEMA Plug

Dimensions:

16.5" Wide x 30" High x 21" Depth

Weight:

216 lbs. Net Weight, 256 lbs Shipping Weight.

Speed	Agitator RPM's	Attachment Hub RPM's
1	76	125
2	142	248
3	259	453

Warranty:

- ◆ 3-Year Limited Parts (Motor, Transmission and Drive Train.
- ◆ 1-Full Year Parts and Labor

DUTCHESS BAKERS' MACHINERY COMPANY, INC. 302 GRAND AVENUE, SUPERIOR, WI 54880-0039

TOLL FREE: 800-777-4498 - PH: 715-394-4444 - FAX: 715-394-2406