



# SPEC SHEET

## KoolMore 36 in. Commercial Chef Base Refrigerator Storage Cabinet

SKU: KM-BR-362D

### FEATURES

- Chef-Based Refrigerator Cabinet
- Digital Temperature Control
- Stainless-Steel Finish
- Automatic Defrost
- Temperature Range: 33-40°F
- ETL Listed for Safety and Sanitation



### CLOSE UP IMAGES



\* *Pans not included*

# TECHNICAL SPECS

## Dimensions

Depth	36.4
Width	32.1
Height	25.9
Interior Depth	22.5
Interior Width	24.6
Interior Height	15.7
Shelf Width	NA
Shelf Depth	NA
Depth Including Handles	32.1
Depth Excluding Handles	32.1
Depth Less Door	32.1
Depth With Door Open 90 Degrees	53.6
Power Cord Length	98.5

## Capacity

Weight	173.8
Gross Cubic Feet	6.5
Net Capacity Cu. Ft.	5.7
Individual Drawer Capacity	88 lbs.
Top Capacity	792

## Features & Material

Door Style	Drawer
Number Of Drawers	2
Defrost Type	Automatic
Refrigerant Type	R290
Temperature Control Type	Digital
Ambient Temperature Range	90 F
Temperature Range	33-40 F
Casters	4
Top Material	SUS304
Top style	Marine Edge
Top Thickness	1.8 in
Interior Material	SS 201
Exterior Material	SS 430

## Electric Data & Certifications

Amps	4
Phase	1
Plug Type	NEMA 5-15P
Voltage	115
Hertz	60
Wattage	287
Horsepower	0.3536
Certifications	ETL Listed for Safety and Sanitation

# Plan View

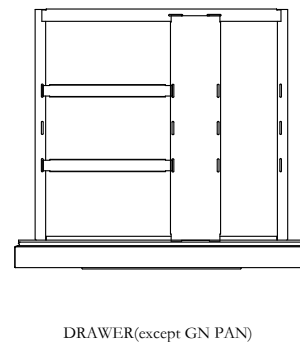
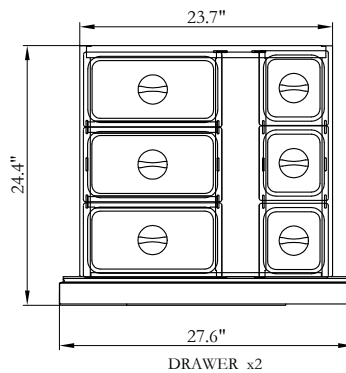
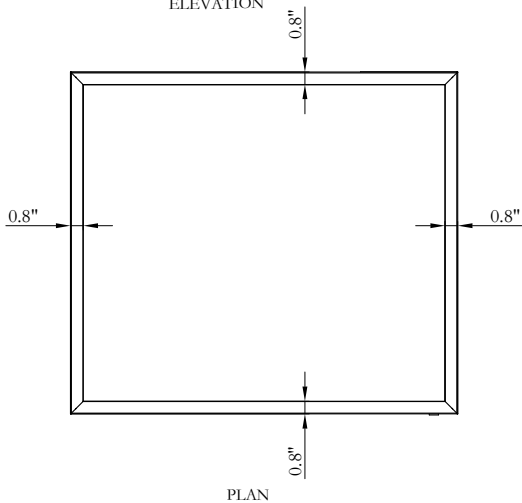
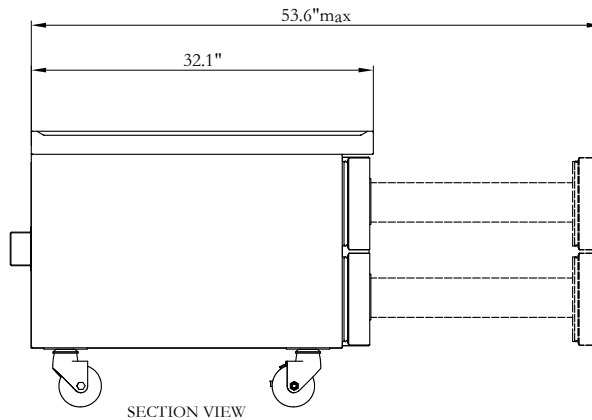
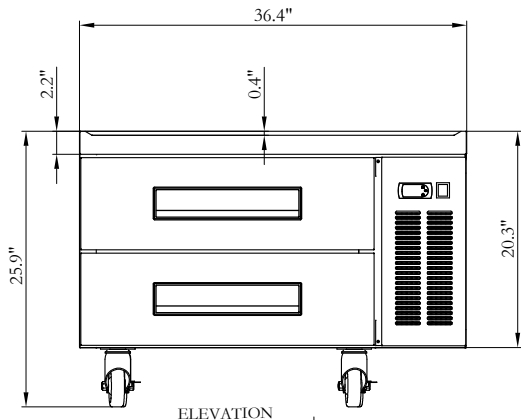

## CERTIFICATIONS



706 Eastern Parkway STE 1G, Brooklyn NY 11213  
 718-576-6342  
 info@koolmore.com