



# STAINLESS STEEL SQUARE LEG FILLER TABLE



**ALL-WELDED  
SET UP**

Item #: \_\_\_\_\_ Qty #: \_\_\_\_\_  
 Model #: \_\_\_\_\_  
 Project #: \_\_\_\_\_

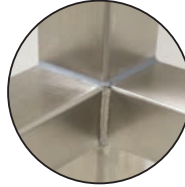

Welded Square  
Cross Bracing



Stainless Steel  
Adjustable  
Bullet Feet

**FEATURES:**

- TOP is furnished with 1-1/2" Square edge on all four sides.
- 1 1/2" Stainless Steel Square Tube Legs.
- 1 1/2" Stainless Steel Cross Tube Bracing.
- Stainless Steel Adjustable Bullet Feet.

**MATERIAL:**

- TOP: 16 gauge stainless steel type "300" series.
- LEGS: 1 1/2" Square Tubular Stainless Steel.

**CONSTRUCTION:**

- All TIG welded. Exposed weld areas polished to match adjacent surfaces.
- Entire unit mechanically polished to a satin finish.
- Welded Legs & Cross Bracing.
- Legs welded to upper top.
- Ships set up.

Model #	Width	Length	Wt.	Cu. Ft.
TFT-3016-X	16"	30"	35 lbs.	15

## DETAILS and SPECIFICATIONS

TOL ± .500"

ALL DIMENSIONS ARE TYPICAL

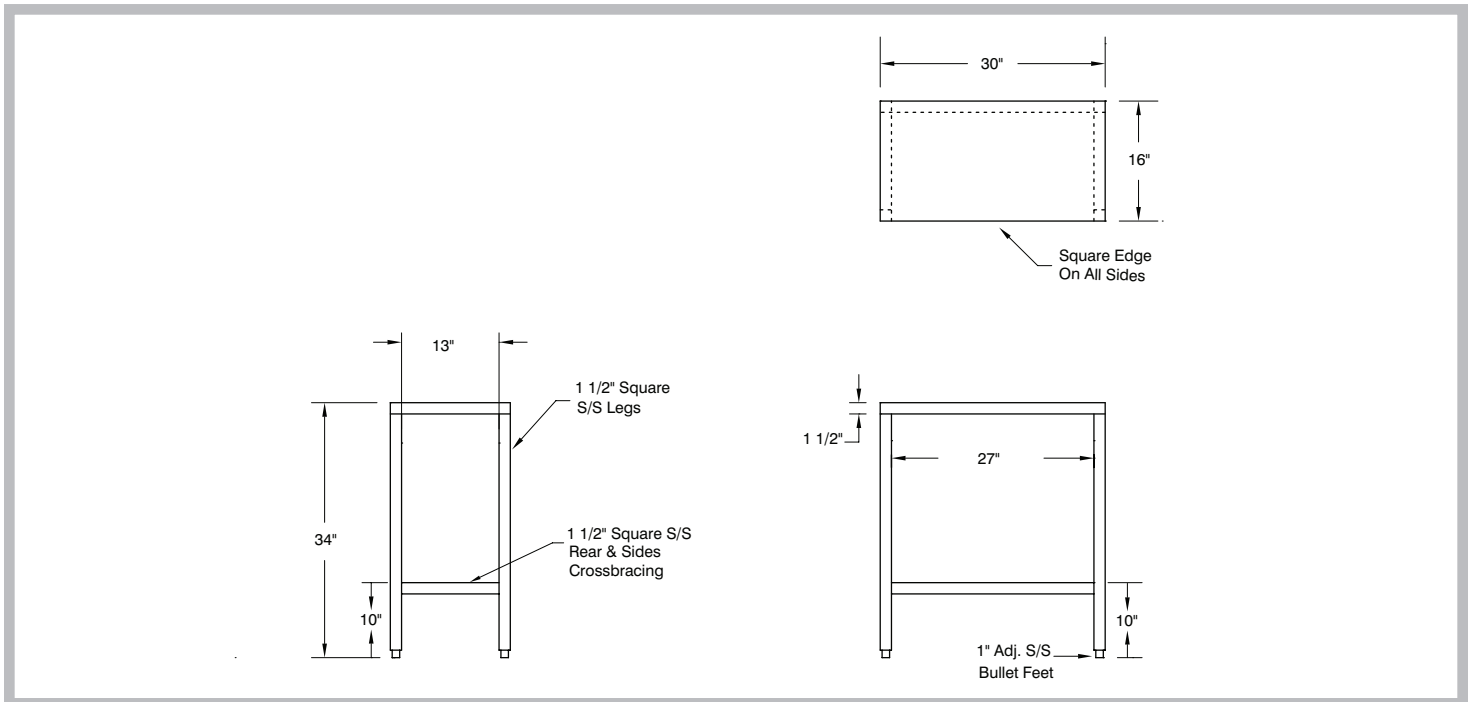

Customer Service Available To Assist You 1-800-645-3166 8:30 am - 7:00 pm E.S.T.

For Orders & Customer Service:  
 Email: customer@advancetabco.com or Fax: 631-242-6900

For Smart Fabrication™ Quotes:  
 Email: smartfab@advancetabco.com or Fax: 631-586-2933