



# ATLAS METAL

1135 N.W. 159th DRIVE, MIAMI, FLORIDA 33169

TEL 305.625.2451

TOLL FREE 800.762.7565

FAX 305.623.0475

WWW.ATLASFOODSERV.COM

SALES@ATLASFOODSERV.COM

Project: \_\_\_\_\_

Item No.: \_\_\_\_\_

Quantity: \_\_\_\_\_

## DROP-IN SERVING EQUIPMENT



WSB-15

## WATER STATION

Non-Mechanical,  
with Ice Chest

WSB-15

WSB-19

### SPECIFICATIONS

**TOP:** Constructed of 18 gauge, type 304 stainless steel, die stamped with a raised perimeter bead. There shall be a solid vinyl gasket under the beaded edge to form a seal to the counter top, thus preventing seepage or marring of the counter top. A covered pan insert is secured to the top, and is equipped with a 1/4" IPS drain and a removable anti-splash grate. Mounted above the drain pan is a chrome plated, brass glass filler with a volume regulator and stream director.

**ICE CHEST:** The inner liner shall be 22 gauge, type 304 stainless steel. All corners are covered with a minimum 1/4" radius. A 1" plastic drain fitting is provided.

**INSULATION:** The pan is fully insulated with high density polystyrene, 1" thick on all sides, 1-1/2" thick on the bottom and enclosed with a 24 gauge galvanized steel outer liner.

**LID:** The ice chest is provided with a S/S double pan, insulated lid with a rubber, self-insulating hinge. The entire lid is removable.

*Specifications subject to change without notice.*

### STANDARD FEATURES

- Chrome plated, lever action glass filler
- Large capacity ice chest - fully insulated to hold ice longer
- Removable S/S hinged lid
- Factory applied gasket - makes installation a snap and seals units to the counter top, thus eliminating seepage
- Sanitary - provided with a drain trough with anti-splash grate
- 1-Year Parts & Labor Warranty
- NSF Certified

### ACCESSORIES

- 3020-2 - Pitcher Filler
- LLD - Lid Locking Device "Non-certified part"

\*Please see Operation & Installation Manual for ALL operation and maintenance details.

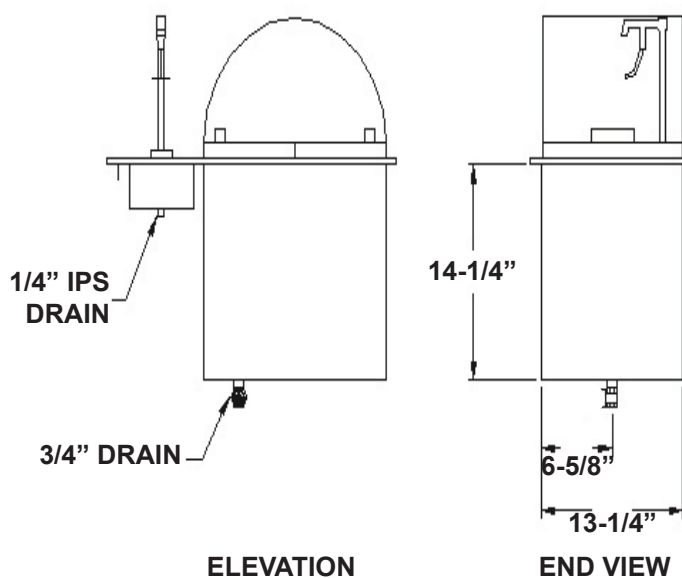
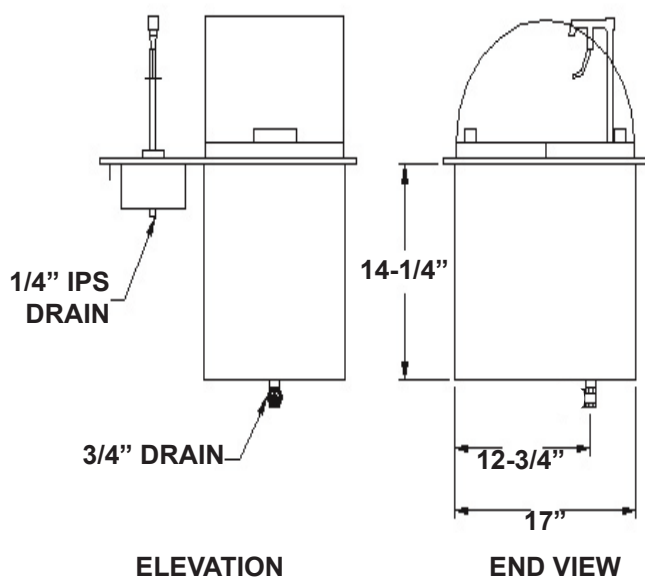
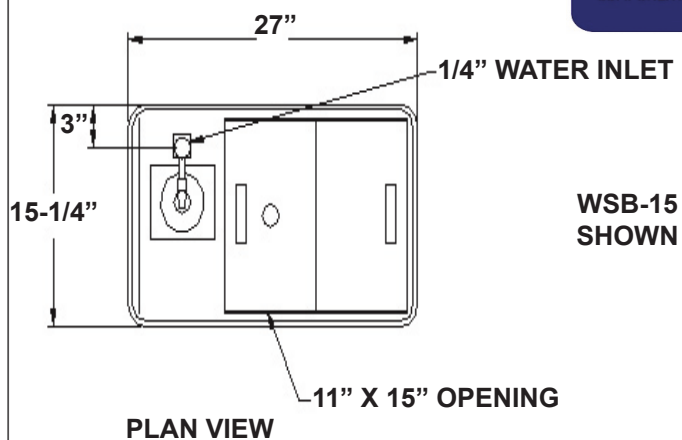
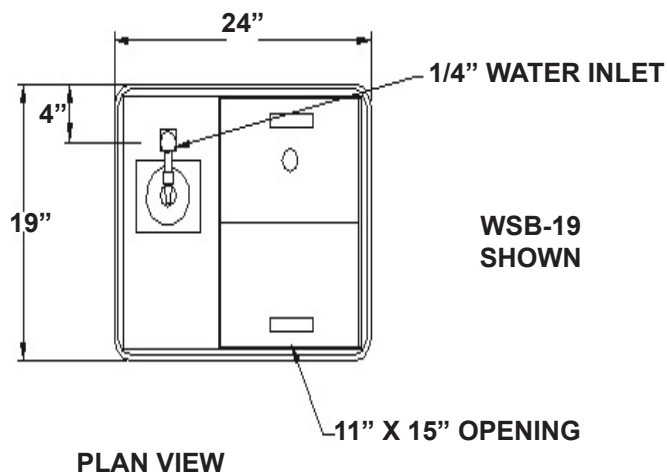

MODEL	CUT-OUT REQUIRED	ICE CAPACITY (LBS.)	SHIP WT (LBS.)
WSB-15	13-1/2" X 25-1/4" (34.2 X 64.1cm)	40 (18.1kg)	78 (35.4kg)
WSB-19	17-1/4" X 22-1/4" (43.8 X 56.5cm)	60 (27.2kg)	78 (35.4kg)