



# Flat Top Work Tables

14 Ga. Stainless Steel Work Tables



Use your smart phone to scan the above QR code to visit our website:  
www.bk-resources.com

## Certifications:



## Features:

- Three (3) Sound Deadened Integrally Welded 5" "C" Channels to Reinforce and Maintain Level Working Surface
- 1 5/8" Diameter Stainless Steel Legs
- 1 Year Warranty

## Options:

- Single & Double Overshelves
- Drawer Assemblies
- Casters
- Upgraded Feet
- Extra Shelves
- Adjustable Table Mount Pot Rack



## Material:

### QTT Series: S/S w/ Galvanized Legs & Undershelf

- T-304 14 ga. Stainless Steel Top
- Galvanized Legs & Adjustable Undershelf
- Adjustable High Impact Corrosion Resistant Feet

### QVT Series: S/S w/ Stainless Steel Legs & Undershelf

- T-304 14 ga. Stainless Steel Top
- Stainless Steel Legs & Adjustable Undershelf
- Adjustable Stainless Steel Feet

### QTT Series S/S w/ Galv. Legs & Undershelf

Part #	Length	Width	Product Weight (lbs)
QTT-3636	36"	36"	-
QTT-4836	48"	36"	-
QTT-6036	60"	36"	-
QTT-7236	72"	36"	145.00
QTT-9636	96"	36"	-

### QVT Series S/S w/ S/S Legs & Undershelf

Part #	Length	Width	Product Weight (lbs)
QVT-3636	36"	36"	70.00
QVT-4836	48"	36"	105.00
QVT-6036	60"	36"	130.00
QVT-7236	72"	36"	145.00
QVT-9636	96"	36"	187.00

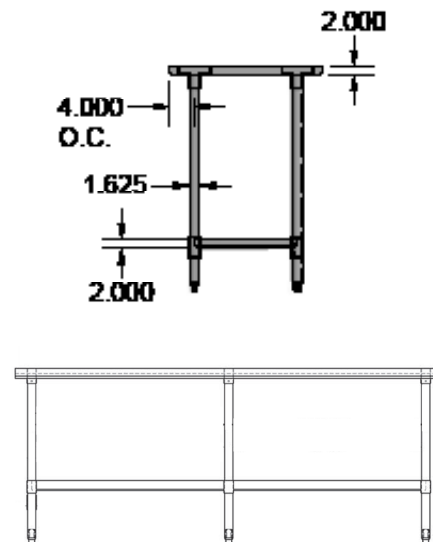
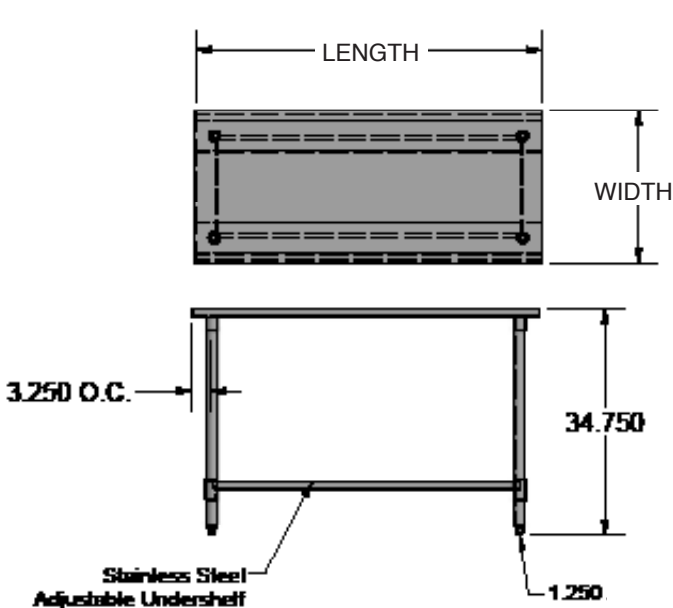

96" TABLES ARE FURNISHED WITH SIX (6) LEGS

PRODUCT DATA SHEET

BK RESOURCES

