

# SaniServ®

## MODEL 108C

  
MADE IN USA



**73**  
FROZEN  
COCKTAILS/HR

## GREAT FOR RESTAURANTS AND CONCESSIONAIRES

The SaniServ® model 108C Frozen Beverage Freezer provides owners and operators with a low cost alternative to SaniServ's regular 108. Get the same merchandising visibility in a small footprint. The 108C's extra large 8 inch face plate design provides great product visibility, along with moderate production and reliability.



Job: \_\_\_\_\_

Item No. \_\_\_\_\_



**DESIGNED FOR MEDIUM VOLUME APPLICATIONS**  
7 Gallons per Hour - 25 Quart Capacity

**Use SaniServ® Model 108C to Create**



**Dimensions:** Width (16.6") Depth (28.5")  
Height (37.1") Weight (210 lbs)

**Electrical Requirements:**  
115/60/1 = 15 Amps

**Serving Estimate:**  
Up to 73 Frozen Cocktails / hr



**About the 108C**

**Cooling Options**



We reserve the right to change specifications and product designs without notice. Such revisions do not entitle the buyer to corresponding changes, improvements, additions, or replacements for previously purchased equipment.



**✓ SPACE SAVING - Small Footprint Design**

SaniServ® model 108C offers frozen product visibility in reliable, space saving equipment and design! Owners and operators can turn the countertop into a highly colorful profit center by providing the frozen beverages customers enjoy!

**✓ EASY CLEANING AND OPERATION - Fewer Parts = Simplified Cleaning**

SaniServ® equipment is designed and built with the fewest parts to be disassembled, cleaned and sanitized than any other machine in the industry.

**✓ HIGH RETURN ON INVESTMENT - Increased Profits**

SaniServ® machines combine affordable efficiency with consistent product quality and fast, quiet operation to insure customer satisfaction with high profit frozen beverages.

**✓ QUALITY DESIGN - Durability**

SaniServ® machines are built to achieve long and dependable life through simplicity of design. Every machine is shipped standard with a stainless steel exterior, durable steel interior frame construction, heavy-duty components and consistency systems.

# MODEL 108C

## ECONOMY SERIES

Minimum Wall Clearance  
Both Sides and Back  
6 inches (152 mm)

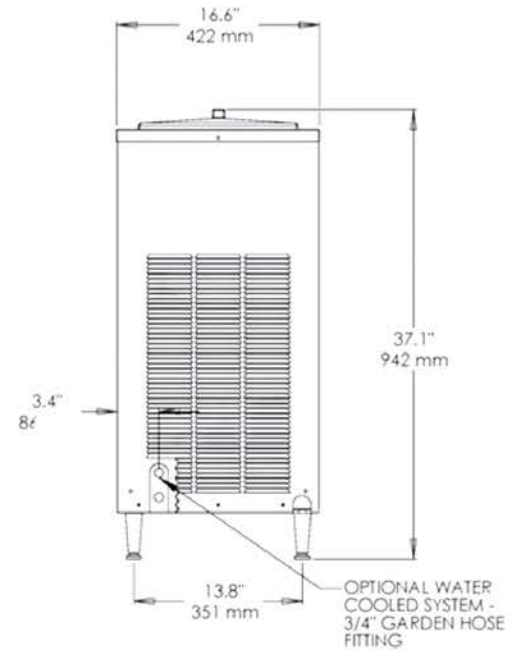
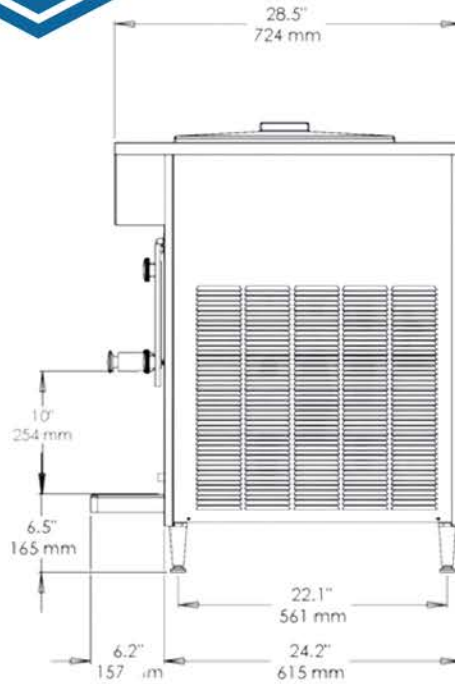
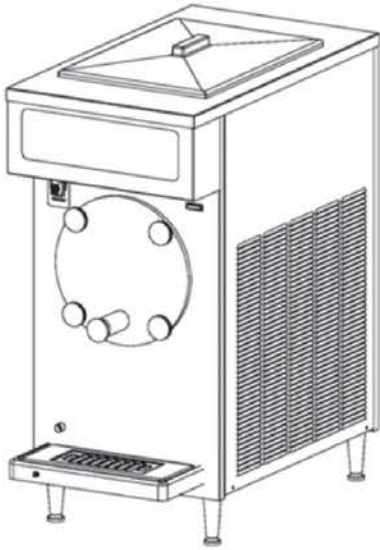

ELECTRICAL				WIDTH	HEIGHT	DEPTH	WEIGHT	VOLUME
VOLTS	Hz	Ph.	Amps	INCHES (MM)	INCHES (MM)	INCHES (MM)	LBS. (Kg)	CU FT. (cu. m.)
115	60	1	15	16.2 (422)	37.1 (942)	28.5 (724)	210 (95)	
Shipping Specifications				22.5 (572)	41 (1042)	34.5 (876)	285 (129)	18.5 (.53)

### SPECIFICATIONS

**Cooling System:**

Air

**Dasher and Compressor**

**Motors:**

1/2 HP Dasher

3/4 HP Compressor

**Refrigerator Type:**

R404A

**Listings:**

UL, cUL

### FEATURES

**Evaporator and Mix Reservoir**

**Capacity:**

25 Quarts (23.6 liters)

**Dasher:**

Heavy-Duty Stainless Steel with low friction scraper blades.

**Controls:**

Automatic consistency controls for improved product consistency.

### WARRANTY

Parts	90 days
Compressor	1 year
Evaporator	1 year
Labor	30 days

**Options:**

- Tune Up Kit
- Drink Spinner
- Counter Top Mounting Pad
- Machine Stand