

Expanding Stem Casters

1-5/8" Stem Work Table Caster with Polyolefin Wheel

Certifications:



Features:

- Fits Standard 1-5/8" Tubing by Expanding the Stem Creating a Secure Fit
- Double Ball Bearing Raceway for Long Wear and Added Strength
- With or Without Top Lock Brake
- Raceway Dust Cover

Material:

- Injection Molded Polyolefin
- Temperature Range -45° to 180°F
- Highly Resistant to Chemicals and Solvents
- Zinc Plated
- Polyolefin Wheel

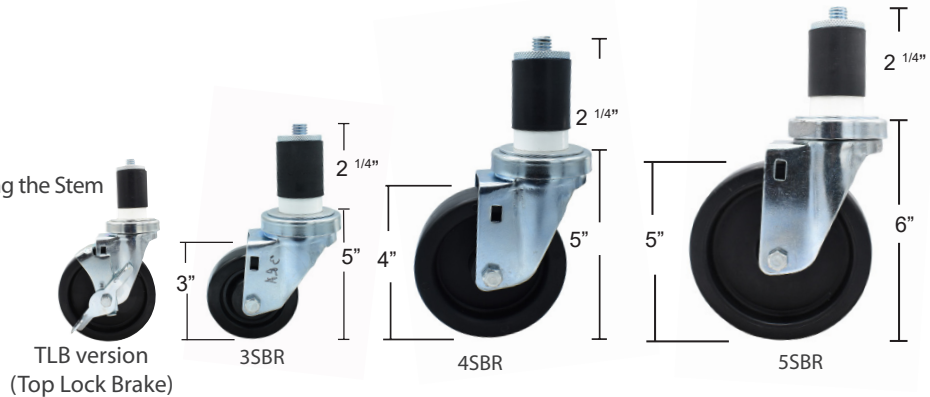

Part Number	Brake	Wheel Size	Capacity
3SBR-RA-LDP	-	3"	300 LBS
3SBR-RA-LDP-TLB	TLB	3"	300 LBS
4SBR-RA-LDP	-	4"	300 LBS
4SBR-RA-LDP-TLB	TLB	4"	300 LBS
5SBR-RA-LDP	-	5"	300 LBS
5SBR-RA-LDP-TLB	TLB	5"	300 LBS
5SBR-RA-LDP-PS4	TLB	(4)Pack 5" Polyolefin Wheel	300 LBS
5SBR-RA-LDP-PS6	TLB	(6)Pack 5" Polyolefin Wheel	300 LBS