

- **NE3627RSV** 35-3/4"L x 33"D x 27-7/8"H
- **NE4827RSV** 47-3/4"L x 33"D x 27-7/8"H
- **NE6027RSV** 59-3/4"L x 33"D x 27-7/8"H
- **NE7227RSV** 71-3/4"L x 33"D x 27-7/8"H

Included

- NOTE: Glass warranty only applicable to first point of delivery
- Breeze~E (Type-II) self-contained refrigeration
- (2) Levels of clear glass shelving removable and adjustable on 1" centers
- Condensate pan (self-contained refig. only)
- LED top & shelf lights
- NOTE: Overall case height is 47-1/4" (includes below counter)
- One piece formed ABS plastic tub
- One year parts & labor; 5 year compressor warranty
- Vertical, fixed front & side UV bonded frameless glass
- Warmest average product temperature of 40°F or less

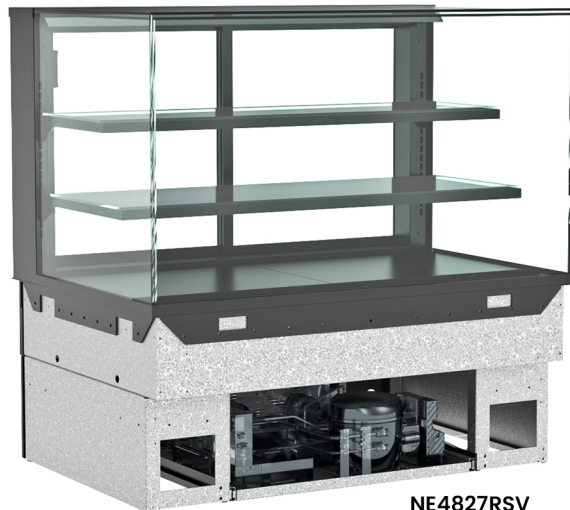

NE4827RSV

Specify	Standard Features	Additional Options
FRAME EXTERIOR COLOR	• Powder coated Silversan Black	• Powder coated (stock/non-stock colors) • Stainless steel
INTERIOR COLOR	• Powder coated Silversan Black	• NOTE: Interior color must be FDA & NSF approved • Powder coated (stock colors, specify RAL#) • Stainless steel
BASE	• Slide in counter assembly	
LEFT END GLASS	• Glass end	• No end glass w/ synchronized defrost
RIGHT END GLASS	• Glass end	• No end glass w/ synchronized defrost
REAR DOORS	• Clear glass rear sliding doors	• Reflective glass rear sliding doors
LIGHTS	• LED 3500K w/ frosted lens	• LED 3000K w/ frosted lens • LED 4000K w/ frosted lens
ELECTRICAL CONNECTION	• 10' Straight blade power cord (self-cont.)	• 10' Locking power cord (self-cont.) • Electrical leads (remote)
REAR VENTED PANEL	• None	• NOTE: Unit can intake & discharge from rear w/ optional rear vented panel • Powder coated (stock/non-stock colors) • Stainless steel
REFRIGERATION	• Breeze~E (Type-II) self-contained refrigeration (rear access)	• Breeze~E (Type-II) self-contained refrigeration (front access) (see important notes) • Remote w/thermostat, solenoid & TXV (rear access)
MISCELLANEOUS		• Rear door lock • Second year parts & labor warranty (excludes compressor)
ACCESSORIES		• Clean Sweep® coil cleaner (self-cont.)

Intended Environment: Type II - Designed to operate in ambient conditions of 80°F and 55% relative humidity unless noted otherwise in system information below.		
Zone	Intended Product To Be Displayed	Warmest Avg Prod Temp ° F
1	Unpackaged refrigerated products	40

PLAN VIEW

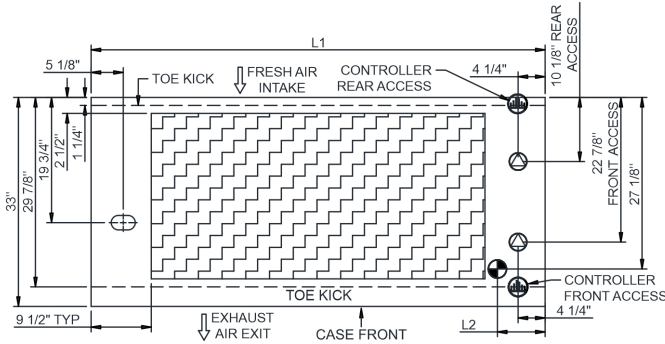

R290 SELF-CONTAINED ACCESS DIMENSIONS PROVIDED.
CONTACT FACTORY FOR ALL OTHER SELF-CONTAINED ACCESS DIMENSIONS

	"A"	"B"	"C"	"D"		"M"	"N"
NE3627RSV	8 1/2"	16"	8 1/2"	9 5/8"	NR3647RSV	15 3/8"	25 1/4"
NE4827RSV	8 1/2"	28"	8 1/2"	9 5/8"	NR4847RSV	21 3/8"	25 1/4"
NE6027RSV	8 1/2"	40"	8 1/2"	9 5/8"	NR6047RSV	27 3/8"	25 1/4"
NE7227RSV	8 1/2"	52"	8 1/2"	9 5/8"	NR7247RSV	33 3/8"	25 1/4"

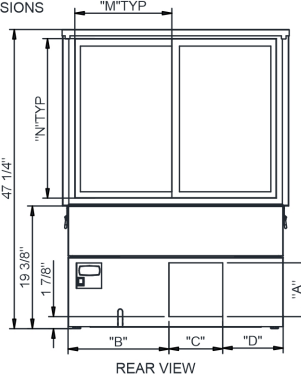

REAR VIEW

SIDE VIEW

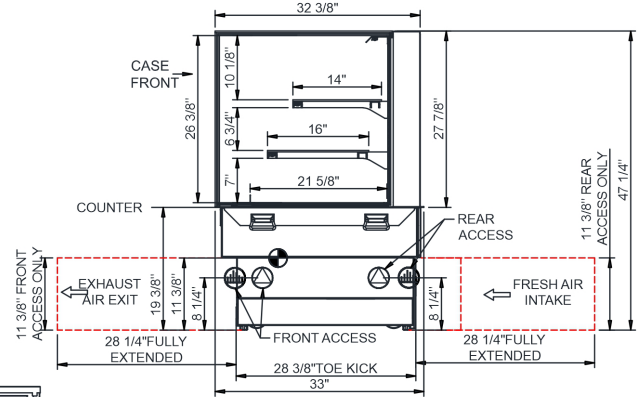

NOTES:

- 11 3/8" TALL, FULL WIDTH OF CASE OPENING IN CABINET OR COUNTER IS REQUIRED TO PULL OUT REFRIGERATION SYSTEM.
- SEE DESIGN GUIDE FOR CUTOUT SIZE IN CABINET FOR CASE TO DROP INTO.
- BACK OF COUNTER / CABINET MUST BE VENTED PROPERLY FOR ADEQUATE AIRFLOW TO CONDENSER.
- **REPRESENTS REAR PULLOUT REFRIGERATION. AIR FLOW INTAKE AND EXIT DETAILS ARE REVERSED WITH FRONT PULLOUT REFRIGERATION OPTION.
- SELF-CONTAINED ACCESS ONLY BY PULLING OUT CONDENSER UNIT.
- SEE "COUNTER INSTALLATION GUIDE" FOR AIR FLOW REQUIREMENTS.

NOTE: ALL DIMENSIONS APPROXIMATE

- ELECTRICAL JUNCTION BOX (SUPPLIED WITH 6" LEADS OR POWER CORD).
- LOCATION OF DRAIN TUBE FOR REMOTE REF. ONLY (SUPPLIED WITH 3/4" OR 1 1/2" PVC TUBE).

- REFRIGERATION LINE CONNECTION.
- REMOTE FLOOR SINK & UTILITIES ACCESS AREA.

- SELF-CONTAINED CASE SERVICE ACCESS AREA.
- DRY CASE SERVICE ACCESS AREA.

Model Technical Specifications																
Model	L"	L1"	L2"	System Circuit Volts			Phs	Freq	Amps ***	Watts	Wires	NEMA Plug	SST	Conv. Rack BTUH	Para. Rack BTUH	Est Wt
				Remote (DX)	Circuit #1	110-120										
NE3627RSV	N/A	35.75	7.50	Remote (DX)	Circuit #1	110-120	1	60	1.08	35	2+G	Leads Single	24.00	1015	940	750
				Self-Contained (R290)	Circuit #1	110-120	1	60	10.73	965	2+G	5-15P or L5-15P	N/A	N/A	N/A	
				Self-Contained (R513A)	Circuit #1	110-120	1	60	9.76	765	2+G	5-15P or L5-15P	N/A	N/A	N/A	
NE4827RSV	N/A	47.75	7.50	Remote (DX)	Circuit #1	110-120	1	60	1.08	41	2+G	Leads Single	24.00	1318	1220	850
				Self-Contained (R290)	Circuit #1	110-120	1	60	11.18	996	2+G	5-15P or L5-15P	N/A	N/A	N/A	
				Self-Contained (R513A)	Circuit #1	110-120	1	60	9.76	770	2+G	5-15P or L5-15P	N/A	N/A	N/A	
NE6027RSV	N/A	59.75	7.50	Remote (DX)	Circuit #1	110-120	1	60	1.38	59	2+G	Leads Single	20.00	1620	1500	950
				Self-Contained (R290)	Circuit #1	110-120	1	60	11.18	1,006	2+G	5-15P or L5-15P	N/A	N/A	N/A	
				Self-Contained (R513A)	Circuit #1	110-120	1	60	9.86	778	2+G	5-15P or L5-15P	N/A	N/A	N/A	
NE7227RSV	N/A	71.75	7.50	Remote (DX)	Circuit #1	110-120	1	60	1.38	64	2+G	Leads Single	20.00	1922	1780	1,050
				Self-Contained (R290)	Circuit #1	110-120	1	60	15.48	1,543	2+G	5-20P or L5-20P	N/A	N/A	N/A	
				Self-Contained (R513A)	Circuit #1	110-120	1	60	9.86	783	2+G	5-15P or L5-15P	N/A	N/A	N/A	

*** Does not include electric defrost on freezer models.

Regulatory Approvals:

All Models
 Accordance with AHRI Std 1200
 ETL Listed to UL 471
 ETL Listed to CAN/CSA 22.2 No. 120
 ETL Sanitation to NSF/ANSI 7



In Accordance with
AHRI Std 1200

DOE 2017
Energy Efficiency
Compliant



Important Notes:

- ELECTRICAL NOTE: If GFCI is required, a GFCI breaker MUST be used in lieu of a GFCI receptacle
- Back side of counter must be open or vented the full length of the unit to allow proper ventilation for the refrigeration system.
- A vent in the front of the counter recommended to help dissipate compressor heat.
- Rear Access Standard - Counter must be configured to allow air to be drawn in the rear and discharged out the front.
- Front Access Option - Counter must be configured to allow air to be drawn in the front and discharged out the rear.
- Unit can intake and discharge from rear with optional rear vented panel.
- 19.25" minimum space required beneath counter surface.
- Glass warranty only applicable to first point of delivery.

⚠ WARNING: This product can expose you to chemicals, including Urethane (Ethyl Carbamate), which are known to the State of California to cause cancer and birth defects or other reproductive harm. For more information go to www.P65Warnings.ca.gov.