



# EVERPURE® MRS-100CC-BL REVERSE OSMOSIS SYSTEM

CONFIGURABLE SYSTEM THAT DELIVERS REVERSE OSMOSIS OR BLENDED WATER FOR MULTIPLE FOODSERVICE APPLICATIONS



MRS-100CC-BL System:  
EV9973-63 (115 VAC/60 Hz)

Options and Replacements:

- 6TO-BW Cartridge: EV9607-41 (standard)
- MR-100 Cartridge: EV9627-11 (standard)
- 7CC-BW Cartridge: EV9627-05 (standard)
- 7TO-BW Cartridge: EV9627-04 (optional-greater capacity)
- Prefilter Kit: EV9795-81 (optional)
- P5 Cartridge: 155014-43 (optional-prefilter replacement)

## APPLICATIONS

- Combi Ovens
- Boilerless Conventional Steamers
- Flash Steam
- Cheese Melters
- Coffee
- Espresso
- Tea
- Ice

## FEATURES • BENEFITS

- Reduces corrosion and lime scale buildup that can cause excessive machine downtime, increased maintenance costs; plus scale reduction reduces energy costs
- Adjustable blend valve allows custom tailoring of the dissolved mineral content in the treated water. This valve controls the amount of influent water that is mixed with reverse osmosis (RO) water, creating a blend that gives the best steam equipment protection and performance
- This controlled re-mineralization is also desirable for coffee and other applications that require some hardness to achieve optimum results
- Sanitary cartridge replacement is simple, quick and clean – internal filter parts are never exposed to handling or contamination
- Wall mount design allows for flexible installation

## INSTALLATION TIPS

- Choose a mounting location capable of safely supporting the full weight of the components when in operation
- Delimiting of existing water using equipment is recommended
- Install vertically with cartridges hanging down and allow 3" (76 mm) on all four sides of unit for cover removal and service access
- The product water tubing/piping and associated fittings connecting the RO product outlet to the equipment being serviced should be suitable for use with high purity water
- Refer to Instruction & Operation Guide for cartridge flushing and RO start-up

## OPERATION TIPS

- Change filter cartridges on a regular 6-month preventative maintenance program
- Change RO cartridges on a regular 2-year preventative maintenance program
- Proper pretreatment is required to control RO Cartridge (membrane) scale formation and/or fouling
  - Raw water hardness in excess of 7 grains per gallon (120 ppm) should be softened
  - The raw water may contain particulates and the use of a prefilter is recommended
- Contact Pentair Everpure Technical Service for pretreatment recommendations

## SIZING

- Daily Production Rate - RO Processor Only: 100 gpd (378 Lpd)
- RO Processor With Blend: Capacity will vary based on tap water TDS, RO percent rejection and desired blend water TDS
- An example of the adjusted capacity is shown below:
  - Example: 500 ppm tap water, 90% rejection, 100 ppm blend setting
  - Result: 100 gpd (378 Lpd) RO Processor Only + 12.5 gpd (47.32 Lpd) filtered tap water = 112.5 gpd (425.85 Lpd) nominal
  - 0.078 gpm (0.295 Lpm) nominal

# EVERPURE® MRS-100CC-BL REVERSE OSMOSIS SYSTEM

## EV9973-63

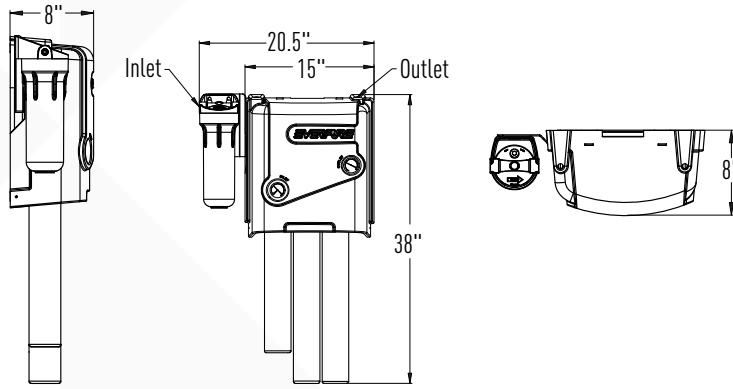

The contaminants or other substances removed or reduced by this drinking water system are not necessarily in your water. Do not use with water that is microbiologically unsafe or of unknown quality without adequate disinfection before or after the system.

### WARRANTY

Everpure water treatment systems by Pentair® (excluding replaceable elements) are covered by a limited warranty against defects in material and workmanship for a period of one year after date of purchase. Everpure replaceable elements (filter cartridges and water treatment cartridges) are covered by a limited warranty against defects in material and workmanship for a period of one year after date of purchase. See printed warranty for details. Pentair will provide a copy of the warranty upon request.

### SPECIFICATIONS

#### Overall Unit Dimensions

38" H x 15" W (20.5" w/prefilter) x 8" D  
[965 mm H x 381 mm W (521 mm W w/prefilter) x 203 mm D]  
[Add 3" (76 mm) on all sides for cover removal and service access]  
(not including storage tanks)

#### Inlet and Outlet Connection

3/8" (9.5 mm) OD tube connection

#### Wastewater Line Connection

1/4" (6.4 mm) OD tube connection

#### Service Flow Rate

Dependent on water pressure in storage tank and line size(s) to equipment

#### Minimum Water Supply

1.0 gpm (3.8 Lpm)

#### Pressure Requirements

Operating:  
25 – 80 psi (1.72-5.52 bar), non-shock  
Maximum Static:  
100 psi (6.89 bar), non-shock

#### Inlet Temperature

40–100°F (4–38°C)

#### Inlet TDS

1,500 ppm max recommended

#### Shipping Weight

35 lbs. (15.9 kg.)  
(not including storage tanks)

#### Electrical

100-240VAC/50-60Hz  
switchable power supply

#### Daily Production Rate

RO Processor Only (No Blend):  
100 gpd (378 Lpd) nominal

#### RO Processor With Blend:

Total daily production rate will vary based on tap water TDS, RO percent rejection and desired blend water TDS - Contact Pentair Everpure for assistance estimating this total



### WATER FILTRATION

EVERPURE-SHURFLO WORLD HEADQUARTERS, 1040 MUIRFIELD DRIVE, HANOVER PARK, IL 60133 USA • FOODSERVICE.PENTAIR.COM  
800.942.1153 (US ONLY) • 630.307.3000 MAIN • 630.307.3030 FAX • CSEVERPURE@PENTAIR.COM EMAIL

EVERPURE-SHURFLO AUSTRALIA, 1-21 MONASH DRIVE, DANDENONG SOUTH, VIC 3175 AUSTRALIA  
011.1300 576 190 TEL • 011.61.39.562.7237 FAX • AU.EVERPURE@PENTAIR.COM EMAIL

EVERPURE-SHURFLO CHINA, 21F CLOUD 9 PLAZA, NO 1118, SHANGHAI, 200052, CHINA  
86.21.3211.4588 TEL • 86.21.3211.4580 FAX • CHINA.WATER@PENTAIR.COM EMAIL

EVERPURE-SHURFLO INDIA, GREEN BOULEVARD, B-9/A, 7TH FLOOR - TOWER B SECTOR 62, NOIDA - 201301  
91.120.419.9444 TEL • 91.120.419.9400 FAX • INDIACUSTOMER@PENTAIR.COM EMAIL

EVERPURE-SHURFLO EUROPE, PENTAIR WATER BELGIUM BVBA, INDUSTRIEPARK WOLFSTEE, TOEKOMSTLAAN 30, B-2200 HERENTALS, BELGIUM  
+32.(0).14.283.504 TEL • +32.(0).14.283.505 FAX • SALES@EVERPURE-EUROPE.COM EMAIL

EVERPURE-SHURFLO JAPAN INC., HASHIMOTO MN BLDG. 7F, 3-25-1 HASHIMOTO, MIDORI-KU, SAGAMIHARA-SHI KANAGAWA 252-0143, JAPAN  
81.(0)42.775.3011 TEL • 81.(0)42.775.3015 FAX • INFO@EVERPURE.CO.JP EMAIL

EVERPURE-SHURFLO SOUTHEAST ASIA, 390 HAVELOCK ROAD, #04-01 KING'S CENTRE, SINGAPORE 169662  
65.6768.5800 TEL • 65.6737.5149 FAX • CSEVERPURE@PENTAIR.COM EMAIL

Pentair trademarks and logos are owned by Pentair plc or its affiliates. Third party registered and unregistered trademarks and logos are property of their respective owners. Because we are continuously improving our products and services, Pentair reserves the right to change specifications without prior notice. Pentair is an equal opportunity employer.