



Profit from the Eagle Advantage®

Specification Sheet

Short Form Specifications

Eagle Microwave Prep Table, model TSM3048C, to consist of three 1448C chrome-plated wire overshelves with 74"-high chrome-plated posts, 30" x 48" stainless steel tabletop, and two 30" x 48" wire undershelves. Inclusive are three supply bins, four display hooks, and two spice racks—all of which mount to rear and side wire grid panels. Five shelf dividers. Four foot glides. Note: Each overshelf can accommodate two standard-size microwaves.



(microwaves not included)

Item No.:	_____
Project No.:	_____
S.I.S. No.:	_____

Microwave Prep Table

MODELS:

TSM3048C

- Flexible design allows for custom look using standard components.
- Three 14" x 48" (356 x 1219mm) wire shelves for overhead storage. Shelf height can be adjusted.
- Five shelf dividers.
- Three plastic supply bins: 10³/₈"L x 5¹/₂"W x 5"D (276 x 140 x 127mm).
- Four 4" (102mm)-long merchandise display hooks.
- Two 14" (356mm)-long spice racks.
- 24" x 48" (610 x 1219mm) front wire grid panel and 12" x 24" side wire grid panel accommodate supply bins, hooks, spice racks, and other hanging accessories.
- 30" x 48" (762 x 1219mm) 18 gauge type 304 stainless steel tabletop.
- Two 30" x 48" (762 x 1219mm) wire undershelves.
- Four foot glides for posts.
- All posts are numbered and grooved at 1" (25mm) increments for fast and level assembly.
- 74" (1880mm) overall post height (rear posts).
- 34" (864mm) working height.
- All metal components are chrome-plated.

EAGLE GROUP

100 Industrial Boulevard, Clayton, DE 19938-8903 USA
 Phone: 302-653-3000 • 800-441-8440 • Fax: 302-653-2065
www.eaglegrp.com
www.eaglegrpnews.com
www.eaglemhc.com

For custom configuration or fabrication needs, contact our **SpecFAB® Division**.
 Phone: 302-653-3000 • Fax: 302-653-2065 • e-mail: quotes@eaglegrp.com



EG01.55 Rev. 06/23

Spec sheets available for viewing, printing or downloading from our online literature library at our websites



Item No.: _____
 Project No.: _____
 S.I.S. No.: _____

Microwave Prep Table

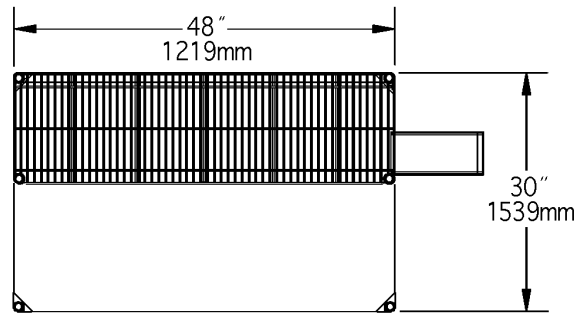

TOP VIEW

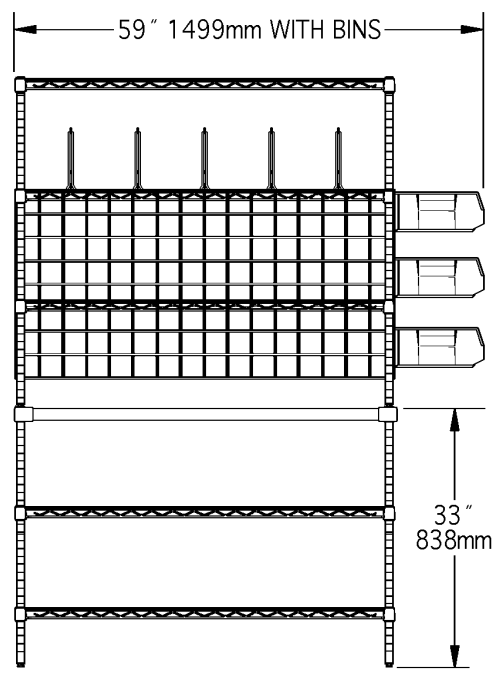

FRONT VIEW

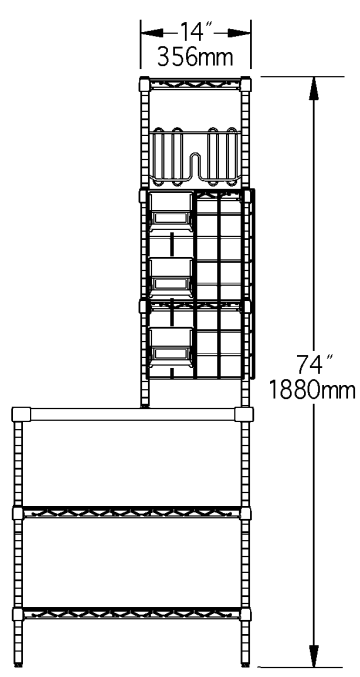

SIDE VIEW

model #	width*		length*		height		weight	
	in.	mm	in.	mm	in.	mm	lbs.	kg
TSM3048C	30"	762	48"	1219	74"	1880	146	66.2

* Excludes wire grid panels and plastic bins.

EAGLE GROUP
 100 Industrial Boulevard, Clayton, DE 19938-8903 USA
 Phone: 302-653-3000 or 800-441-8440 • Fax: 302-653-2065
 www.eaglegrp.com • www.eaglegrpnews.com • www.eaglehmc.com

Printed in U.S.A.
 ©2023 by Eagle Group
 Rev. 06/23

Spec sheets available for viewing, printing or downloading from our online literature library at our websites

Although every attempt has been made to ensure the accuracy of the information provided, we cannot be held responsible for typographical or printing errors. Information and specifications are subject to change without notice. Please confirm at time of order.