

Specification Sheet

Short Form Specifications

BlendPort® EL Series Worktables with Flat Top, model _____ . 18 gauge type 430 stainless steel top features rolled rim on front and rear, with square bend on ends. 1½"-diameter galvanized legs. 18 gauge galvanized undershelf. Adjustable plastic bullet feet.

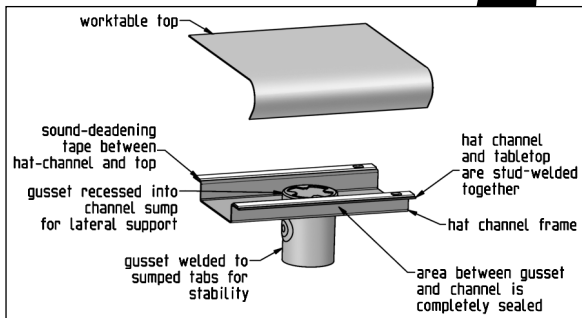

Optional Drawers for EL Series Worktables

16" x 20".
Fully enclosed.
Features roller slides.



description	weight	model #
For 24"-wide tables	21 lbs.	BPD-1620-24T
For 30"-wide tables	26 lbs.	BPD-1620-30T

Item No.: _____
Project No.: _____
S.I.S. No.: _____

BlendPort® EL Series Worktables with Flat Top

- 18 gauge type 430 stainless steel top features hemmed rolled rim edge on front and rear, with square bend on sides, and is sound-deadened.
- Top reinforced with welded-on hat channels, which allow for mounting optional drawers.
- 1½"-diameter galvanized steel legs.
- Galvanized steel gussets.
- Adjustable plastic bullet feet.
- 18 gauge galvanized steel undershelf.

width x length	weight	model #
24" x 24"	39 lbs.	BPT-2424EL
24" x 30"	40 lbs.	BPT-2430EL
24" x 36"	48 lbs.	BPT-2436EL
24" x 48"	56 lbs.	BPT-2448EL
24" x 60"	64 lbs.	BPT-2460EL
24" x 72"	72 lbs.	BPT-2472EL
24" x 96"	92 lbs.	BPT-2496EL
30" x 24"	39 lbs.	BPT-3024EL
30" x 30"	50 lbs.	BPT-3030EL
30" x 36"	52 lbs.	BPT-3036EL
30" x 48"	61 lbs.	BPT-3048EL
30" x 60"	77 lbs.	BPT-3060EL
30" x 72"	86 lbs.	BPT-3072EL
30" x 96"	123 lbs.	BPT-3096EL





Item No.:	_____
Project No.:	_____
S.I.S. No.:	_____

BlendPort® EL Series Worktables with Flat Top

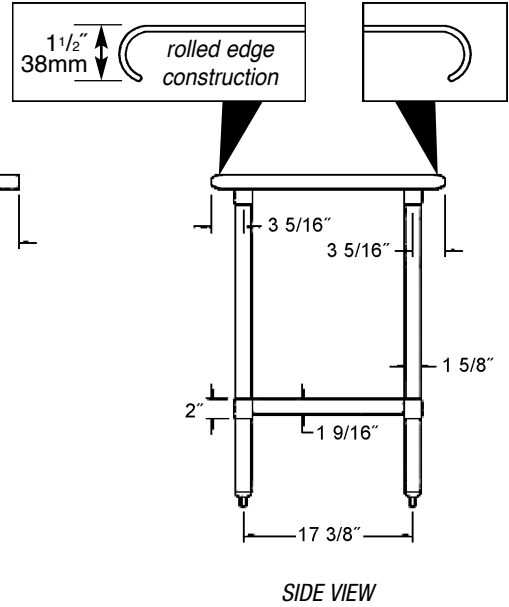
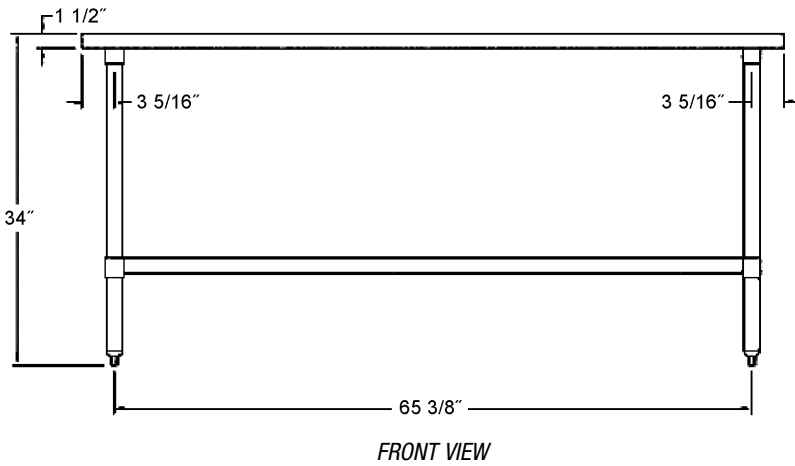
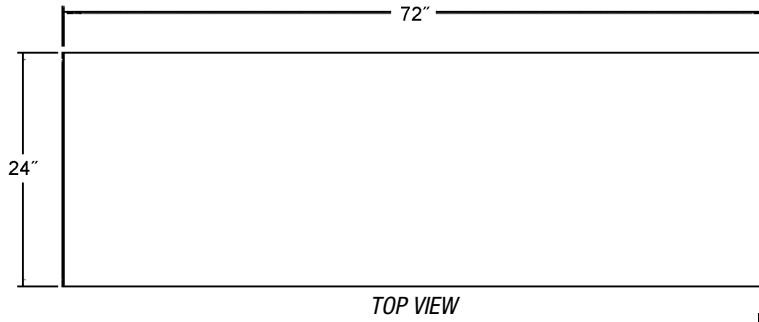

(Note: #BPT-2472EL shown)

BlendPort®

An Eagle Group Company
100 Industrial Boulevard, Clayton, DE 19938-8903 USA
Phone: 800-441-8440 • Fax: 302-653-2065

Printed in U.S.A.
©2023 by Eagle Group
Rev. 03/23

Although every attempt has been made to ensure the accuracy of the information provided, we cannot be held responsible for typographical or printing errors. Information and specifications are subject to change without notice. Please confirm at time of order.