



**MASTERTAP™**  
DRAFT BEER SYSTEMS

# Power Pack Installation Manual

Models KPP20, KPP33, KPP50, KPP75



Power Pack Serial Number(s)

Project	Model No.	Serial No.





# Power Pack

## Installation Instructions



Model No.		KPP20-1	KPP33-1	KPP50-1	KPP50-2	KPP75-1	KPP75-2	KPP75-1-230	KPP75-2-230	KPP75-3-230
<b>Electrical</b>	Voltage	120V	120V	120V	120V	120V	120V	230V**	230V**	230V**
	Frequency	60 Hz	60 Hz	60 Hz	60 Hz	60 Hz	60 Hz	60 Hz	60 Hz	60 Hz
	Phase	1Ø	1Ø	1Ø	1Ø	1Ø	1Ø	1Ø	1Ø	1Ø
	Electrical Connection	Cord & Plug NEMA 5-20P	Cord & Plug NEMA 5-20P	Hard Wire	Hard Wire	Hard Wire	Hard Wire	Hard Wire	Hard Wire	Hard Wire
<b>120V Single Pump</b> (Models ending '-1')	RLA	11A	12.5A	15.3A	-	19.6A	-	-	-	-
	MCA	20A	20A	20A	-	25A	-	-	-	-
<b>120V Double Pump</b> (Models ending '-2')	RLA	-	-	-	21.3A	-	24.5A	-	-	-
	MCA	-	-	-	25A	-	30A	-	-	-
<b>230V Single Pump</b> (Models ending '-1-230')	RLA	-	-	-	-	-	-	11A	-	-
	MCA	-	-	-	-	-	-	20A	-	-
<b>230V Double Pump</b> (Models ending '-2-230')	RLA	-	-	-	-	-	-	-	14A	-
	MCA	-	-	-	-	-	-	-	20A	-
<b>230V Triple Pump</b> (Models ending '-3-230')	RLA	-	-	-	-	-	-	-	-	17A
	MCA	-	-	-	-	-	-	-	-	25A
<b>Length (A)</b>		27"	27"	27"	27"	27"	27"	27"	27"	27"
<b>Width (B)</b>		17"	17"	17"	17"	20"	20"	20"	20"	20"
<b>Height (C)</b>		24-1/2"	24-1/2"	24-1/2"	24-1/2"	26"	26"	26"	26"	26"
<b>Weight</b>		119 lbs	124 lbs	129 lbs	143 lbs	159 lbs	173 lbs	159 lbs	173 lbs	187 lbs
<b>Compressor</b>		1/5 HP	1/3 HP	1/2 HP	1/2 HP	3/4 HP	3/4 HP	3/4 HP	3/4 HP	3/4 HP
<b>Evaporator Rating @ 15° F (BTUH)</b>		1680	2600	4100	4100	6950	6950	6950	6950	6950
<b>Refrigerant</b>		R134A	R134A	R134A	R134A	R134A	R134A	R134A	R134A	R134A
<b>Cabinet Material</b>		Stainless Steel	Stainless Steel	Stainless Steel	Stainless Steel	Stainless Steel	Stainless Steel	Stainless Steel	Stainless Steel	Stainless Steel
<b>Circulating Pump</b>		80 GPH / 100 PSI	80 GPH / 100 PSI	80 GPH / 100 PSI	80 GPH / 100 PSI	80 GPH / 100 PSI	80 GPH / 100 PSI	80 GPH / 100 PSI	80 GPH / 100 PSI	80 GPH / 100 PSI
<b>Reservoir Capacity (gallons)</b>		1.8	1.8	1.8	1.8	1.8	1.8	1.8	1.8	1.8
<b>Refrigerant Charge</b>		12.5 oz.	14 oz.	15.5 oz.	15.5 oz.	20 oz.	20 oz.	20 oz.	20 oz.	20 oz.
<b>Glycol Concentration</b>		33%	33%	33%	33%	33%	33%	33%	33%	33%

RLA = Rated Load Amps  
MCA = Minimum Circuit Ampacity

\*\* 230V models require four wires - 2 hot, 1 neutral, and 1 ground

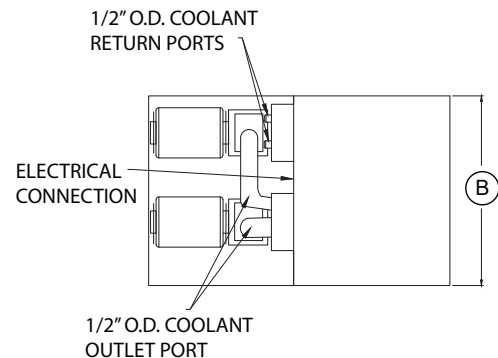
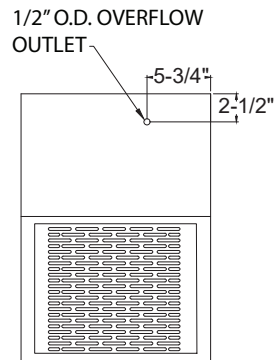
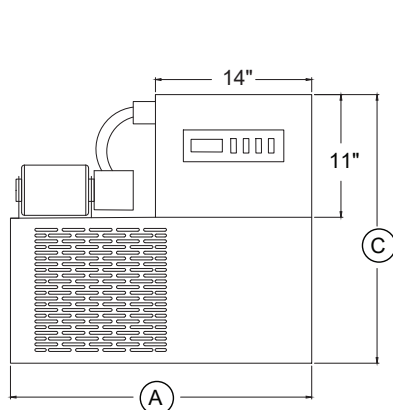



## POWER PACK INSTALLATION

**IMPORTANT: Upon arrival, inspect the crate for any signs of damage occurred during shipment. Contact manufacturer if there is any evidence of damage.**

- Follow all national and local codes during installation
- Observe all safety information to ensure protecting yourself and others during installation or maintenance
- Due to electrical hazards, only properly trained professionals should perform service
- Failure to adhere to safety warnings could result in injury or property damage.
- Never operate the circulating pump without coolant in the reservoir.
- In order to provide ideal performance, Power Packs need proper ventilation to maintain ambient temperatures no more than 100°F. Failure to provide proper ventilation will result in a voided warranty.
- This unit should be operated between 50°F and 90°F ambient temperature for optimal performance.

Before installing the Krowne Power Pack, it is important to determine the way of connecting electricity. It is important the electricity can handle the listed load requirements. Models KPP20 and KPP33 have a cord & plug NEMA 5-20P included. Models KPP50 and KPP75 require hard wiring.

- Determine the placement of the Krowne Power Pack. The Power Pack should be placed as close as possible to the connection point to the trunk housing. Ideal placement is on a dedicated level stand with easy access for service. If a stand is unavailable and the Power Pack needs to be installed on top of a walk-in cooler or on the floor, proper ventilation is required. Failure to provide proper ventilation could result in the Power Pack overheating and causing property damage. If the Power Pack is installed on the floor, use RTF silicone sealant around the edges of the unit to seal to floor.
- Krowne Power Pack should be installed on a level surface and have room for airflow. In regards to airflow, allow at least six inches of clearance on all sides with cut slots to ensure enough air can reach the unit. Also allow additional room on top of the cabinet for service access.
- Remove the front panels on top of Power Pack to make electrical connections (hard wire only)
- Before making electrical connections, ensure power switches for both the compressor and the pump(s) are turned OFF. Make the electrical connections on a dedicated electrical circuit. This electrical circuit should only be used with the Power Pack. Ensure the electrical requirements are met per specifications for the particular Power Pack model. Electrical connection should only be made by trained professionals. Adhere to all national and local codes during electrical connection.
- Plumb the overflow to a drain. Plumbing connections should be made by qualified personnel who will observe all applicable plumbing, sanitary and safety codes.

## START-UP PROCEDURE

1. Remove the back panel on top of the Power Pack to prepare adding the glycol coolant. We recommend using pre-mix glycol coolant supplied by Krowne. If buying glycol from another manufacturer, the glycol coolant must meet FDA regulations as a food grade product. Ensure the glycol coolant you use is 66% water and 33% glycol coolant (2-1) mix. Do not use straight glycol in the reservoir as it can cause severe damage to the pump(s). Begin pouring the glycol coolant mix into the reservoir. Note: Glycol coolant mix needs to be in the reservoir to operate the pumps. Do not operate pumps without glycol coolant mix.
2. Turn ON the pump(s) switch. The glycol coolant mix level in the reservoir will begin to decrease. At this point check all line connections to ensure there are no leaks.
3. If there are no leaks present, continue to add more glycol coolant mix until there are no air bubbles visible and the coolant is level. Do not allow glycol coolant mix level to drop below heat exchanger tube inlet as this could cause air to get into the lines. Fill the reservoir until glycol coolant mix level is just below the overflow port. Check all lines and port connections for coolant leaks.
4. Turn ON the compressor switch. Monitor temperature to ensure Power Pack is working properly.
5. Before introducing beer into the system, allow for the bath to reach 32°F and ensure the beer is between 36°F and 38°F.



## HOW TO INSTALL COOLANT CONNECTOR TO POWER PACK

1. Check pump's outlet port for debris. Insert barbed fitting into pump's outlet port.
2. Check Glycol Return Manifold inlet for debris. Insert barbed fitting into return manifold inlet port.
3. Clamp the blue coolant connector lines to the pump outlet fitting(s) and the red coolant connector lines to the return manifold fitting(s)
4. Secure insulation sleeves against connection points. Use insulation tape where necessary to ensure an air tight seal.
5. Drill a 3-1/2" diameter hole in the walk-in cooler 1" from the trunk line hole for the coolant connector to pass through. If this is not possible, drill the 3-1/2" hole as close to where the trunk line exits the walk-in cooler.
6. Insert coolant connector through 3-1/2" hole previously cut in walk-in cooler wall.
7. Cut off excess coolant connector not needed.
8. Position coolant connector in a horizontal position to avoid condensation runoff into trunk insulation.
9. Utilizing 1/2" U bends, tie in the coolant connector to the trunk line by clamping one red glycol line from the trunk line on one side of one of the U bends and the red glycol line from the coolant connector on the other side of the U bend. Do the same with the other U bend, but with the blue glycol lines.
10. Using foam tape, insulate all glycol lines and U bends.
11. Wrap foam tape in waterproof tape to waterproof insulation and ensure foam tape stays intact.
12. Seal hole in walk-in cooler.
13. Ensure no glycol tubing is exposed. Exposed glycol tubing will condensate.

## DIGITAL TEMPERATURE CONTROLLER

The Krowne Power Pack includes a Digital Thermostat with display. To ensure optimal performance, there are numerous factory settings on the Digital Thermostat that should not be adjusted, most importantly the default setting to cut-out at 30°F with a differential of 2°F.

### SETTING THE SET POINT

#### How to see the Set Point:

- Push and release SET for 3 seconds and the display will show the Set point value.

#### How to change the Set Point:

1. Push and hold SET for more than 3 seconds to change the set point value.
2. The value of the set point will be shown and start blinking.
3. To change the set value, push the UP or DOWN arrows to the desired value.
4. To save the new set point value, push and hold SET again for 3 seconds

		Standard Cooler Setting
Factory Settings	Set Point	30°F
	Operating Range	28°F to 34°F
Range of Adjustment	Minimum Set Point	28°F
	Maximum Set Point	34°F

### Digital Temperature Alarms:

Code	Error
E0	Glycol Return Temp Sensor
E2	High Pressure or Low Pressure Swtich



## MAINTENANCE

- Maintenance should be done by trained service professionals.
- Condenser should be cleaned every 90 days.
- Replace glycol coolant mix every 12-18 months to ensure the glycol to water ratio is accurate. Ensure the glycol coolant is 66% water and 33% glycol coolant (2-1) mix.
- Check glycol water solution to ensure it is at the proper level.
- Check all coolant connections for leaks.

## REPLACEMENT PARTS

Component	KPP20-1	KPP33-1	KPP50-1	KPP50-2	KPP75-1	KPP75-2	KPP75-1-230	KPP75-2-230	KPP75-3-230
<b>Condensing Fan Motor</b>	BC-946	BC-946	BC-947	BC-947	BC-948	BC-948	BC-949	BC-949	BC-949
<b>Pump Motor</b>	BC-923	BC-923	BC-924	BC-924	BC-924	BC-924	BC-926	BC-926	BC-926
<b>Glycol Pump</b>	BC-978	BC-978	BC-978	BC-978	BC-978	BC-978	BC-978	BC-978	BC-978
<b>Digital Controller</b>	BC-535	BC-535	BC-535	BC-535	BC-535	BC-535	BC-958	BC-958	BC-958
<b>Temperature Sensor</b>	BC-959	BC-959	BC-959	BC-959	BC-959	BC-959	BC-959	BC-959	BC-959
<b>Manifold</b>	BC-938	BC-938	BC-938	BC-938	BC-938	BC-938	BC-938	BC-938	BC-938
<b>High Pressure Switch</b>	BC-997	BC-997	BC-997	BC-997	BC-997	BC-997	BC-997	BC-997	BC-997
<b>Low Pressure Switch</b>	BC-998	BC-998	BC-998	BC-998	BC-998	BC-998	BC-998	BC-998	BC-998
<b>Glycol Premix</b> (33% Glycol / 67% Distilled Water)	GL-1	GL-1	GL-1	GL-1	GL-1	GL-1	GL-1	GL-1	GL-1

Please contact our customer service team if you need assistance choosing the correct replacement parts.  
customerservice@krowne.com • (800) 63 1-0442

## ACCESSORIES

Accessory	KPP20-1	KPP33-1	KPP50-1	KPP50-2	KPP75-1	KPP75-2	KPP75-1-230	KPP75-2-230	KPP75-3-230
<b>Stand for Power Pack</b>	KPP-S1	KPP-S1	KPP-S1	KPP-S1	KPP-S1	KPP-S1	KPP-S1	KPP-S1	KPP-S1
<b>Wall Bracket for Power Pack</b>	KPP-W1	KPP-W1	KPP-W1	KPP-W1	KPP-W1-75	KPP-W1-75	KPP-W1-75	KPP-W1-75	KPP-W1-75

**Note:** The Wall Bracket comes in two sizes (KPP-W1 & KPP-W1-75). Refer to the above chart for the appropriate model. The Stand (KPP-S1) fits all Power Packs.



Conforms to UL STDS 60335-1 & 60335-2-89  
Certified to CSA STD C22.2 #s 60335-1 & 60335-2-89

## Wire Diagram for Models KPP20, KPP33, KPP50 (120V)

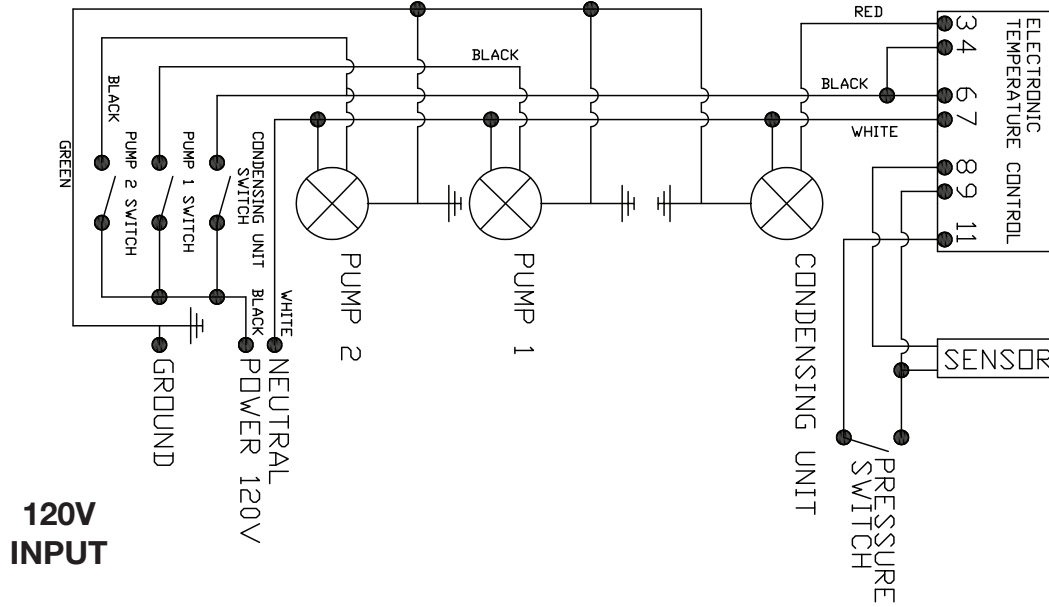

## Wire Diagram for Models KPP75 (120V)

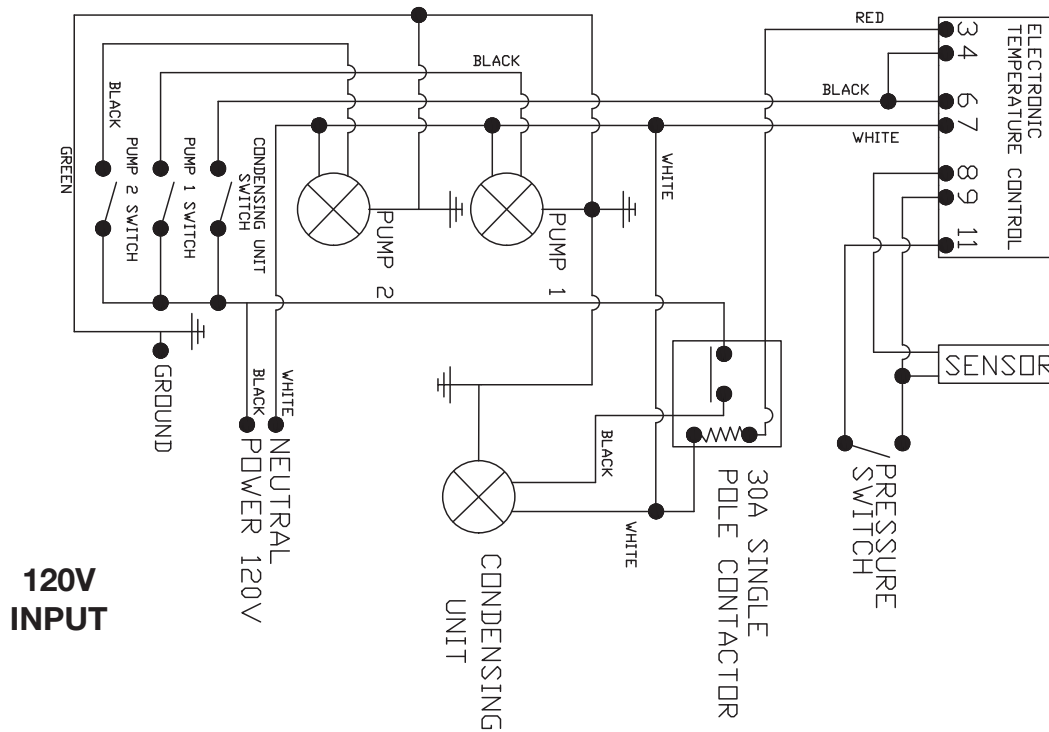

## Wire Diagram for Models KPP75 (230V)

(230V models require four wires - 2 hot, 1 neutral, and 1 ground)

