

## BEVERAGE CENTER

Compliant with  
NSF/ANSI Standard 2



DXPR3BCI

### Item Numbers

DXPR2BCI  
DXPR3BCI  
DXPR4BCI

The Dinex Beverage Cooler is good for back bar or self service ice units for beverages. These units are designed to serve a variety of refrigerated food products and are ideal as a salad bar merchandiser. The versatile modular design allows you to do stand alone kiosks, cafeteria or a buffet unit. Units are compatible and will interlock with other Mobile Serving Cart units.

### Standard Features

- Seamless, molded FRP body with smooth exterior and rounded corners
- 14-gauge stainless steel top with fully welded square turndowns on all sides
- Enclosed base
- 20-gauge stainless steel fully welded 5" deep cold pan
- Welded, watertight well
- Cold pan has a 3/4" FPT drain ball valve located below the unit
- 4" diameter swivel plate casters with brakes
- Interlocking mechanism is provided to interlock with other Reflections units

### Dimensions

DXPR2BCI – 36"H x 30"D x 36"L  
DXPR3BCI – 36"H x 30"D x 50"L  
DXPR4BCI – 36"H x 30"D x 60"L

### Standard Colors

- Wine Red (RAL 3005)
- Signal Red (RAL 3001)
- Yellow (RAL 1021)
- Light Blue (RAL 5012)
- Gentiane Blue (RAL 5010)
- Water Blue (RAL 5021)
- Moss Green (RAL 6005)
- Squirrel Gray (RAL 7000)
- Black
- White
- Custom colors available
- Optional Graphics Packages available

### Warranty

One year parts and labor.

*We do not accept returns on any Dinex equipment or Dinex custom products.  
Please contact your local Dinex rep to ensure order accuracy prior to ordering.*

# DINEX®

4711 E. Hefner Road  
Oklahoma City, OK 73131  
800.654.8210 | 405.475.5600  
www.dinex.com

Rev 04/2020

# BEVERAGE CENTER

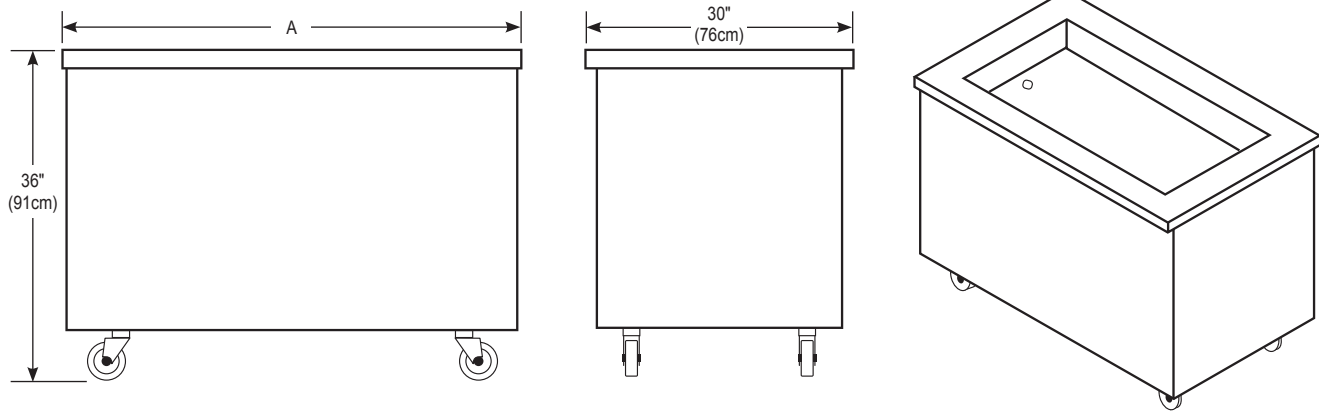

## Items and Dimensions

ITEM NUMBER	LENGTH (A)	DEPTH	HEIGHT*	CAPACITY**	MAX PAN CAPACITY (12" X 20" PAN)	SHIP WEIGHT	SHIP CUBE
DXPR2BCI	36" (91cm)	30" (76cm)	36" (91cm)	80	2	350 lbs 159kg	22.50
DXPR3BCI	50" (127cm)	30" (76cm)	36" (91cm)	120	3	485 lbs 220kg	31.25
DXPR4BCI	60" (152cm)	30" (76cm)	36" (91cm)	160	4	500 lbs 227kg	37.50

\* Height includes casters

\*\* Based on 12 oz. bottles. Capacities vary depending on product and ice usage.

## Options

ITEM NO	DESCRIPTION
DXPROHS	Overhead Shelf
DXPRSES	Stainless Steel End Shelf, Drop Type
DXPROU	Open Understorage with Shelf

Please confirm that you have the most current specification sheet by visiting [www.dinex.com](http://www.dinex.com).

It is Dinex's policy to offer equipment which is design certified by companies that have been accredited at the federal level by the Occupational Safety and Health Agency (OSHA) and ANSI as a national recognized testing laboratory. These companies include CSA International, Underwriters Laboratories, Edison Testing Laboratories and National Sanitation Foundation. However, a continuing program of product improvement makes it necessary to submit new models to the agencies as they are developed. Consequently, all models may not bear the appropriate labels at all times.

Dinex reserves the right to change specifications and product design without notice. Such revisions do not entitle the buyer to corresponding changes, improvements, additions or replacements for previously purchased equipment.

