



SPEC SHEET

KoolMore 27 in. One-Door Commercial Undercounter Freezer

SKU: KM-UCF-1DSS

FEATURES

- ETL Listed for Safety and Sanitation
- Fully insulated polyurethane insulation for energy efficiency
- Utilizes R290 refrigerant for eco-friendly operation
- Internal lighting for enhanced visibility



CLOSE UP IMAGES



TECHNICAL SPECS

Dimensions

Depth	27
Width	29.5
Height	35.2
Interior Depth	19.8
Interior Width	22.3
Interior Height	23.5
Shelf Width	21.9
Shelf Depth	17.7
Depth Including Handles	29.5
Depth Excluding Handles	29.5
Depth Less Door	54.6
Depth With Door Open 90 Degrees	54.6
Power Cord Length	98.5

Capacity

Weight	158.4
Gross Cubic Feet	6.3
Net Capacity Cu. Ft.	5.4
Individual Shelf Capacity	88 lbs.
Top Capacity	550

Features & Material

Door Style	Swing
Number Of Doors	1
Number Of Shelves	1
Defrost Type	Automatic
Refrigerant Type	R290
Temperature Control Type	Digital
Ambient Temperature Range	100 F
Temperature Range	-8-0F
Casters	4
Light Type	NA
Shelf Material Type	Plastic Coated
Interior Material	SS 201
Exterior Material	SS 430

Electric Data & Certifications

Amps	3.6
Phase	1
Plug Type	NEMA 5-15P
Voltage	115
Hertz	60
Wattage	235
Horsepower	0.4352
Certifications	ETL Listed for Safety and Sanitation

Plan View

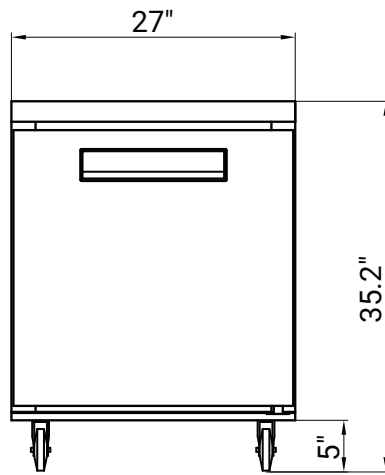

ELEVATION

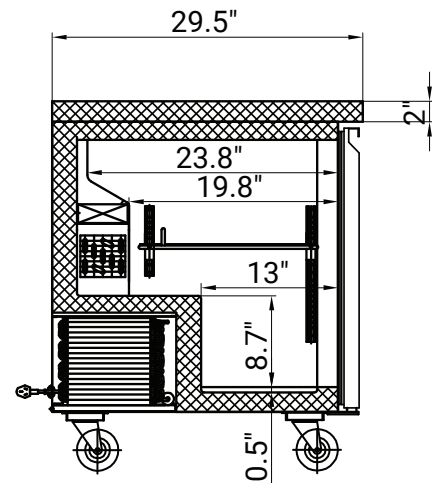

SECTION VIEW

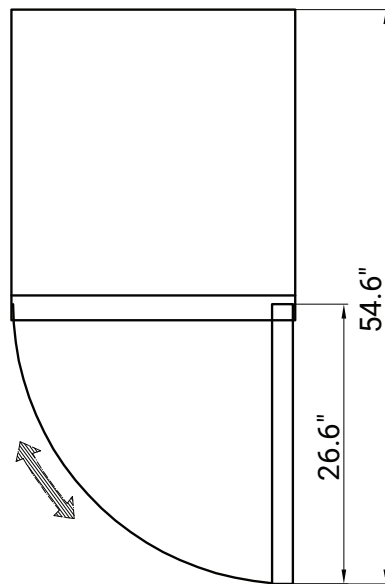

PLAN

CERTIFICATIONS



Intertek



Intertek



706 Eastern Parkway STE 1G, Brooklyn NY 11213
718-576-6342
info@koolmore.com