



COOKER/MIXERS

FLOOR MOUNTED TWIN SHAFT AGITATOR GAS MODEL DHT

Cooker/Mixer Kettle shall be a Groen Model DHT-40 or 60 (C,A), TA/3 (specify 40- or 60-gallon) stainless steel, self contained 2/3 steam jacketed unit operating from a gas-heated steam source contained within unit, complete with console-mounted tilt-out twin shaft scraper mixer.

AVAILABLE MODELS:

- DHT-40C TA/3 (40 GALLON)
- DHT-40A TA/3 (40 GALLON)
- DHT-60C TA/3 (60 GALLON)
- DHT-60A TA/3 (60 GALLON)

CONSTRUCTION: Kettle interior shall be of type 316 stainless steel, solid one-piece welded construction. The control console and kettle exterior shall be 304 stainless steel. The kettle body shall be mounted on a heavy-duty stainless steel, combination kettle support tilt trunnion, which, is supported by the polished stainless steel enclosed base. The kettle shall be furnished with heavy-duty reinforced rim with a butterfly-shaped pouring lip for maximum sanitation and ease of pouring. The base shall be provided with stainless steel tubular legs with adjustable bullet feet. The enclosed support base shall contain a self-locking worm and gear tilt mechanism, controls, etc., and shall be of sanitary, drip-proof construction with interior readily accessible for installation or maintenance. Unit includes 2" TDO, 10-Gallon etch markings and double pantry faucet.

AGITATOR ASSEMBLY: Enclosed transfer case to be cast aluminum with a 3- to-1 gear ratio. Gear motor to be completely enclosed-type, cast iron housing, right angle shaft down, helical bevel gearing, variable-speed motor driven through an electronic speed control. See table on back for minimum and maximum agitator speeds. Main agitator to be anchor type, shaped to the contour of the kettle and provided with removable nylon finger scrapers. The secondary counter-rotating bar type agitator shall be centrally-located between the center shaft and the outside arms of the main agitator. Both agitators are attached with bayonet connections for easy, quick removal for cleaning or when kettle is to be used without the mixing mechanism. Both agitators are 304 stainless steel and either can be used alone. Agitator and motor drive assembly can be manually tilted to the right side of the kettle.

FINISH: Kettle interior shall be polished to a 180 emery grit finish. Kettle exterior shall be finished to a bright semi-delux finish, ensuring maximum ease in cleaning and maintaining brilliant appearance.

ASME CODE AND CSA

CERTIFICATION: Unit shall be ASME shop-inspected, stamped and registered with the National Board for operation up to a maximum working pressure of 50 PSIG. Kettle shall be design certified by CSA America for use with natural gas or LP gas.

SANITATION: Unit shall be designed and constructed to be NSF listed, meeting NSF requirements.

SELF-CONTAINED STEAM SOURCE:

Kettle shall have an gas-heated (natural or propane), self-contained steam source to provide kettle temperatures of 150°F to approximately 295°F. Unit shall be factory-charged with water and rust inhibitors to ensure long life and minimum maintenance.

CONTROLS: Controls to be located in right-side water resistant (IPX6 rated) trunnion enclosure:

Classic -C Models include: Power ON-OFF switch with indicator light, temperature control knob with 1 to 10 increments, HEAT(ing) indicator light and LOW WATER warning light. **Advanced -A Models** include: Power ON-OFF switch with indicator light, temperature & time set knob, HEAT(ing) indicator light, LED display of set heat level or cook time, buttons for reset of Low Temp and High Temp presets, MANUAL mode button for knob-setting of heat level, and TIMER set button with indicator light. The agitator has on-off and variable speed control switch.

SAFETY FEATURES: Kettle shall have safety cut-off (turns off heat when tilted to an angle above 10 degrees), pressure relief valve, high limit pressure switch and low water cut-off, 24Volt control system and agitator safety tilt cut-off.

INSTALLATION REQUIREMENTS: Specify natural or propane gas. Unit requires 1/2 " NPT gas line connection, 115Volt, 60Hz power for kettle and 208 Volt (3-phase only) power for agitator motor. No remote steam source required.

ORIGIN OF MANUFACTURE: Designed and manufactured in the United States.

PROJECT NAME:

LOCATION:

ITEM NO:

QTY:

MODEL NO:

AIA NO:

SIS NO:



OPTIONS/ACCESSORIES:

- Disk Strainers (Not to be used with agitator)
- 240, 480 Volt Power Supply
- Kettle Brush Kit
- Pan Carrier
- Gallon Master
- Basket Insert
- Lip strainers
- Contour measuring strips



P/N 176806 REV A

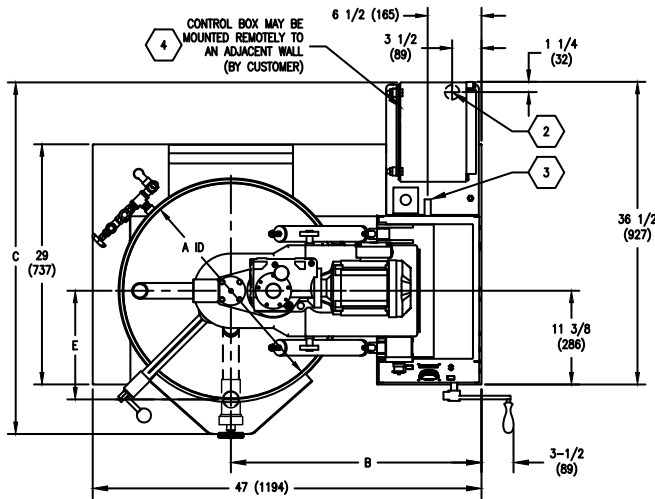

| KETTLE FIRING RATE FOR BOTH NATURAL & PROPANE GAS | |
|---|------------------|
| 40 GAL. (150 L) | 100,000 (BTU/HR) |
| 60 GAL. (230 L) | 150,000 (BTU/HR) |

| OPERATING GAS PRESSURE | |
|------------------------|-----------|
| NATURAL GAS | PROPANE |
| 3.5 W.C. | 10.0 W.C. |

| INCOMING GAS PRESSURE | | |
|-----------------------|-------------------|-------------------|
| GAS TYPE | MIN. GAS PRESSURE | MAX. GAS PRESSURE |
| NATURAL | 4.5 W.C. | 14.0 W.C. |
| PROPANE | 11.0 W.C. | 14.0 W.C. |

| TABLE OF DIMENSIONS | | | | |
|---------------------|---------------|---------------|--------|------|
| MODEL | 40 GAL. 150 L | 60 GAL. 230 L | | |
| DIM. | INCH | MM | INCH | MM |
| A | 26 | 660 | 30 | 762 |
| B | 30 1/4 | 768 | 32 1/4 | 819 |
| C | 42 3/4 | 1086 | 44 1/4 | 1124 |
| D | 46 7/8 | 1191 | 50 1/4 | 1276 |
| E | 13 1/8 | 333 | 13 1/8 | 333 |
| F | 34 3/4 | 883 | 38 1/2 | 978 |
| G | 13 7/8 | 352 | 17 5/8 | 448 |
| H | 54 7/8 | 1393 | 59 1/4 | 1505 |
| J | 57 1/2 | 1460 | 61 1/2 | 1562 |
| K | 73 | 1854 | 81 1/2 | 2070 |
| L | 3 7/8 | 352 | 18 3/4 | 476 |
| M | 11 3/4 | 298 | 10 1/4 | 260 |

NOTES:

- ELECTRICAL POWER CONNECTIONS, KETTLE 7/8" DIAMETER HOLE (BACK SIDE). 115 VOLT/1PH/60HZ, 5 AMPS
- ELECTRICAL POWER CONNECTION, AGITATOR 1-3/4" DIAMETER HOLE (BOTTOM SIDE).
- GAS INLET CONNECTION, KETTLE 1/2" NPT.
- AGITATOR MOTOR SPEED SELECTOR SWITCH.
- CONTROL BOX MAY BE REMOTELY MOUNTED (BY CUSTOMER) IF DESIRED.

| | AGITATOR MOTOR SPEED | | ELEC. LOAD RATING | | | | |
|--------|----------------------|---------------|-------------------|----------|----------|----------|-------|
| | RPM MAIN | RPM SECONDARY | H.P. | 208V 3PH | 240V 3PH | 480V 3PH | |
| 40 GAL | MAXIMUM | 36 | 100 | 1-1/2 | 5.3 A | 4.8 A | 2.4 A |
| | MINIMUM | 8 | 22 | 3/4 | 3.1 A | 2.8 A | 1.4 A |
| 60 GAL | MAXIMUM | 36 | 100 | 2 | 6.9 A | 6.2 A | 3.1 A |
| | MINIMUM | 8 | 22 | 1 | 4.0 A | 3.6 A | 1.8 A |

