



Food Truck Wash Station

Food Truck

RESOURCES

Certifications:



Features:

- Three Compartment Sink & Hand Washing Sink with Side Splashes All in One Station
- Perforated Removable Drain Board
- Mountable Flange Feet Adjustable up to 1.25"
- Hinged Doors to Access Storage
- Storage Space: 27"l x 44 3/4" w x 16" h to bottom of bowls (drains will affect spacing)
- Standard Unit - Hard plumbing
- M in the model number denotes it is a mobile unit
- Mobile Unit - Water heater, Fresh & Waste Water Tank
- Plug Style 5-15p
- Hot Water Units: Watts 1474, Amps 14.8
- Cold Water Units: Watts 33.6, Amps 2.8

Material:

- 14 ga. T-304 Stainless Steel Top
- 18 ga. T-304 Stainless Steel Body
- Stainless Steel Legs



Use your smart phone to scan the above QR code to visit our website:
www.bk-resources.com



Part Number	Overall Dim. (l x w x h)	Bowl Size Hand Sink (lxwxh)	Fresh Water Capacity	Grey Water Capacity	Water Pump Voltage	Water Pump Flow Rate	Water Heater Voltage	Water Heater Capacity
FTWS-4829L	29" x 48" x 42 1/8"	9" x 9" x 5"	-	-	-	-	-	-
FTWS-M-4829L	29" x 48" x 42 1/8"	9" x 9" x 5"	5 Gallons	21 Gallons	12 V	3.3 GPM	120 V	2.5 Gallons

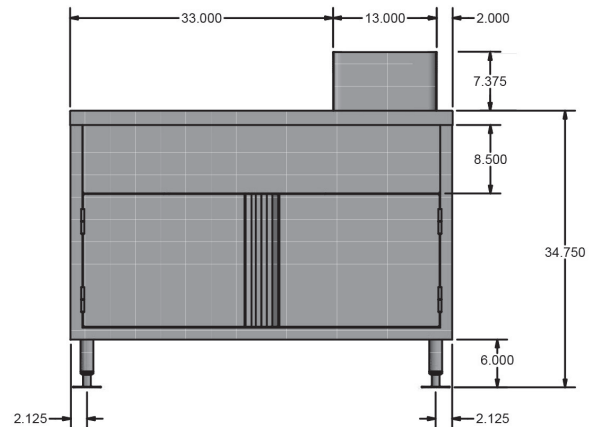
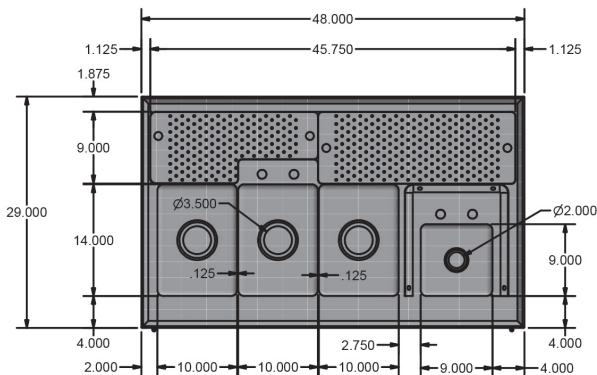
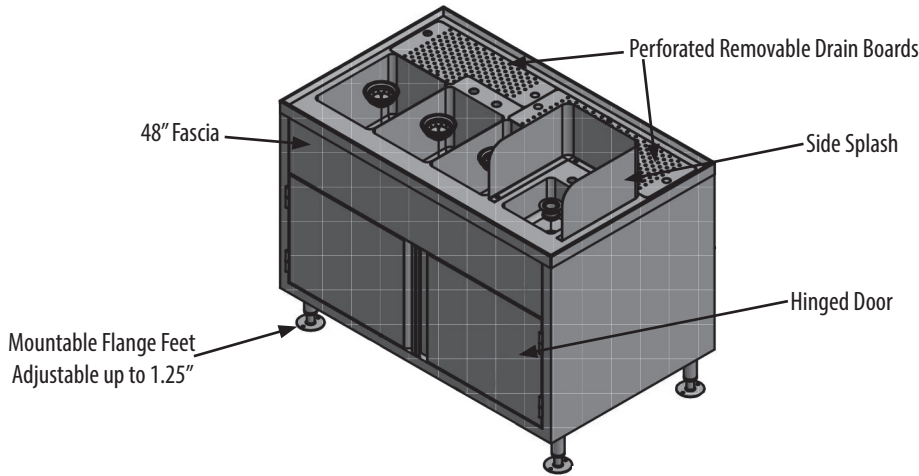

PRODUCT DATA SHEET