

APPLICATION:

JOB NAME:

QUANTITY:                      ITEM NO.

PRODUCT NAME:  
**ATMOSPHERIC VACUUM BREAKER**

\_\_\_\_\_ SPECIAL CONFIGURATION  
 CHECK BASE MODEL AND OPTIONS

MODEL:  
 3990

OPTIONS OR MODIFICATIONS:  
 SUPPLY LINES (24" OR 36") CIRCLE LENGTH  
 OTHER \_\_\_\_\_

**FEATURES**

- \* ATMOSPHERIC VACUUM BREAKER
- \* LEDGE MOUNT

**SYSTEM LIMITS**

- \* TEMP: 40°F MIN. TO 140°F MAX.
- \* PRESSURE: 200 PSI MAX. STATIC

**SHIPPING WEIGHT**

- \* 3.5 LBS

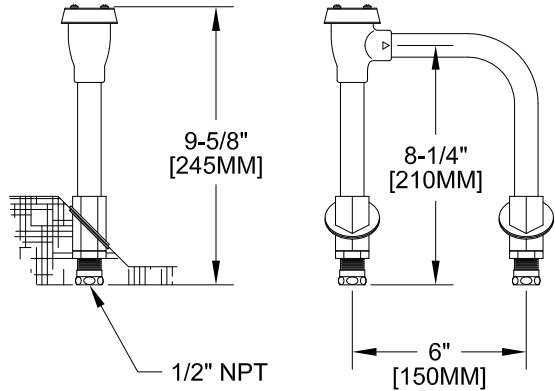

ROUGH-IN:

