

# Specification Sheet

## Short Form Specifications

BlendPort® Bottle Coolers, model \_\_\_\_\_.  
 Foamed-in-place high density polyurethane insulation. Steel cabinet exterior wrapped in durable black vinyl. Top features stainless steel full-length countertop with 1/2" polymer edge, and lockable stainless steel sliding covers, each with extruded pull handles. Comes with removable bottle opener and cap catcher (#BPR-JBC-95 has two), painted aluminum interior, and plastic coated stainless steel dividers (except #BPR-JBC-25). Easily accessible condensing unit. Self-contained refrigeration. Forced-air cooling. Auto defrost. 8-ft. cord and NEMA 5-15 plug.



Item No.:	_____
Project No.:	_____
S.I.S. No.:	_____

## Bottle Coolers

### MODELS:

- BPR-JBC-25
- BPR-JBC-50
- BPR-JBC-65
- BPR-JBC-95

### Design & Construction Features

- Stainless steel countertop with 1/2" polymer edge.
- Lockable stainless steel sliding covers.
- Black vinyl-clad cabinet.
- Painted aluminum interior.
- Lengths available range from 26 3/4" to 95".
- Includes removable bottle opener and cap catcher\*.
- 8' cord with NEMA 5-15P plug.
- 120-volt, 60-cycle, single-phase
- Self-contained refrigeration maintains temperatures at 33°F to 41°F.
- Forced-air cooling.
- Auto defrost\*\*.
- One year parts and labor warranty and five year compressor warranty.

\* #BPR-JBC-95 features two removable bottle openers & cap catchers.

\*\* Auto frost included on all units except #BPR-JBC-25

Item No.:	_____
Project No.:	_____
S.I.S. No.:	_____

# Bottle Coolers

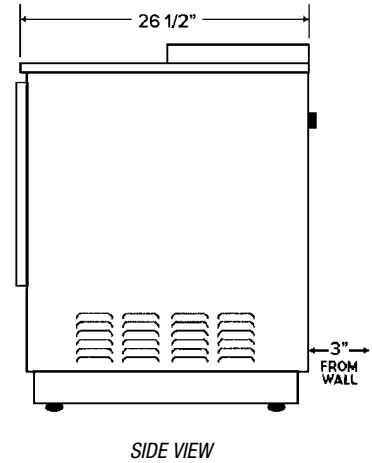
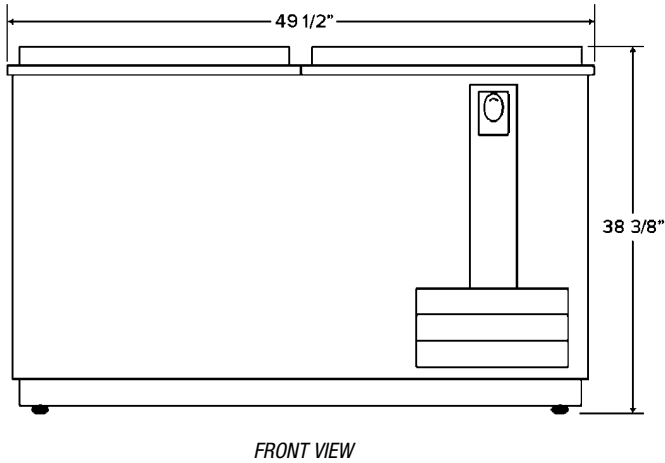
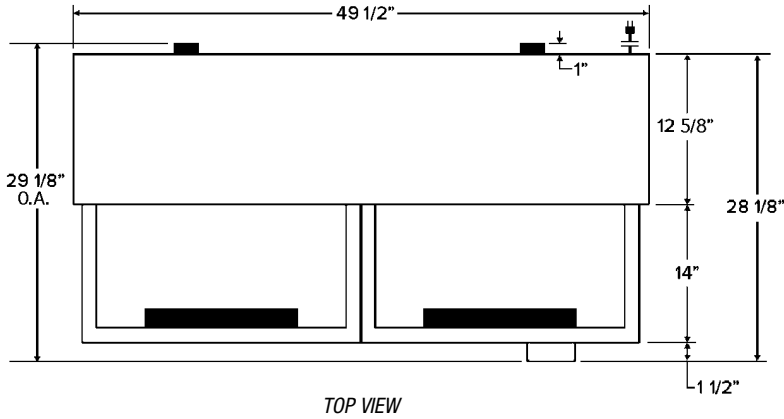

(MODEL #BPR-JBC-50 SHOWN)

width*		length		height		# of sliding covers	capacities		electrical data**	weight	model #
in.	mm	in.	mm	in.	mm		12-oz. btls	12-oz. cans			
26 <sup>5</sup> / <sub>8</sub> "	676	26 <sup>5</sup> / <sub>8</sub> "	677	33 <sup>3</sup> / <sub>8</sub> "	848	1	5 cases	7 cases	1/5-HP, 120V, 2.3A	186 lbs.	<b>BPR-JBC-25</b>
26 <sup>5</sup> / <sub>8</sub> "	676	49 <sup>1</sup> / <sub>2</sub> "	1257	33 <sup>3</sup> / <sub>8</sub> "	848	2	16 <sup>1</sup> / <sub>2</sub> cases	24 cases	1/3-HP, 120V, 8.0A	304 lbs.	<b>BPR-JBC-50</b>
26 <sup>5</sup> / <sub>8</sub> "	676	64 <sup>1</sup> / <sub>2</sub> "	1638	33 <sup>3</sup> / <sub>8</sub> "	848	2	24 cases	32 cases	1/3-HP, 120V, 8.0A	348 lbs.	<b>BPR-JBC-65</b>
26 <sup>5</sup> / <sub>8</sub> "	676	95"	2413	33 <sup>3</sup> / <sub>8</sub> "	848	3	37 <sup>1</sup> / <sub>2</sub> cases	55 cases	1/2-HP, 120V, 8.7A	464 lbs.	<b>BPR-JBC-95</b>

\* Excludes bottle opener at front and bumper at rear.  
\*\* All units are 60-cycle single-phase.

All units feature one-year parts and labor warranty and five-year compressor warranty.

## BlendPort<sup>®</sup>

An Eagle Group Company  
100 Industrial Boulevard, Clayton, DE 19938-8903 USA  
Phone: 800-441-8440 • Fax: 302-653-2065

Printed in U.S.A.  
©2023 by Eagle Group  
Rev. 03/23

Although every attempt has been made to ensure the accuracy of the information provided, we cannot be held responsible for typographical or printing errors. Information and specifications are subject to change without notice. Please confirm at time of order.