

## Special Features:

- ✓ Restaurant Range
- ✓ 36" Wide Range Top
- ✓ Stainless Steel Construction
- ✓ High Rise Stainless Steel Backsplash and Shelf
- ✓ 6 Total Top Range Burners
- ✓ Insulated Stainless Steel Oven Door with Ceramic Coating
- ✓ Welded Frame Structure Provides Stability
- ✓ 1 U-Shaped Oven Burner
- ✓ Pull Out Crumb Tray With Angled Front Handle
- ✓ 6" Adjustable Stainless Steel Legs
- ✓ Kick Plate at the Bottom for Easy Access for Servicing
- ✓ Cooling Switch Rapidly Reduces Oven Temp.
- ✓ Standby Stainless Steel Pilot for Easy Burner Operation

## Main Description:

The Empura EGR-36C\_LP is a 36" wide gas range with with (6) 12" x 12" 30,000 BTU top burners and (1) 31,000 BTU convection oven with a temperature range of 250°F to 490°F. The gas range includes a 24 1/2" high stainless steel backriser with a stainless steel shelf and a 4" front ledge that provides plenty of working space. This model features a welded frame construction for stability and stands on sturdy 6" adjustable stainless steel legs.

**Intended For Commercial Use Only.** Empura assumes no liability for component failure, factory defects or any other damages for units installed in non-commercial foodservice or residential applications.

## Group Description:

Empura Gas Ranges are an economical choice when you are looking to outfit, replace, or expand your commercial kitchen. Heavy duty construction, cast iron open burners, and built-in ovens make these restaurant ranges a solid, workhorse when you're making soups, stews, pastas, veggies, roasts, breads and more. You can count on an Empura Gas Range for almost any commonplace cooking task you may need accomplished.



**TECHNICAL SPECS**

**Dimensions**

Overall Width	36"
Overall Depth	35"
Overall Height	56 1/2"
Oven Interior Width	26 5/8"
Oven Interior Depth	23 3/4"
Oven Interior Height	13 3/4"

**Construction**

Control Type	Manual
Gas Inlet Size	3/4"
Installation Type	Freestanding
Number of Racks	2
Back Shelf Depth	10"
Front Ledge Depth	4"
Heavy Duty Legs	6"/Stainless Steel/Adjustable
Shipping Weight	545 lb.

**Cooking**

Power Type	Liquid Propane
Number of Burners	6
Burner Style	Grates
Burner BTU/each	30,000 BTU
Range Base Style	Standard Oven
Number of Ovens	1
Maximum Temperature	490°F
Oven BTU/each	31,000 BTU
Total BTU	211,000 BTU

**Griddle**

Griddle Position	N/A
Griddle Width	N/A
Griddle Cooking Surface Size	N/A
Griddle Plate Thickness	N/A
Griddle BTU	N/A

**UNIT VIEW**

**Front View**

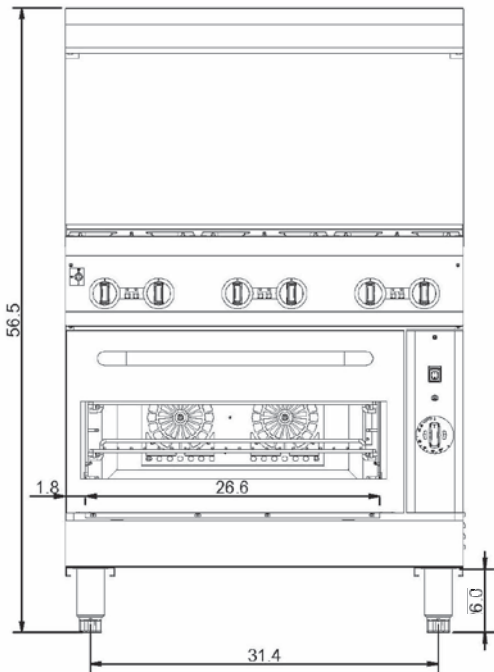

**Side View**

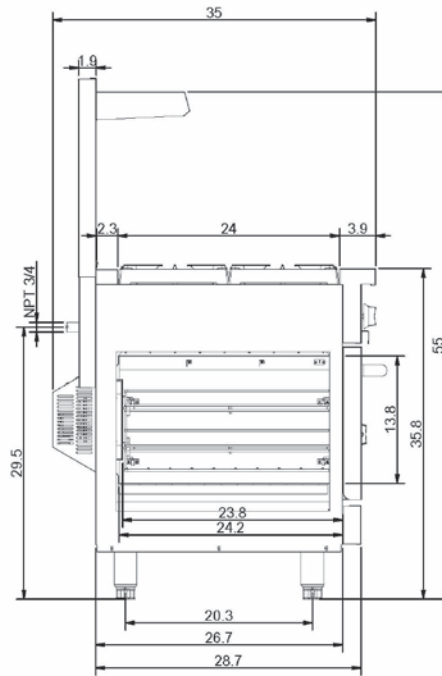

**Top View**

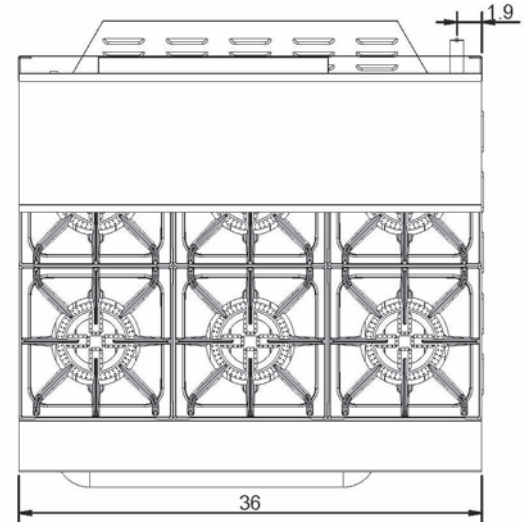

**Attention CA Residents:** This product can expose you to chemicals including lead, which are known to the State of California to cause cancer, birth defects, or other reproductive harm. For more information, go to [www.p65warnings.ca.gov](http://www.p65warnings.ca.gov).



**3/4" Gas Connection:**  
This unit comes with a 3/4" gas connection.



**Fuel Type:**  
This unit is made for use with liquid propane.