

TITAN STAINLESS

CUSTOM FOODSERVICE FABRICATION

502 Usher Street · Pageland, SC · 704-243-8717 · www.titan-stainless.com



EQUIPMENT STAND WITH OPEN BASE

TITAN STAINLESS equipment stands are made using all-welded heavy gauge stainless steel construction. Assembly is not required; however, equipment can be disassembled for convenience. The top is turned up 2" at the rear and both sides to keep equipment in place. The front edge features our standard nosing: 1-1/2" flange down with 1/2" return at 45°. Reinforcing channels are applied to the underside of the top and sealed with double-sided sound dampening tape. 1-5/8" diameter tubing is fitted into stainless steel leg sockets, which are welded to reinforcement below, preventing surface imperfections. Legs are removable, and furnished with adjustable stainless steel bullet feet. 1-5/8" diameter cross-rails are welded to the table legs. All welds are ground and polished to a smooth finish.

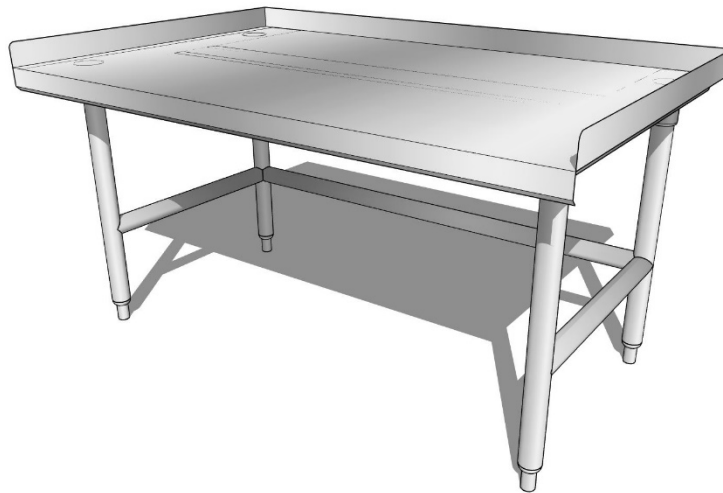

MODEL NUMBER SELECTION / INFORMATION

(Example #: 5ES-30-SLC)

Equipment stands are available in standard lengths from 2'-0" to 8'-0", in 1-foot increments. Standard widths (front-to-back) are available in 24" and 30". Units over 6'-0" long will be furnished with an additional set of legs.

- See **AutoQuotes™** for full list of model numbers and pricing, along with all additional accessories
- Custom sizes and configurations are available upon request

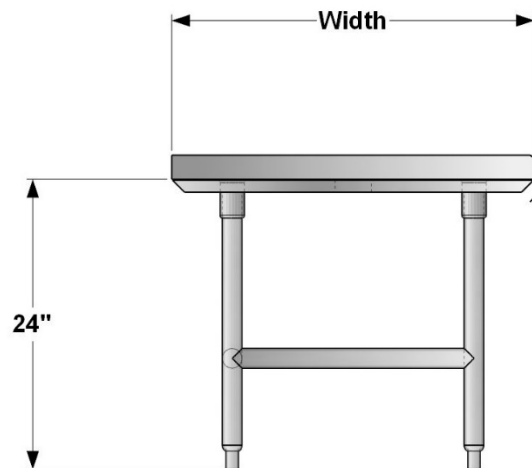
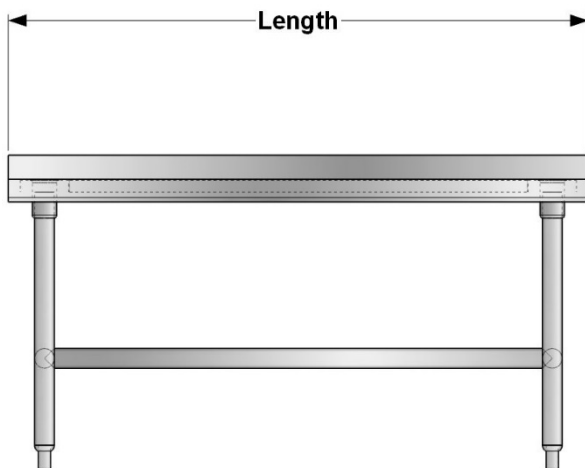

TITAN STAINLESS

502 Usher Street · PO Box 8 · Pageland, SC 29728
Contact: 704-243-8717 · quotes@titan-stainless.com · www.titan-stainless.com

