



The Legacy Companies
 3355 Enterprise Avenue, Suite 160, Fort Lauderdale, FL 33331
 Sales: (954) 202-7419 • Sales@TheLegacyCompanies.com

Project Name: _____
 Location: _____
 Item #: _____ Qty: _____
 Model: _____

XC-15-T

POTATO & VEGETABLE PEELER- FLOOR TYPE

This is highly important for the kitchen where time, work and food savings are a must. Peel 15lbs.(7kg) – 20lbs(9kg) of potatoes in 1-3 mins. Get perfectly peeled, washed hardcore vegetables ready for further preparation.

* The T in the model number indicates a TIMER is included with this model.

FEATURES

- Easy to clean
- Adjustable 5-minute timer
- Cast aluminum discharge chute
- Dual V-belt
- Motor and Drive unit sealed off against moisture to assure trouble free performance
- Discharge can be directly into sink



CAPACITY

- 15lbs(23kg) - 20lbs(9kg) in 1-3mins
- Serves 45-50 people per cycle when potatoes are mashed in Blakeslee Food Mixer

CONSTRUCTION & FINISH

- Stainless steel unit
- Easy to clean aluminum hinged door
- Light weight molded polystyrene removable cover

DISCHARGE CHUTE

- Rust-proof and easy-to-clean aluminum
- Hinged door, no gasket, for fingertips is all that is required to open and close door
- Trough is in the discharge chute to catch seepage returning it to the machine
- Trough and door without a gasket eliminates problems of a gasket wearing out and water seeping past the door
- Self-closing door when released from open position

MOTORS

- 1/3 HP
- 115-230V/ 60/1
- Greased packed, ball bearing ventilated motor
- Cord and plug included

TIMER

- Timer range from 0 to 5 mins

DRIVE

- Dual V-Belt drive provides speed reduction between motor and abrasive peeling disc for efficient peeling action
- Standard size V-belt for easy replacement
- Adjustment and replacing of belt without dismantling machine
- Stainless steel drive shaft
- Design and construction machine and seal system insures water-tight drive area

ABRASIVE DISC

- Rustproof cast aluminum abrasive peeling disc are included
- Abrasive carborundum is permanently cast into disc
- Light in weight for easy removal

Due to periodic changes in designs, methods, procedures, policies and regulations, the specifications contained in this sheet are subject to change without notice. While we exercise good faith efforts to provide information that is accurate, we are not responsible for errors or omissions in information provided or conclusions reached as a result of using the specifications. By using the information provided, the user assumes all risks in connection with such use.

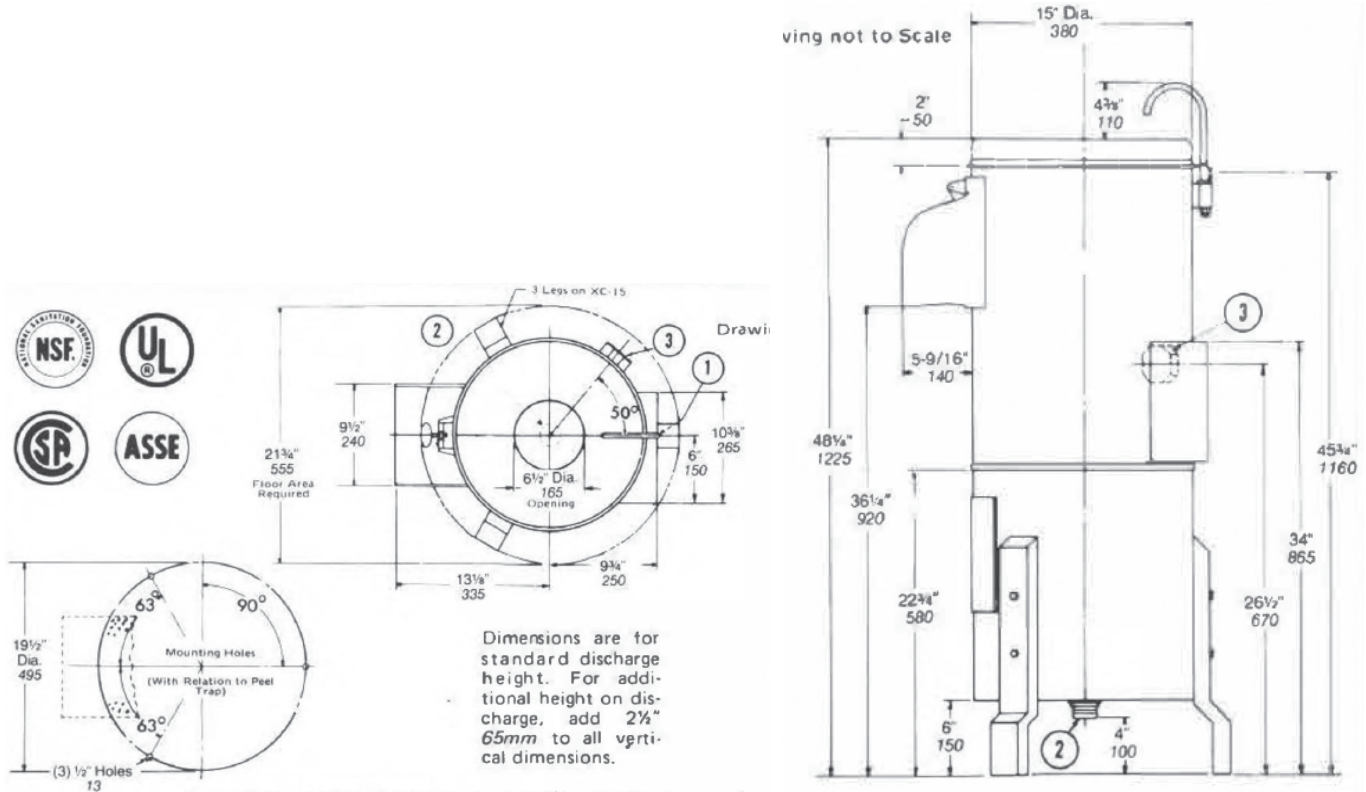
POTATO & VEGETABLE PEELER- FLOOR TYPE

NO.	CONNECTION	FITTING	FUNCTION
1	Cold Water	½ (13mm) Hose Fitting	Peel Flushing Spray
2	Waste-Sewer	2 (50mm) Drain Tubing	Cylinder Drain
3	Electrical	1/3 HP Motor	3-Wire -3" (76mm) Electrical Box

General Notes

Model XC-15T Furnished with 0-5 minute adjustable timer and a "hold" for continuous operation. (Single phase only)

APPROXIMATE SHIPPING SPECIFICATIONS

MODEL	Domestic Crated	Export Boxed	Export Cubed	Weight	Dimensions
XC-15-T	160lbs / 73kg	200lbs / 86kg	33.4ft / 0.95m ³	168lbs / 76kg	32"(813mm) x 29"(736mm) x 62"(1575mm)