

- **CO34R** 36-1/4"L x 33"D x 46-7/8"H
- **CO44R** 47-1/4"L x 33"D x 46-7/8"H

Included

- Breeze self-contained refrigeration
- 4"D removable rear wall spacer (not included in depth dimension)
- 6' Straight blade power cord (base exit)
- Blue Fin coated coil
- Condensate pan (self-contained refrig. only)
- Exterior solid back panel, black
- Full end panel w/mirror interior (vinyl edge matches interior color)
- Integrated average product temperature of 40°F or less
- LED 3500K top light(s)
- One piece formed ABS plastic tub
- One year parts & labor; 5 year compressor warranty



CO44R

Specify	Standard Features	Additional Options
EXTERIOR COLOR	• Laminate (stock colors)	• Laminate (non-stock colors) • Stainless steel
INTERIOR COLOR	• Powder coated Silversan Black	• Stainless steel
LOWER FRONT PANEL COLOR	• Powder coated Silversan Black	• Stainless steel (must choose stainless exterior)
BASE SUPPORT	• Casters w/ levelers (self-cont.)	• Levelers (only) • Seismic levelers
SHELVING	• None	• Metal shelf, non-lighted
ELECTRICAL CONNECTION	• 6' Straight blade power cord (self-cont.)	• 6' Locking power cord (self-cont.) • Electrical leads (remote)
REFRIGERATION	• Breeze self-contained refrigeration	• Note: Remote doesn't incl Conds unit. Floor drain reqd. • Remote w/thermostat, solenoid & TXV
MISCELLANEOUS		• Second year parts & labor warranty (excludes compressor)
ACCESSORIES		• 2"H Display risers for lower area (n/a w/shelf) • Clean Sweep® coil cleaner (self-cont.) • Night curtain, retractable, non-locking • Removable solid security cover, locking

Intended Environment: Type I - Designed to operate in ambient conditions of 75°F with 55% relative humidity unless noted otherwise in system information below.		
Zone	Intended Product To Be Displayed	Warmest Avg Prod Temp ° F
1	Packaged refrigerated products	40

PLAN VIEW

SIDE VIEW

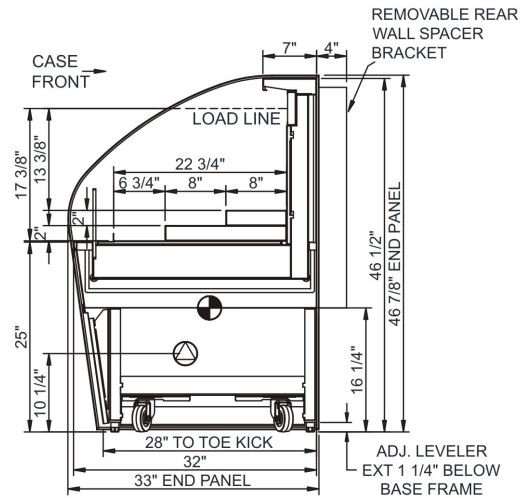
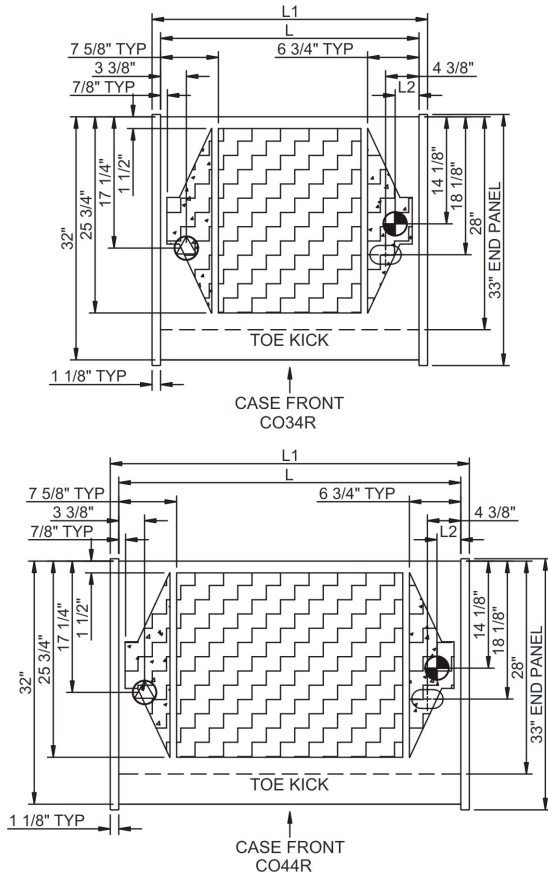

NOTE: ALL DIMENSIONS APPROXIMATE

- ELECTRICAL JUNCTION BOX (SUPPLIED WITH 6\"/>
- LOCATION OF DRAIN TUBE FOR REMOTE REF. ONLY (SUPPLIED WITH 3/4\"/>
- REFRIGERATION LINE CONNECTION.
- REMOTE FLOOR SINK & UTILITIES ACCESS AREA.
- SELF-CONTAINED CASE SERVICE ACCESS AREA.
- DRY CASE SERVICE ACCESS AREA.

Model Technical Specifications

Model	L"	L1"	L2"	System Circuit Volts		Phs	Freq	Amps ***	Watts	Wires	NEMA Plug	SST	Conv. Rack BTUH	Para. Rack BTUH	Est Wt	
				Remote (DX)	Self-Contained (R513A)											
CO34R	34.00	36.25	3.13	Remote (DX)	Circuit #1	110-120	1	60	0.74	48	2+G	Leads Multiple	20.00	1927	1784	600
				Self-Contained (R513A)	Circuit #1	110-120	1	60	5.80	311	N/A	5-15P or L5-15P	N/A	N/A	N/A	
CO44R	45.00	47.25	3.13	Remote (DX)	Circuit #1	110-120	1	60	0.86	56	2+G	Leads Multiple	20.00	2484	2300	650
				Self-Contained (R513A)	Circuit #1	110-120	1	60	5.80	311	2+G	5-20P or L5-20P	N/A	N/A	N/A	

*** Does not include electric defrost on freezer models.

Regulatory Approvals:

All Models
 Accordance with AHRI Std 1200
 ETL Listed to UL 471
 ETL Listed to CAN/CSA 22.2 No. 120
 ETL Sanitation to NSF/ANSI 7



Important Notes:

1) ELECTRICAL NOTE: If GFCI is required, a GFCI breaker MUST be used in lieu of a GFCI receptacle.

2) Compressor air front intake, rear discharge. Front panel cannot be blocked. Must remain 4" from wall.

⚠ WARNING: This product can expose you to chemicals, including Urethane (Ethyl Carbamate), which are known to the State of California to cause cancer and birth defects or other reproductive harm. For more information go to www.P65Warnings.ca.gov.