

KCTS

Mobile Tray and Silver Stands

KCTS: Mobile Tray and Silver Stands

MODELS

KCTS-28

KCTS-36

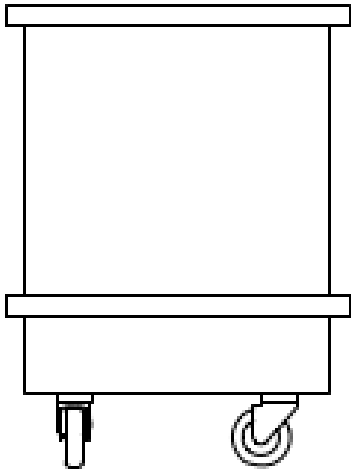

Optional Accessories & Modifications

- F)** Line-up interlock device
- ST)** Stainless steel trim strips
- SW)** Silverware cutouts with stainless steel bins
- SW6)** Six each silverware cutouts with stainless steel bins
- SW8)** Eight each silverware cutouts with stainless steel bins
- SW10)** Ten Silverware cutouts with stainless steel bins
- UU)** Molded fiberglass trim strips
- V)** 6" (15.2cm) high adjustable stainless steel legs in lieu of casters

Short Form Specifications

Exterior body is seamless, one-piece molded fiberglass, having perfectly smooth exterior surfaces and corners fully rounded. The fiberglass reinforced polyester (F.R.P.) is molded with permanent color. Stress points are internally reinforced.

Exterior top is constructed of 14-gauge stainless steel, welded, ground and polished into one integral unit. Top is fabricated with square exterior corners.

Casters unit is mounted on 5" (12.7cm) diameter swivel casters with non-marking polyolefin tires and plate brakes. Overall height of caster assembly is 6" (15.2cm).

Two year parts and labor warranty.



Mobile Tray and Silver stands

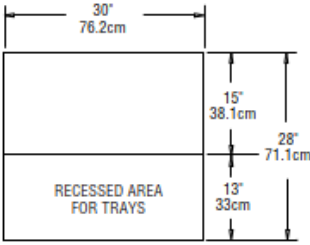

**PLAN VIEW
KCTS-28**

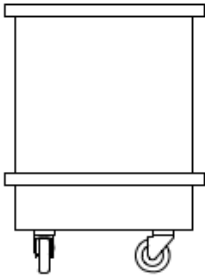

**ELEVATION VIEW
KCTS-28**

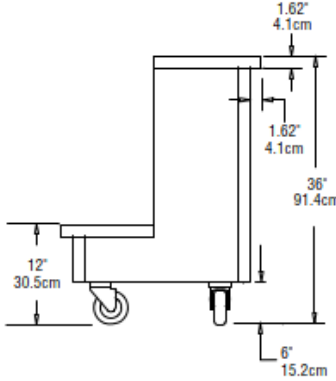

**END VIEW
KCTS-28**

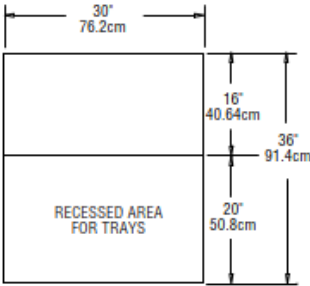

**PLAN VIEW
KCTS-36**

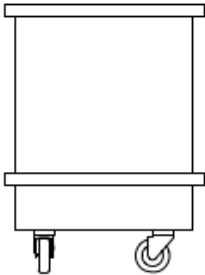

**ELEVATION VIEW
KCTS-36**

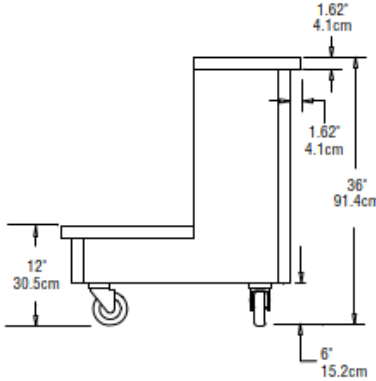

**END VIEW
KCTS-36**

Mechanical Data—Standard Unit

MODEL NUMBER	SHIP WEIGHT
KCTS-28	150 lbs/68 kg
KCTS-36	192 lbs/87kg

Delfield reserves the right to make changes to the design or specifications without prior notice.